

Investigating the Antiplatelet Effects of NQ301: A Technical Guide

Author: BenchChem Technical Support Team. **Date:** December 2025

Compound of Interest

Compound Name: NQ301

Cat. No.: B1680076

[Get Quote](#)

For Researchers, Scientists, and Drug Development Professionals

Abstract

NQ301, chemically identified as 2-chloro-3-(4-acetophenyl)-amino-1,4-naphthoquinone, is a synthetic naphthoquinone derivative that has demonstrated significant antiplatelet and antithrombotic properties in preclinical studies. This technical guide provides a comprehensive overview of the current understanding of **NQ301**'s mechanism of action, supported by quantitative data from in vitro and in vivo experiments. The document details the experimental methodologies employed in key studies, presents data in a structured format for comparative analysis, and visualizes the compound's signaling pathways and experimental workflows. The evidence suggests that **NQ301** exerts its effects primarily through the inhibition of intracellular calcium mobilization and the thromboxane A2 (TXA2) signaling cascade, without significantly impacting blood coagulation pathways. This profile positions **NQ301** as a promising candidate for further investigation as a novel antithrombotic agent.

Introduction

Thrombotic diseases, including myocardial infarction and stroke, are leading causes of morbidity and mortality worldwide. Antiplatelet therapy is a cornerstone of prevention and treatment for these conditions. **NQ301** has emerged as a potent inhibitor of platelet aggregation in preclinical models. This guide synthesizes the available scientific literature to provide an in-depth technical resource for professionals involved in thrombosis research and drug development.

Quantitative Data on the Antiplatelet Effects of NQ301

The inhibitory activity of **NQ301** on platelet aggregation has been quantified against various agonists in both human and rabbit platelets. The following tables summarize the reported half-maximal inhibitory concentrations (IC50).

Table 1: In Vitro Inhibition of Human Platelet Aggregation by **NQ301**[1]

Agonist	IC50 (μM)
Collagen	13.0 ± 0.1
Thrombin	11.2 ± 0.5
Arachidonic Acid	21.0 ± 0.9
Thapsigargin	3.8 ± 0.1
Calcium Ionophore A23187	46.2 ± 0.8

Table 2: In Vitro Inhibition of Rabbit Platelet Aggregation by **NQ301**[2]

Agonist	Agonist Concentration	IC50 (μM)
Collagen	10 μg/ml	0.60 ± 0.02
Arachidonic Acid	100 μM	0.78 ± 0.04
U46619 (TXA2 mimetic)	1 μM	0.58 ± 0.04

Table 3: In Vivo and Ex Vivo Effects of **NQ301**[3]

Experimental Model	Effect
Murine Pulmonary Thrombosis (in vivo)	Dose-dependent prevention of death
Rat Platelet Aggregation (ex vivo, oral administration)	Significant inhibition
Mouse Tail Bleeding Time (in vivo)	Significant prolongation

Mechanism of Action: Signaling Pathways

NQ301's antiplatelet effects are attributed to its modulation of key intracellular signaling pathways that govern platelet activation. The primary mechanisms identified are the inhibition of intracellular calcium mobilization and the interference with the thromboxane A2 (TXA2) pathway.

Inhibition of Intracellular Calcium Mobilization

Platelet activation is critically dependent on an increase in cytosolic free calcium ($[Ca^{2+}]_i$). **NQ301** has been shown to significantly inhibit the rise in $[Ca^{2+}]_i$ induced by various agonists^[1]. This inhibitory action disrupts downstream signaling events that lead to platelet shape change, granule secretion, and aggregation.

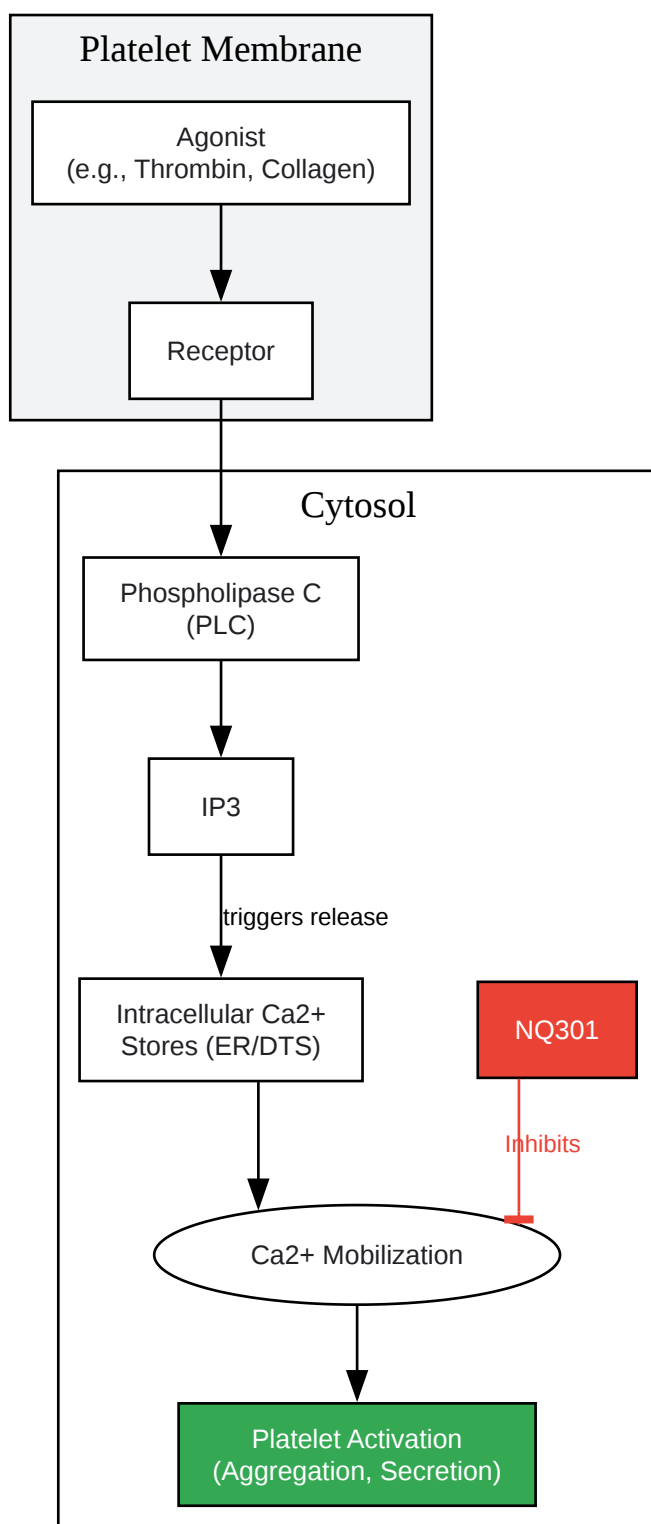

[Click to download full resolution via product page](#)

*Inhibition of Calcium Mobilization by **NQ301**.*

Interference with the Thromboxane A2 Pathway

NQ301 demonstrates a dual effect on the arachidonic acid cascade. It acts as a competitive antagonist of the thromboxane A2/prostaglandin H2 (TXA2/PGH2) receptor and also inhibits thromboxane A2 synthase, the enzyme responsible for TXA2 production[2]. This comprehensive blockade of the TXA2 pathway significantly curtails platelet aggregation and vasoconstriction.

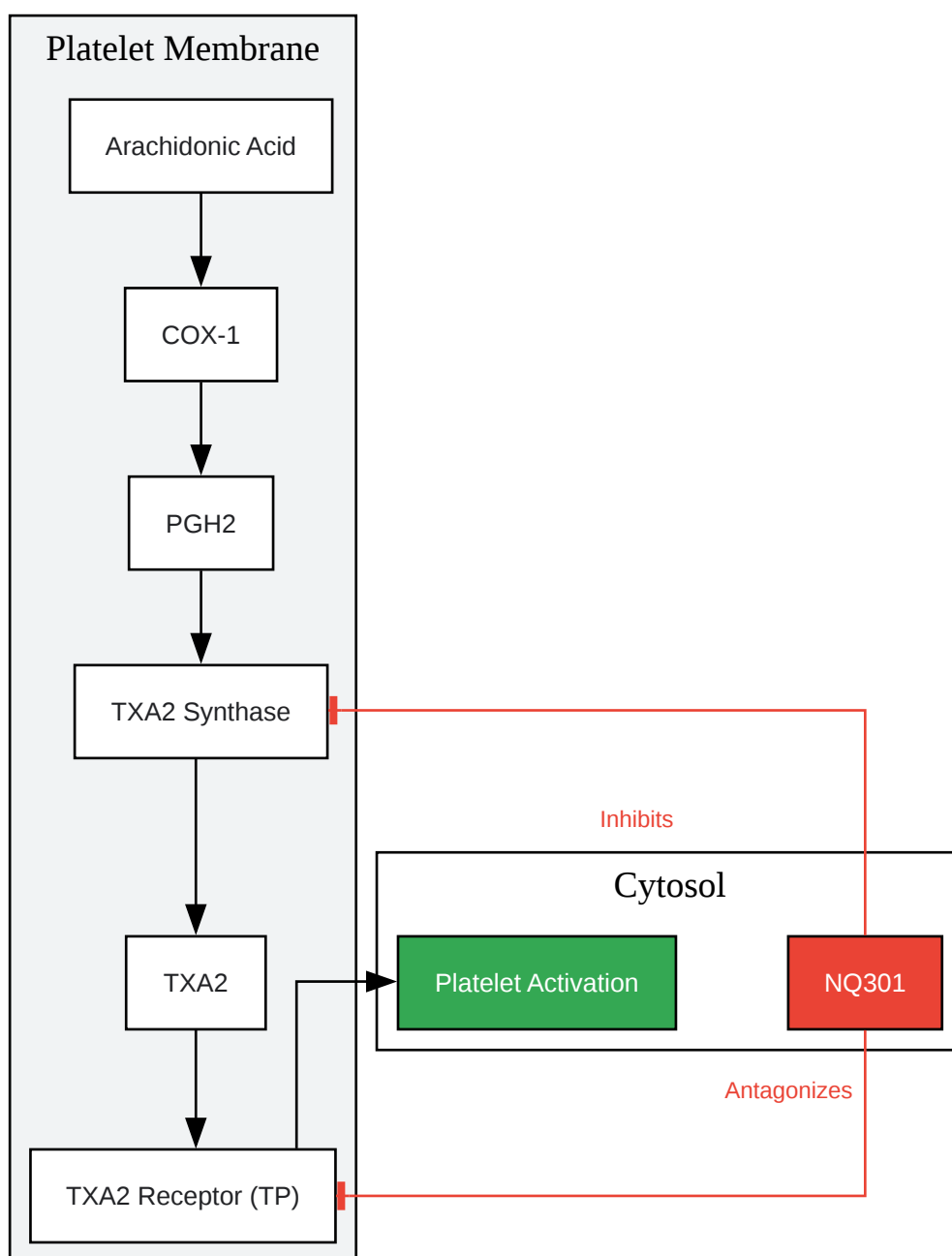

[Click to download full resolution via product page](#)

*Dual Inhibition of the Thromboxane A2 Pathway by **NQ301**.*

Experimental Protocols

Disclaimer: The following experimental protocols are summarized based on the methodologies described in the abstracts of the cited research articles. Detailed, step-by-step protocols from the full-text publications were not accessible.

In Vitro Platelet Aggregation Assay

This assay measures the extent of platelet aggregation in response to various agonists.

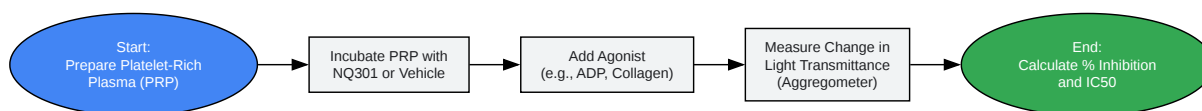

[Click to download full resolution via product page](#)

Workflow for In Vitro Platelet Aggregation Assay.

Methodology:

- **Platelet-Rich Plasma (PRP) Preparation:** Whole blood is collected from healthy human donors or rabbits into tubes containing an anticoagulant (e.g., sodium citrate). The blood is then centrifuged at a low speed to separate the PRP.
- **Incubation:** PRP is incubated with varying concentrations of **NQ301** or a vehicle control for a specified period at 37°C.
- **Induction of Aggregation:** A platelet agonist (e.g., ADP, collagen, thrombin, arachidonic acid) is added to the PRP to induce aggregation.
- **Measurement:** Platelet aggregation is monitored by measuring the change in light transmittance through the PRP suspension using a platelet aggregometer. As platelets aggregate, the turbidity of the sample decreases, allowing more light to pass through.

- **Data Analysis:** The percentage of platelet aggregation is calculated, and the IC50 value for **NQ301** is determined.

Measurement of Cytosolic Calcium ([Ca²⁺]_i)

This assay quantifies changes in the concentration of free calcium within the platelets.

Methodology:

- **Platelet Loading:** Washed platelets are loaded with a fluorescent Ca²⁺ indicator dye (e.g., Fura-2/AM).
- **Incubation:** The dye-loaded platelets are incubated with different concentrations of **NQ301** or a vehicle control.
- **Stimulation:** A platelet agonist is added to stimulate an increase in intracellular calcium.
- **Fluorescence Measurement:** The change in fluorescence of the Ca²⁺ indicator is measured using a spectrofluorometer. The ratio of fluorescence at different excitation or emission wavelengths is used to calculate the intracellular calcium concentration.

Thromboxane A2 (TXA2) Synthase Activity Assay

This assay determines the effect of **NQ301** on the enzyme that produces TXA2.

Methodology:

- **Platelet Lysate Preparation:** Platelets are lysed to release their intracellular contents, including TXA2 synthase.
- **Incubation:** The platelet lysate is incubated with **NQ301** at various concentrations.
- **Enzymatic Reaction:** The substrate for TXA2 synthase, prostaglandin H2 (PGH2), is added to the lysate.
- **Product Measurement:** The reaction is stopped, and the amount of thromboxane B2 (TXB2), the stable metabolite of TXA2, is quantified using a specific immunoassay (e.g., ELISA).

In Vivo and Ex Vivo Studies

Preclinical studies in animal models have provided further evidence for the antithrombotic potential of **NQ301**.

- **Murine Pulmonary Thrombosis Model:** In a mouse model of thrombosis, **NQ301** administered in a dose-dependent manner was able to prevent death, indicating its potent antithrombotic effect in vivo.
- **Rat Ex Vivo Platelet Aggregation:** When administered orally to rats, **NQ301** significantly inhibited platelet aggregation in blood samples taken from the animals, demonstrating its oral bioavailability and efficacy.
- **Bleeding Time:** **NQ301** was found to significantly prolong tail bleeding time in mice, an expected outcome for an effective antiplatelet agent.

Effects on Coagulation

An important characteristic of a safe antiplatelet agent is the absence of a significant impact on the coagulation cascade, which could otherwise lead to systemic bleeding complications. Studies have shown that **NQ301** does not alter key coagulation parameters, including activated partial thromboplastin time (aPTT), prothrombin time (PT), and thrombin time (TT) in human plasma. This suggests that the antithrombotic activity of **NQ301** is due to its antiplatelet effects and not to an anticoagulant mechanism.

Clinical Development Status

As of the latest available information, there are no publicly registered clinical trials for **NQ301**. The compound appears to be in the preclinical stage of development.

Conclusion

NQ301 is a promising preclinical antiplatelet agent with a well-defined mechanism of action centered on the inhibition of intracellular calcium signaling and the thromboxane A2 pathway. Its efficacy in in vitro and in vivo models, coupled with a lack of interference with the coagulation cascade, highlights its potential as a novel antithrombotic drug. Further research, including detailed pharmacokinetic and pharmacodynamic studies, and eventually, well-

designed clinical trials, will be necessary to fully elucidate the therapeutic potential and safety profile of **NQ301** in humans.

Need Custom Synthesis?

BenchChem offers custom synthesis for rare earth carbides and specific isotopic labeling.

Email: info@benchchem.com or [Request Quote Online](#).

References

- 1. Antiplatelet effect of 2-chloro-3-(4-acetophenyl)-amino-1,4-naphthoquinone (NQ301): a possible mechanism through inhibition of intracellular Ca²⁺ mobilization - PubMed [pubmed.ncbi.nlm.nih.gov]
- 2. An antithrombotic agent, NQ301, inhibits thromboxane A₂ receptor and synthase activity in rabbit platelets - PubMed [pubmed.ncbi.nlm.nih.gov]
- 3. Antiplatelet and antithrombotic activities of NQ301, 2-chloro-3-(4-acetophenyl)-amino-1,4-naphthoquinone - PubMed [pubmed.ncbi.nlm.nih.gov]
- To cite this document: BenchChem. [Investigating the Antiplatelet Effects of NQ301: A Technical Guide]. BenchChem, [2025]. [Online PDF]. Available at: [https://www.benchchem.com/product/b1680076#investigating-the-antiplatelet-effects-of-nq301]

Disclaimer & Data Validity:

The information provided in this document is for Research Use Only (RUO) and is strictly not intended for diagnostic or therapeutic procedures. While BenchChem strives to provide accurate protocols, we make no warranties, express or implied, regarding the fitness of this product for every specific experimental setup.

Technical Support: The protocols provided are for reference purposes. Unsure if this reagent suits your experiment? [[Contact our Ph.D. Support Team for a compatibility check](#)]

Need Industrial/Bulk Grade? [Request Custom Synthesis Quote](#)

BenchChem

Our mission is to be the trusted global source of essential and advanced chemicals, empowering scientists and researchers to drive progress in science and industry.

Contact

Address: 3281 E Guasti Rd

Ontario, CA 91761, United States

Phone: (601) 213-4426

Email: info@benchchem.com