

# Interpreting unexpected results in (R)-DRF053 dihydrochloride experiments

**Author:** BenchChem Technical Support Team. **Date:** December 2025

## Compound of Interest

Compound Name: (R)-DRF053 dihydrochloride

Cat. No.: B10768303

[Get Quote](#)

## Technical Support Center: (R)-DRF053 Dihydrochloride Experiments

Welcome to the technical support center for **(R)-DRF053 dihydrochloride**. This resource is designed for researchers, scientists, and drug development professionals to provide guidance on interpreting unexpected results and to offer detailed experimental protocols.

### Frequently Asked Questions (FAQs)

Q1: What is **(R)-DRF053 dihydrochloride** and what is its primary mechanism of action?

**(R)-DRF053 dihydrochloride** is a potent, ATP-competitive inhibitor of Casein Kinase 1 (CK1) and several Cyclin-Dependent Kinases (CDKs).<sup>[1][2][3][4]</sup> It has been shown to inhibit CDK1/cyclin B, CDK5/p25, and CK1 with high potency.<sup>[1][2]</sup> The compound is also known to inhibit the production of amyloid-beta in cellular models.<sup>[1][2][3][4]</sup>

Q2: What are the recommended solvent and storage conditions for **(R)-DRF053 dihydrochloride**?

**(R)-DRF053 dihydrochloride** is soluble in water and DMSO up to 100 mM.<sup>[1][3][4]</sup> For short-term storage, +4°C is recommended.<sup>[1][3][4]</sup> For long-term storage of stock solutions, it is advisable to aliquot and store at -20°C for up to one month or -80°C for up to six months to avoid repeated freeze-thaw cycles.<sup>[2]</sup>

Q3: At what concentrations should I expect to see biological activity?

The in vitro inhibitory concentrations (IC50) are in the nanomolar to low micromolar range for its primary targets. See the data summary table below for specific values. For cell-based assays, the effective concentration will depend on the cell type and experimental conditions, but starting with a concentration range around the IC50 values is recommended.

## Data Presentation: Inhibitory Activity of (R)-DRF053

Target Kinase	IC50 Value
Casein Kinase 1 (CK1)	14 nM[1][2][3][4]
CDK5/p25	80 nM[1][2]
CDK1/cyclin B	220 nM[1][2]
CDK2	93 - 290 nM[3][4]
CDK7	820 nM[3][4]
GSK $\alpha/\beta$	4.1 $\mu$ M[1]

## Troubleshooting Unexpected Results

This section addresses potential issues you might encounter during your experiments with **(R)-DRF053 dihydrochloride**.

### Issue 1: No or Lower Than Expected Inhibition of Target Kinase Activity

Possible Causes & Troubleshooting Steps:

- Incorrect Compound Concentration:
  - Verify Calculations: Double-check all calculations for preparing stock solutions and working dilutions.
  - Fresh Dilutions: Prepare fresh dilutions from your stock solution for each experiment.

- Compound Degradation:
  - Storage: Ensure the compound has been stored correctly at +4°C for solid form and -20°C or -80°C for stock solutions.[1][2] Avoid multiple freeze-thaw cycles.[2]
  - Purity: If possible, verify the purity of the compound using a suitable analytical method like HPLC.
- Assay Conditions:
  - ATP Concentration: As an ATP-competitive inhibitor, the apparent IC<sub>50</sub> value will be influenced by the ATP concentration in your assay. Ensure your ATP concentration is at or below the K<sub>m</sub> for the kinase.
  - Enzyme Activity: Confirm the activity of your kinase enzyme with a known control inhibitor.

## Issue 2: High Cell Toxicity or Unexpected Off-Target Effects

### Possible Causes & Troubleshooting Steps:

- Solvent Toxicity:
  - Vehicle Control: Always include a vehicle control (e.g., DMSO or water at the same final concentration) to distinguish between compound and solvent effects.
- High Compound Concentration:
  - Dose-Response Curve: Perform a dose-response experiment to determine the optimal, non-toxic concentration range for your specific cell line.
- Off-Target Kinase Inhibition:
  - Selectivity Profiling: (R)-DRF053 inhibits multiple kinases. Consider that the observed phenotype might be due to the inhibition of a combination of CDKs and CK1.
  - Rescue Experiments: If you hypothesize an off-target effect, try to rescue the phenotype by overexpressing the suspected off-target protein.

## Experimental Protocols

### Kinase Inhibition Assay (Generic Protocol)

- Prepare Reagents:
  - Kinase buffer (specific to the kinase of interest).
  - Kinase enzyme.
  - Substrate (peptide or protein).
  - ATP (at or below  $K_m$  concentration).
  - **(R)-DRF053 dihydrochloride** serial dilutions.
  - Detection reagent (e.g., ADP-Glo™ Kinase Assay).
- Assay Procedure:
  - Add 5  $\mu\text{L}$  of kinase buffer to all wells of a 96-well plate.
  - Add 2.5  $\mu\text{L}$  of the test compound at various concentrations.
  - Add 2.5  $\mu\text{L}$  of the kinase/substrate mixture.
  - Incubate for 10 minutes at room temperature.
  - Initiate the reaction by adding 5  $\mu\text{L}$  of ATP solution.
  - Incubate for the recommended time for the specific kinase (e.g., 60 minutes at 30°C).
  - Stop the reaction and measure the signal according to the detection reagent's protocol.
- Data Analysis:
  - Calculate the percentage of inhibition for each concentration relative to the vehicle control.
  - Plot the percentage of inhibition against the compound concentration and fit the data to a suitable model to determine the  $\text{IC}_{50}$  value.

## Cell Viability (MTT) Assay

- Cell Seeding: Seed cells in a 96-well plate at a density of 5,000-10,000 cells per well and allow them to adhere overnight.
- Compound Treatment:
  - Prepare serial dilutions of **(R)-DRF053 dihydrochloride** in the appropriate cell culture medium.
  - Replace the existing medium with the medium containing the compound dilutions. Include a vehicle control.
- Incubation: Incubate the cells for the desired duration (e.g., 24, 48, or 72 hours).
- MTT Addition: Add 20  $\mu\text{L}$  of 5 mg/mL MTT solution to each well and incubate for 4 hours at 37°C.
- Formazan Solubilization: Remove the medium and add 150  $\mu\text{L}$  of DMSO to each well to dissolve the formazan crystals.
- Absorbance Measurement: Measure the absorbance at 570 nm.
- Data Analysis: Calculate cell viability as a percentage of the vehicle-treated control.

## Visualizations

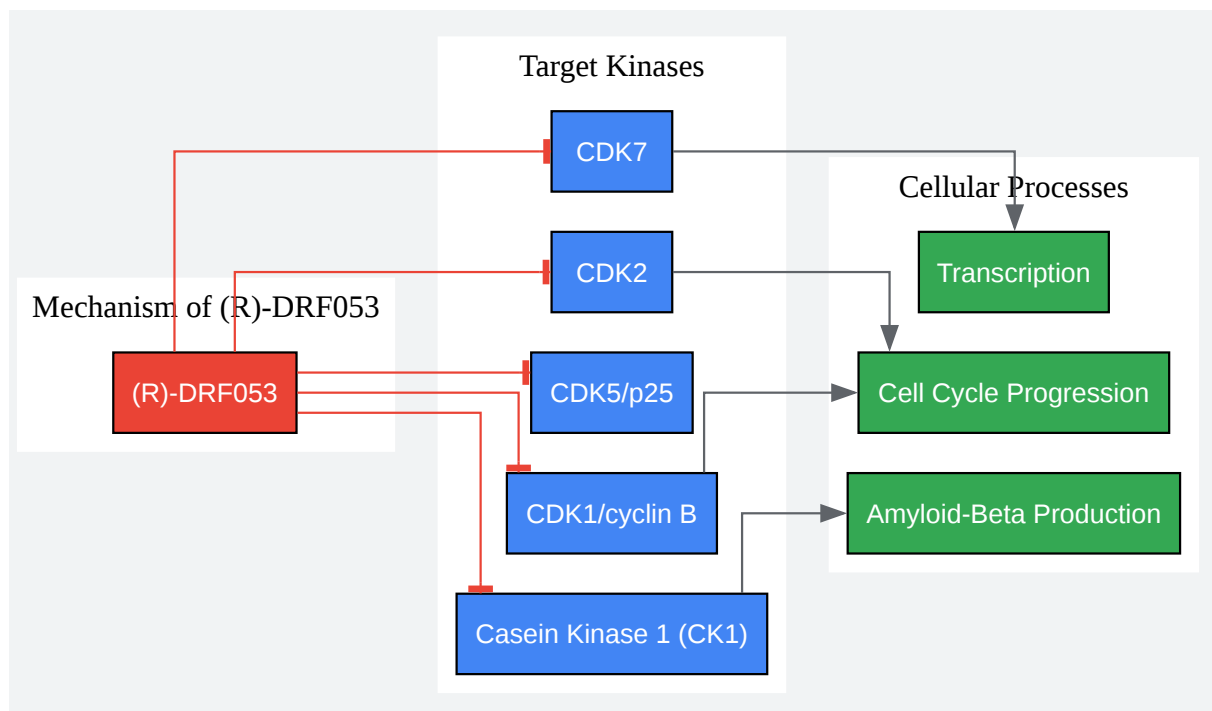

[Click to download full resolution via product page](#)

Caption: Inhibition of target kinases and downstream cellular processes by (R)-DRF053.

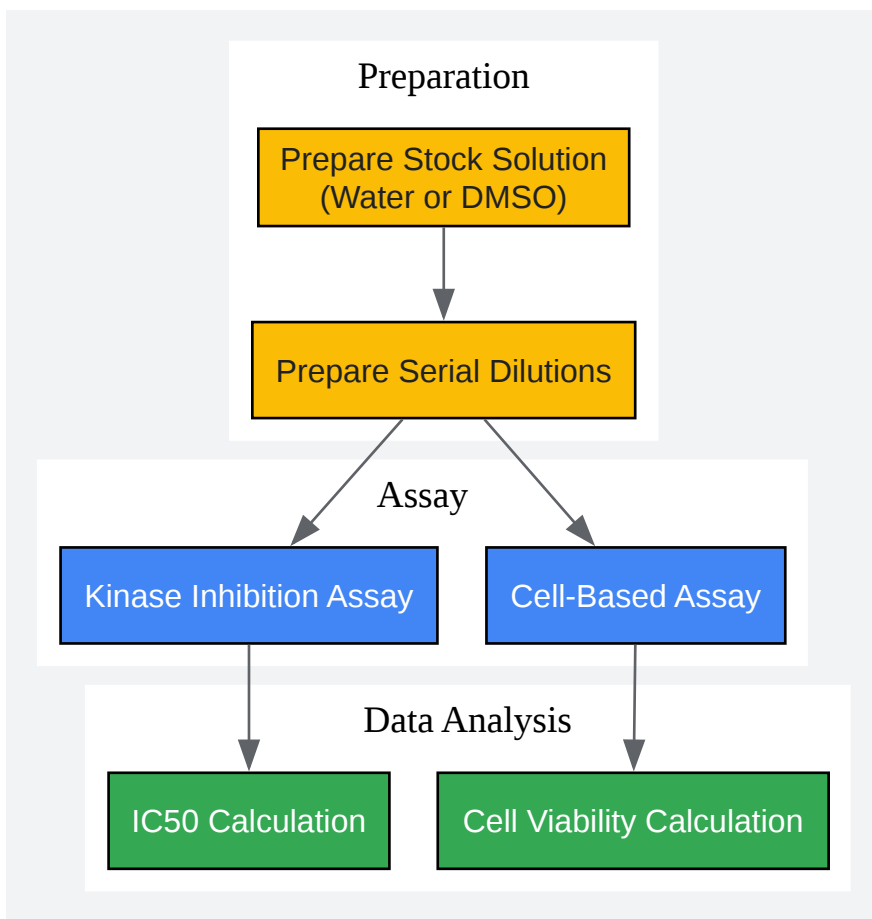

[Click to download full resolution via product page](#)

Caption: General experimental workflow for using **(R)-DRF053 dihydrochloride**.

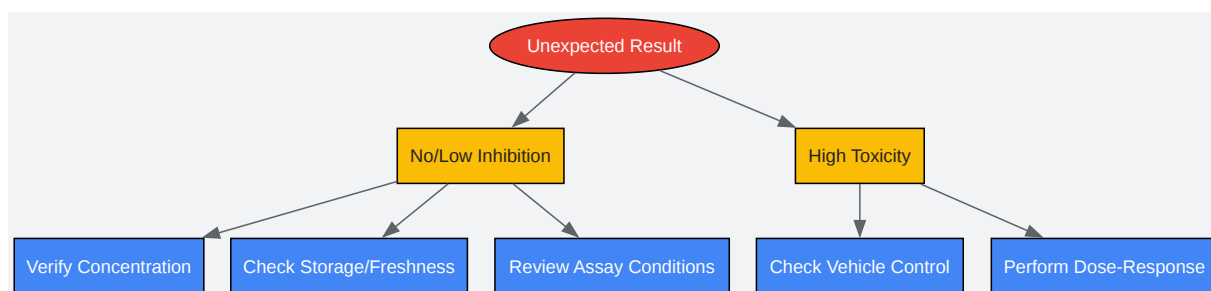

[Click to download full resolution via product page](#)

Caption: Troubleshooting logic for unexpected results in (R)-DRF053 experiments.

### Need Custom Synthesis?

BenchChem offers custom synthesis for rare earth carbides and specific isotopic labeling.

Email: [info@benchchem.com](mailto:info@benchchem.com) or [Request Quote Online](#).

## References

- 1. (R)-DRF053 dihydrochloride, CDK and CK1 inhibitor (CAS 1241675-76-2) | Abcam [abcam.com]
- 2. medchemexpress.com [medchemexpress.com]
- 3. (R)-DRF053 dihydrochloride | Casein Kinase 1 | Tocris Bioscience [toocris.com]
- 4. (R)-DRF053 dihydrochloride | Casein Kinase 1 | Tocris Bioscience [toocris.com]
- To cite this document: BenchChem. [Interpreting unexpected results in (R)-DRF053 dihydrochloride experiments]. BenchChem, [2025]. [Online PDF]. Available at: [https://www.benchchem.com/product/b10768303#interpreting-unexpected-results-in-r-drf053-dihydrochloride-experiments]

---

### Disclaimer & Data Validity:

The information provided in this document is for Research Use Only (RUO) and is strictly not intended for diagnostic or therapeutic procedures. While BenchChem strives to provide accurate protocols, we make no warranties, express or implied, regarding the fitness of this product for every specific experimental setup.

**Technical Support:** The protocols provided are for reference purposes. Unsure if this reagent suits your experiment? [[Contact our Ph.D. Support Team for a compatibility check](#)]

**Need Industrial/Bulk Grade?** [Request Custom Synthesis Quote](#)



# BenchChem

Our mission is to be the trusted global source of essential and advanced chemicals, empowering scientists and researchers to drive progress in science and industry.

## Contact

Address: 3281 E Guasti Rd

Ontario, CA 91761, United States

Phone: (601) 213-4426

Email: [info@benchchem.com](mailto:info@benchchem.com)