

Interpreting unexpected results from XY221 experiments

Author: BenchChem Technical Support Team. **Date:** December 2025

Compound of Interest

Compound Name: XY221

Cat. No.: B15604862

[Get Quote](#)

Technical Support Center: XY221 Experiments

This technical support center provides troubleshooting guidance and answers to frequently asked questions for researchers, scientists, and drug development professionals working with **XY221**, a selective mTORC1 inhibitor.

Troubleshooting Guides

This section addresses specific unexpected results you may encounter during your experiments with **XY221**. Each issue is presented in a question-and-answer format.

Q1: Why am I observing incomplete or differential inhibition of mTORC1 downstream targets? For instance, phosphorylation of p70S6K is inhibited, but 4E-BP1 phosphorylation is not.

A1: This is a frequently observed phenomenon when using mTORC1 inhibitors.^[1] Several factors can contribute to this differential regulation:

- Dose-Dependent Effects: Higher concentrations of mTORC1 inhibitors are often required to fully inhibit the phosphorylation of 4E-BP1 compared to p70S6K.^[1]

- Cellular Context and Feedback Loops: The mTOR signaling network is complex, with numerous feedback loops.[2][3][4][5] Inhibition of mTORC1 can sometimes lead to the activation of other signaling pathways, such as the PI3K/Akt pathway, which can independently influence 4E-BP1.[1][4]
- Temporal Dynamics: The kinetics of dephosphorylation for different substrates can vary. It is advisable to perform a time-course experiment to determine the optimal treatment duration.

Troubleshooting Steps:

- Optimize **XY221** Concentration: Perform a dose-response experiment to determine the IC50 for the inhibition of both p-p70S6K (Thr389) and p-4E-BP1 (Thr37/46).
- Conduct a Time-Course Experiment: Assess the phosphorylation status of downstream targets at various time points (e.g., 2, 6, 12, and 24 hours) after **XY221** treatment.
- Verify Pathway Specificity: Use appropriate controls, such as a known mTORC1/mTORC2 inhibitor, to confirm that the observed effects are specific to mTORC1 inhibition.[6]

Hypothetical Data Summary: Dose-Response of **XY221** in MCF-7 Cells (24h Treatment)

XY221 Conc. (nM)	% Inhibition of p-p70S6K (Thr389)	% Inhibition of p-4E-BP1 (Thr37/46)
1	55%	15%
10	92%	45%
100	98%	85%
1000	99%	95%

Diagram: mTORC1 Signaling and **XY221** Inhibition

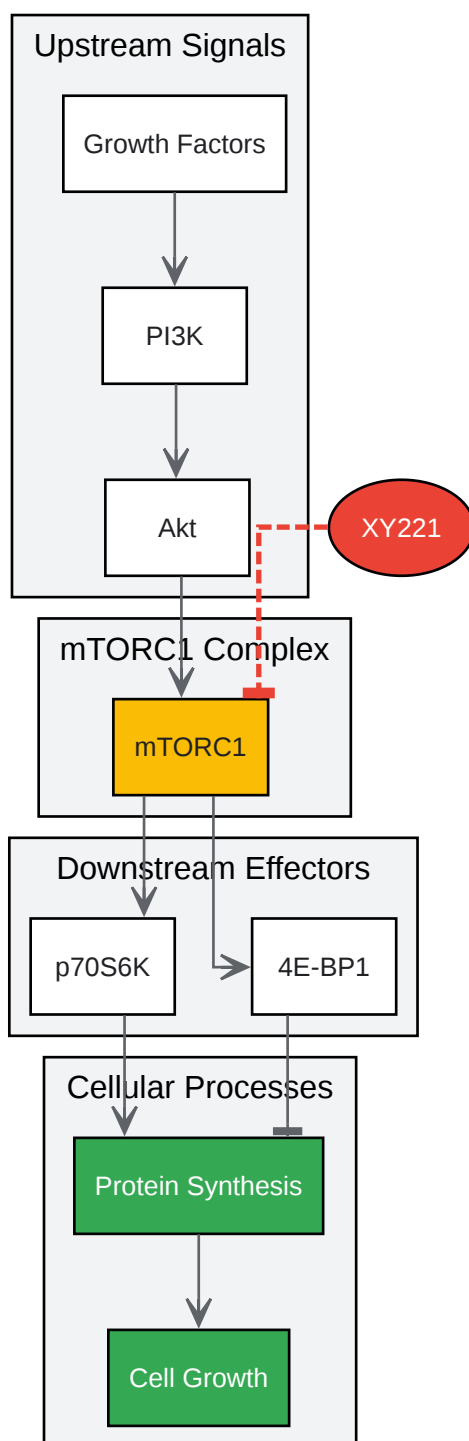

[Click to download full resolution via product page](#)

Caption: Simplified mTORC1 signaling pathway showing the inhibitory action of **XY221**.

Q2: Why is XY221 showing lower-than-expected efficacy in reducing cell viability in my cancer cell line?

A2: Reduced sensitivity to mTORC1 inhibitors like **XY221** can be attributed to several resistance mechanisms:

- **Activation of Feedback Loops:** A well-documented mechanism of resistance is the activation of pro-survival signaling pathways following mTORC1 inhibition.[4] Specifically, blocking the mTORC1/S6K1 axis can relieve a negative feedback loop, leading to the activation of PI3K/Akt signaling, which promotes cell survival.[1][2][5]
- **Compensatory Pathways:** Cancer cells can adapt to mTORC1 inhibition by upregulating parallel signaling pathways, such as the MAPK/ERK pathway, to maintain proliferation and survival.[4]
- **Cell Line-Specific Dependencies:** The genetic background of the cell line plays a crucial role. Cells that are not highly dependent on the mTORC1 pathway for survival will show less sensitivity to its inhibition.

Troubleshooting Steps:

- **Assess Feedback Activation:** Following **XY221** treatment, perform a Western blot to check for an increase in the phosphorylation of Akt (at both Ser473 and Thr308) and ERK (p-ERK). An increase in these markers suggests the activation of compensatory pathways.[1]
- **Consider Combination Therapy:** If feedback activation is observed, consider combining **XY221** with a PI3K/Akt inhibitor or a MEK/ERK inhibitor to overcome resistance.
- **Profile Your Cell Line:** If possible, analyze the baseline activation of key survival pathways in your cell line to understand its signaling dependencies.

Hypothetical Data Summary: Cell Viability (MTT Assay) and Feedback Activation in PANC-1 Cells

Treatment	% Cell Viability (72h)	Fold Change in p-Akt (Ser473)
Vehicle Control	100%	1.0
XY221 (100 nM)	75%	3.5
PI3K Inhibitor (1 μ M)	60%	0.2
XY221 + PI3K Inhibitor	25%	0.3

Diagram: Troubleshooting Low Cell Viability Efficacy

Caption: Logical workflow for troubleshooting reduced efficacy of **XY221** on cell viability.

Key Experimental Protocols

Protocol: Western Blotting for Phosphorylated Proteins

This protocol is optimized for the detection of phosphorylated mTOR pathway proteins following **XY221** treatment.

- Cell Lysis:
 - Culture and treat cells with **XY221** at the desired concentrations and time points.
 - Wash cells twice with ice-cold PBS.
 - Lyse cells in RIPA buffer supplemented with a fresh cocktail of protease and phosphatase inhibitors.^{[7][8]} Keep samples on ice at all times to prevent dephosphorylation.^{[7][8]}
- Protein Quantification:
 - Determine the protein concentration of each lysate using a BCA assay.
- Sample Preparation:
 - Normalize protein concentrations for all samples.
 - Add Laemmli sample buffer and boil at 95°C for 5 minutes to denature the proteins.^{[7][9]}

- SDS-PAGE and Protein Transfer:
 - Separate 20-30 µg of protein per lane on an SDS-polyacrylamide gel.
 - Transfer the separated proteins to a PVDF membrane.[7]
- Blocking and Antibody Incubation:
 - Block the membrane for 1 hour at room temperature with 5% Bovine Serum Albumin (BSA) in Tris-Buffered Saline with 0.1% Tween-20 (TBST).[7][9] Note: Do not use milk for blocking, as it contains phosphoproteins that can cause high background.[8]
 - Incubate the membrane with a primary antibody specific to the phosphorylated protein of interest (e.g., anti-phospho-p70S6K) overnight at 4°C with gentle agitation.[7]
 - Wash the membrane three times with TBST for 10 minutes each.
 - Incubate with an appropriate HRP-conjugated secondary antibody for 1 hour at room temperature.
- Detection:
 - Wash the membrane three times with TBST for 10 minutes each.
 - Apply an enhanced chemiluminescence (ECL) substrate and visualize the bands using a digital imager.[9]
- Stripping and Re-probing:
 - To assess total protein levels, the membrane can be stripped and re-probed with an antibody against the total, non-phosphorylated protein (e.g., anti-total-p70S6K) and a loading control (e.g., GAPDH or β-actin).

Diagram: Western Blot Experimental Workflow

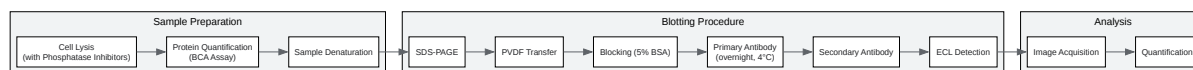

[Click to download full resolution via product page](#)

Caption: Standard experimental workflow for Western blotting of phosphorylated proteins.

Frequently Asked Questions (FAQs)

- Q: What is the recommended solvent for **XY221**?
 - A: **XY221** is highly soluble in DMSO (e.g., ≥ 50 mg/mL) and ethanol. For cell culture experiments, prepare a concentrated stock solution in DMSO and dilute it to the final working concentration in your culture medium. Ensure the final DMSO concentration does not exceed 0.1% to avoid solvent-induced toxicity.
- Q: How should I store **XY221**?
 - A: Store the solid compound at -20°C , protected from light and moisture. Stock solutions in DMSO can be stored in aliquots at -20°C or -80°C to minimize freeze-thaw cycles.
- Q: What is the stability of **XY221** in solution?
 - A: When stored properly at -20°C or below, DMSO stock solutions are stable for several months. Avoid repeated freeze-thaw cycles. For aqueous working solutions, it is recommended to prepare them fresh for each experiment.
- Q: Can **XY221** be used for in vivo experiments?
 - A: Yes, **XY221** has been formulated for in vivo use. Please refer to the specific product datasheet for recommended vehicles and dosing guidelines for animal studies.
- Q: Are there any known off-target effects of **XY221**?

- A: **XY221** is a highly selective inhibitor of mTORC1. However, at very high concentrations or with prolonged treatment, inhibition of mTORC2 assembly has been observed in some cell types.^[10] It is always recommended to use the lowest effective concentration and include appropriate controls to verify on-target effects.^[11]

Need Custom Synthesis?

BenchChem offers custom synthesis for rare earth carbides and specific isotopic labeling.

Email: info@benchchem.com or [Request Quote Online](#).

References

- 1. benchchem.com [benchchem.com]
- 2. mTOR and cancer: many loops in one pathway - PMC [pmc.ncbi.nlm.nih.gov]
- 3. researchgate.net [researchgate.net]
- 4. Suppression of feedback loops mediated by PI3K/mTOR induces multiple over-activation of compensatory pathways: an unintended consequence leading to drug resistance - PMC [pmc.ncbi.nlm.nih.gov]
- 5. mTOR signaling in growth control and disease - PMC [pmc.ncbi.nlm.nih.gov]
- 6. mdpi.com [mdpi.com]
- 7. researchgate.net [researchgate.net]
- 8. inventbiotech.com [inventbiotech.com]
- 9. Western blot for phosphorylated proteins | Abcam [abcam.com]
- 10. Next Generation Strategies for Geroprotection via mTORC1 Inhibition - PMC [pmc.ncbi.nlm.nih.gov]
- 11. researchgate.net [researchgate.net]
- To cite this document: BenchChem. [Interpreting unexpected results from XY221 experiments]. BenchChem, [2025]. [Online PDF]. Available at: [https://www.benchchem.com/product/b15604862#interpreting-unexpected-results-from-xy221-experiments]

Disclaimer & Data Validity:

The information provided in this document is for Research Use Only (RUO) and is strictly not intended for diagnostic or therapeutic procedures. While BenchChem strives to provide accurate protocols, we make no warranties, express or implied, regarding the fitness of this product for every specific experimental setup.

Technical Support: The protocols provided are for reference purposes. Unsure if this reagent suits your experiment? [[Contact our Ph.D. Support Team for a compatibility check](#)]

Need Industrial/Bulk Grade? [Request Custom Synthesis Quote](#)

BenchChem

Our mission is to be the trusted global source of essential and advanced chemicals, empowering scientists and researchers to drive progress in science and industry.

Contact

Address: 3281 E Guasti Rd
Ontario, CA 91761, United States
Phone: (601) 213-4426
Email: info@benchchem.com