

Interpreting Mass Spectrometry Data: A Comparative Guide to 3-Chloro-2-nitrobenzaldehyde

Author: BenchChem Technical Support Team. **Date:** December 2025

Compound of Interest

Compound Name: 3-Chloro-2-nitrobenzaldehyde

Cat. No.: B1357113

[Get Quote](#)

For researchers and professionals in drug development and analytical chemistry, precise structural elucidation of organic compounds is paramount. Mass spectrometry stands as a cornerstone technique for determining molecular weight and deducing structural features through fragmentation analysis. This guide provides a comparative interpretation of the mass spectrometry data for **3-Chloro-2-nitrobenzaldehyde**, juxtaposed with the well-characterized fragmentation of 4-Chlorobenzaldehyde.

Mass Spectrometry Data Comparison

The electron ionization (EI) mass spectrum of **3-Chloro-2-nitrobenzaldehyde** is predicted to exhibit a distinct fragmentation pattern influenced by the chloro, nitro, and aldehyde functional groups. A comparison with a structurally simpler analogue, 4-Chlorobenzaldehyde, highlights the impact of the nitro group on fragmentation pathways.

Metric	3-Chloro-2-nitrobenzaldehyde	4-Chlorobenzaldehyde
Molecular Formula	C ₇ H ₄ ClNO ₃	C ₇ H ₅ ClO
Molecular Weight	185.56 g/mol [1]	140.57 g/mol
Molecular Ion (M ⁺)	m/z 185/187 (³⁵ Cl/ ³⁷ Cl isotopes)	m/z 140/142 (³⁵ Cl/ ³⁷ Cl isotopes)
Key Fragment Ions (m/z)	155 [M-NO] ⁺ , 139 [M-NO ₂] ⁺ , 111 [M-NO ₂ -CO] ⁺ , 75 [C ₆ H ₄ Cl-CO] ⁺	139 [M-H] ⁺ , 111 [M-CHO] ⁺ , 75 [C ₆ H ₄ -H] ⁺
Base Peak	Likely m/z 139 or 111	m/z 139

Note: The predicted fragmentation for **3-Chloro-2-nitrobenzaldehyde** is based on common fragmentation patterns of nitroaromatic and chloroaromatic compounds. The presence of chlorine results in characteristic isotopic peaks (M⁺ and M+2) with an approximate intensity ratio of 3:1.

Experimental Protocols

A standardized protocol for acquiring mass spectra via Gas Chromatography-Mass Spectrometry (GC-MS) is crucial for reproducibility.

Sample Preparation: A dilute solution of the analyte (e.g., 1 mg/mL) is prepared in a volatile solvent such as dichloromethane or ethyl acetate.

GC-MS Instrumentation and Conditions:

- Gas Chromatograph: Agilent 7890B GC System (or equivalent)
- Mass Spectrometer: Agilent 5977A MSD (or equivalent)
- Ionization Mode: Electron Ionization (EI)[2]
- Electron Energy: 70 eV[2]

- Injector Temperature: 250 °C
- Carrier Gas: Helium at a constant flow of 1 mL/min
- Oven Temperature Program: Initial temperature of 70°C for 2 minutes, followed by a ramp of 10°C/min to 280°C, and a final hold for 5 minutes.
- Mass Range:m/z 40-500
- Source Temperature: 230 °C
- Quadrupole Temperature: 150 °C

Visualization of Fragmentation Pathways

The following diagrams illustrate the proposed electron ionization fragmentation pathways for **3-Chloro-2-nitrobenzaldehyde** and the established fragmentation for 4-Chlorobenzaldehyde.

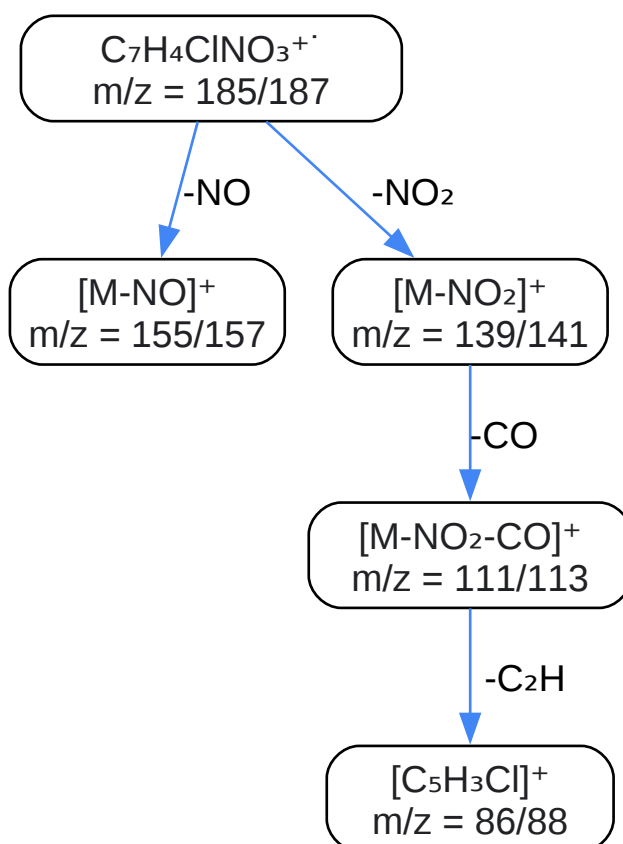

[Click to download full resolution via product page](#)

Predicted EI fragmentation of **3-Chloro-2-nitrobenzaldehyde**.

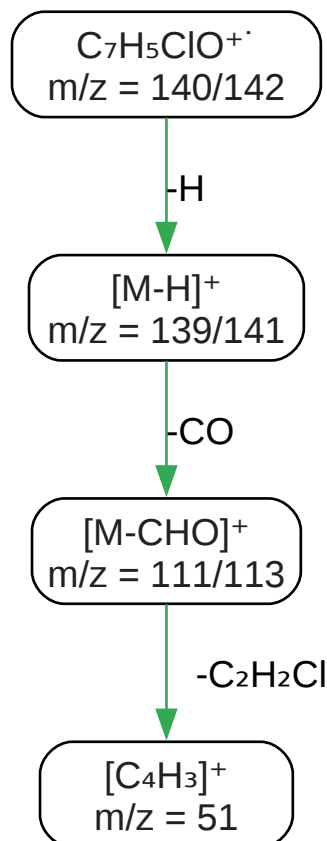

[Click to download full resolution via product page](#)

Established EI fragmentation of 4-Chlorobenzaldehyde.

In summary, the mass spectrum of **3-Chloro-2-nitrobenzaldehyde** is expected to be more complex than that of 4-Chlorobenzaldehyde due to the presence of the nitro group, which introduces additional fragmentation pathways. The initial loss of NO or NO₂ is a characteristic feature of nitroaromatic compounds. Subsequent losses of CO from the aldehyde group are also anticipated. The isotopic signature of chlorine serves as a key identifier in both molecules. This comparative guide provides a framework for interpreting the mass spectrometry data of **3-Chloro-2-nitrobenzaldehyde** and distinguishing it from similar chlorinated benzaldehydes.

Need Custom Synthesis?

BenchChem offers custom synthesis for rare earth carbides and specific isotopic labeling.

Email: info@benchchem.com or [Request Quote Online](#).

References

- 1. pubs.aip.org [pubs.aip.org]
- 2. pubs.aip.org [pubs.aip.org]
- To cite this document: BenchChem. [Interpreting Mass Spectrometry Data: A Comparative Guide to 3-Chloro-2-nitrobenzaldehyde]. BenchChem, [2025]. [Online PDF]. Available at: [https://www.benchchem.com/product/b1357113#interpreting-mass-spectrometry-data-for-3-chloro-2-nitrobenzaldehyde]

Disclaimer & Data Validity:

The information provided in this document is for Research Use Only (RUO) and is strictly not intended for diagnostic or therapeutic procedures. While BenchChem strives to provide accurate protocols, we make no warranties, express or implied, regarding the fitness of this product for every specific experimental setup.

Technical Support: The protocols provided are for reference purposes. Unsure if this reagent suits your experiment? [[Contact our Ph.D. Support Team for a compatibility check](#)]

Need Industrial/Bulk Grade? [Request Custom Synthesis Quote](#)

BenchChem

Our mission is to be the trusted global source of essential and advanced chemicals, empowering scientists and researchers to drive progress in science and industry.

Contact

Address: 3281 E Guasti Rd
Ontario, CA 91761, United States
Phone: (601) 213-4426
Email: info@benchchem.com