

# Independent Validation of Recoflavone Research: A Comparative Guide for Drug Development Professionals

**Author:** BenchChem Technical Support Team. **Date:** December 2025

## Compound of Interest

Compound Name: *Recoflavone*

Cat. No.: *B1679252*

[Get Quote](#)

For Researchers, Scientists, and Drug Development Professionals

This guide provides an objective comparison of the published research findings on **Recoflavone**, a novel treatment for dry eye disease, with established alternatives. The information is intended to offer a consolidated resource for evaluating the current evidence base for this new therapeutic agent.

## Executive Summary

**Recoflavone** (formerly DA-6034) is a new drug candidate developed by GL PharmTech and Aju Pharmaceutical that has recently completed Phase 3 clinical trials in South Korea for the treatment of dry eye disease.[1][2] Preclinical and clinical studies suggest a multi-faceted mechanism of action, including anti-inflammatory effects, stimulation of tear and mucin secretion, and corneal tissue repair.[1] This guide summarizes the available quantitative data from clinical trials of **Recoflavone** and its major competitors, details the experimental protocols from key preclinical studies, and visualizes the proposed signaling pathways and experimental workflows.

## Quantitative Data Comparison

The following tables summarize the available efficacy data from clinical trials of **Recoflavone** and two leading prescription treatments for dry eye disease: cyclosporine and lifitegrast. It is

important to note that the full data from the **Recoflavone** Phase 3 trial has not yet been published in a peer-reviewed journal. The data presented here for **Recoflavone** is from a Phase 2 clinical trial.

Table 1: Comparison of Efficacy Endpoints for **Recoflavone**, Cyclosporine, and Lifitegrast

Drug	Clinical Trial Phase	Primary Efficacy Endpoint	Change from Baseline (Drug)	Change from Baseline (Placebo/Vehicle)	p-value	Citation
Recoflavone (DA-6034)	2	Total Corneal Staining Score (TCSS) at week 4	Data not fully reported	Data not fully reported	p=0.0398 (3x/day), p=0.0442 (6x/day)	[3]
Ocular Discomfort Score (ODS) at week 4	Data not fully reported	Data not fully reported	p=0.0379 (3x/day), p=0.0164 (6x/day)	[3]		
Lissamine Green Conjunctival Staining (LGCS) at week 4	Data not fully reported	Data not fully reported	p=0.0014 (6x/day)	[3]		
Cyclosporine 0.05%	3	Corneal Staining	Significantly greater improvement than vehicle	Not specified	p ≤ 0.05	[4]
Blurred Vision	Significantly greater improvement than vehicle	Not specified	p < 0.05	[4]		
Lifitegrast 5%	3	Eye Dryness	-16.84	-9.68	p = 0.0007	[5]

(OPUS-3)

 Score  
(EDS) at  
day 84

 Eye  
Dryness  
Score  
(EDS) at  
day 42

-15.53	-6.21	p < 0.0001	[5]
--------	-------	------------	-----

 Eye  
Dryness  
Score  
(EDS) at  
day 14

-12.28	-4.43	p < 0.0001	[5]
--------	-------	------------	-----

Note: Direct comparison between these trials is challenging due to differences in study design, patient populations, and scoring methodologies.

## Experimental Protocols

Detailed methodologies for key preclinical experiments that elucidated the mechanism of action of **Recoflavone** (DA-6034) are provided below.

## In Vitro Anti-inflammatory Effect Assessment

- Cell Line: Human Corneal Epithelial (HCE) cells.
- Induction of Inflammation: Cells were stimulated with Pam3Cys (a TLR2 agonist) to induce an inflammatory response.
- Treatment: HCE cells were pre-treated with varying concentrations of DA-6034 for 1 hour before stimulation with Pam3Cys.
- Endpoint Analysis: The levels of phosphorylated MAPKs (JNK and p38) and NF-κB were measured using an enzyme-linked immunosorbent assay (ELISA).

- Outcome: DA-6034 was found to inhibit the phosphorylation of JNK and p38 MAPK and suppress NF- $\kappa$ B activation in a concentration-dependent manner.

## Animal Model of Dry Eye

- Animal Model: A dry eye mouse model was induced using scopolamine hydrobromide injections and desiccation stress.
- Treatment Groups: Mice were treated with vehicle, DA-6034, Diquafosol (DQS), or Rebamipide (REB) for 21 days.
- Efficacy Assessments:
  - Clinical Analysis: Tear production, corneal irregularity, and fluorescein staining were assessed at multiple time points.
  - Histological Analysis: Corneal epithelial cell detachment, conjunctival goblet cell density, and mucin density were evaluated.
  - Immunohistochemical Analysis: Expression levels of inflammatory markers (TNF- $\alpha$ , MMP-9, IL-1 $\beta$ , IL-6, and NF- $\kappa$ B) in the lacrimal glands were assessed.
- Outcome: DA-6034 showed significant improvements in tear production and corneal epithelial cell detachment, comparable to DQS and REB. It demonstrated superior anti-inflammatory effects compared to DQS and induced more mucin secretion than both DQS and REB.[\[6\]](#)

## Visualizations

### Signaling Pathways

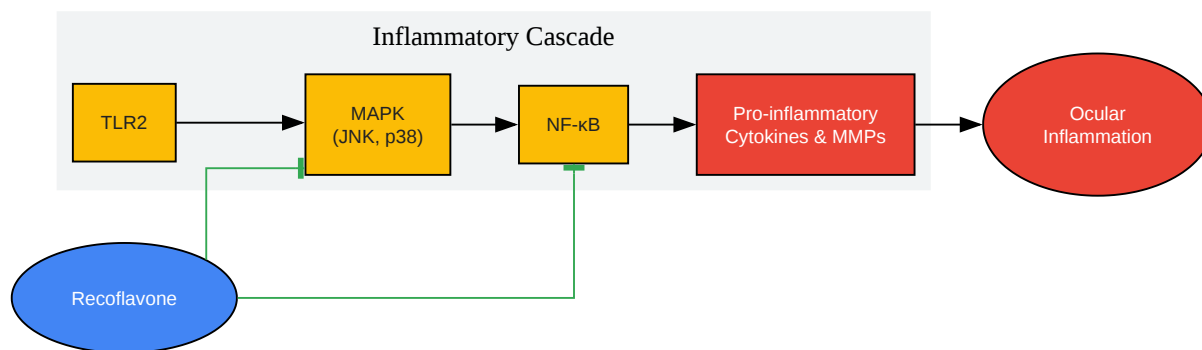

[Click to download full resolution via product page](#)

Caption: Proposed anti-inflammatory signaling pathway of **Recoflavone**.

## Experimental Workflow

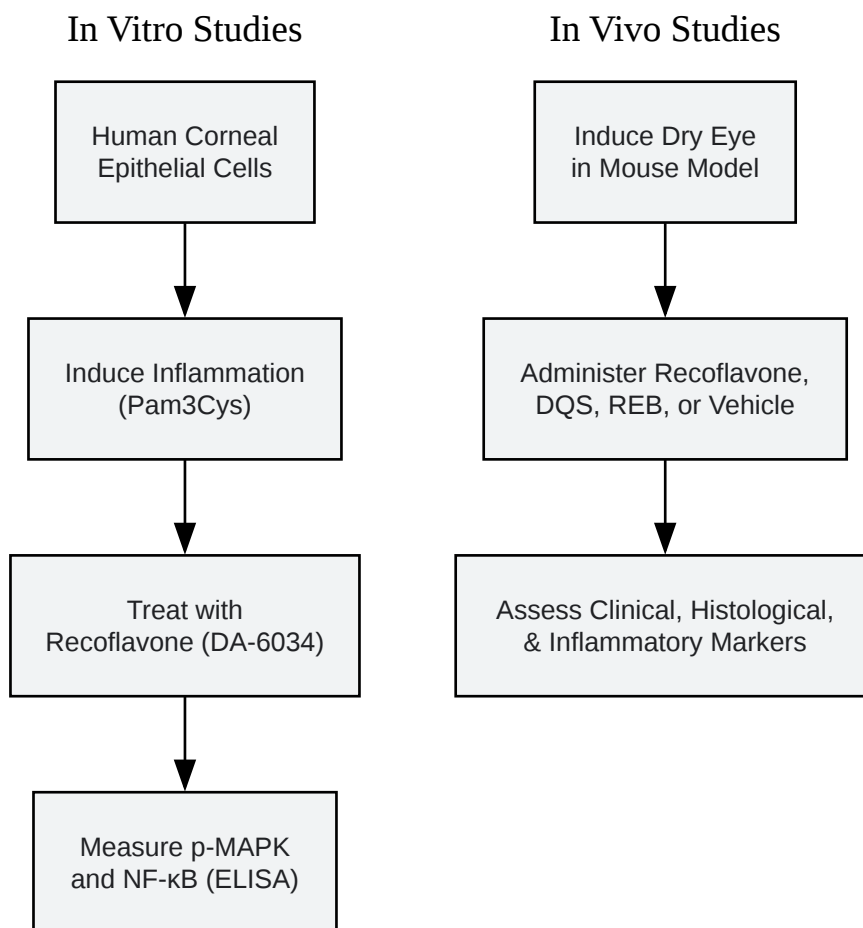

[Click to download full resolution via product page](#)

Caption: Preclinical experimental workflow for **Recoflavone**.

## Logical Relationships

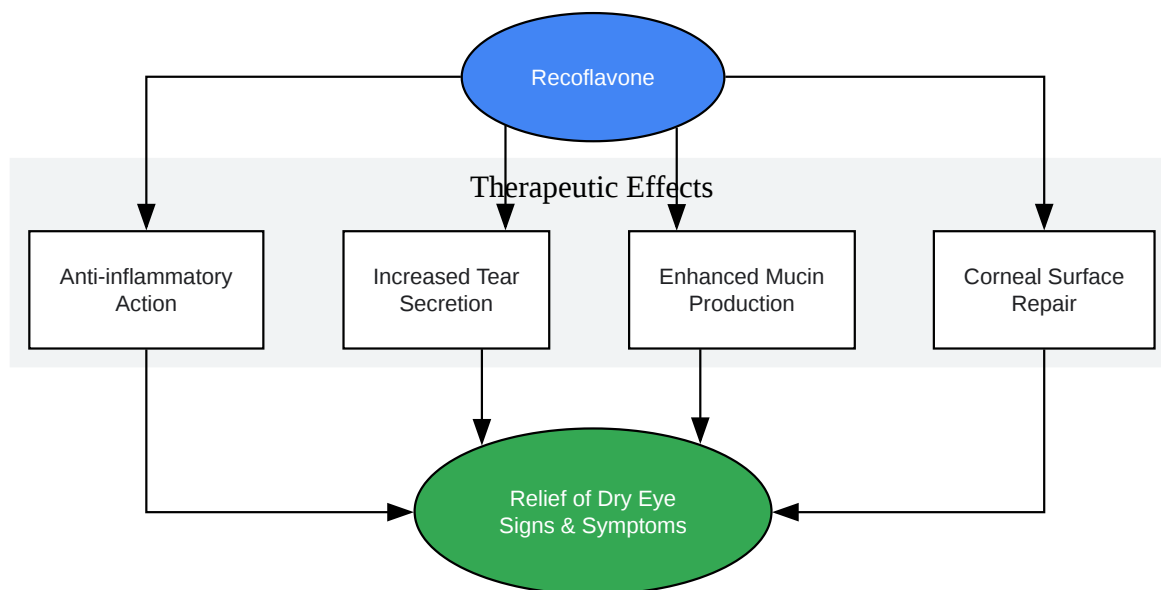

[Click to download full resolution via product page](#)

Caption: Logical relationship of **Recoflavone**'s mechanisms of action.

## Conclusion and Future Directions

The available preclinical data for **Recoflavone** (DA-6034) are promising, suggesting a multifactorial mechanism of action that addresses key aspects of dry eye disease pathophysiology. The successful completion of the Phase 3 clinical trial is a significant milestone. However, for a comprehensive and independent validation, the full, peer-reviewed publication of the Phase 3 clinical trial data is essential. This will allow for a more direct and robust comparison with existing therapies. Furthermore, independent studies replicating the preclinical findings would strengthen the evidence base for **Recoflavone**'s mechanism of action. Head-to-head clinical trials comparing **Recoflavone** with cyclosporine and lifitegrast will be crucial to definitively establish its relative efficacy and safety profile in the management of dry eye disease.

### Need Custom Synthesis?

BenchChem offers custom synthesis for rare earth carbides and specific isotopic labeling.

Email: [info@benchchem.com](mailto:info@benchchem.com) or [Request Quote Online](#).



## References

- 1. GL PharmTech's Recoflavone Proves Efficacy in Phase 3 Dry Eye Trial < PharmaBio HIT-Digest < 제약 < 기업 < 기사본문 - 히트뉴스 [hitnews.co.kr]
- 2. GL PharmTech's Dry Eye Drug Candidate Set for Market Launch Following Phase 3 Success - Businesskorea [businesskorea.co.kr]
- 3. iovs.arvojournals.org [iovs.arvojournals.org]
- 4. Two multicenter, randomized studies of the efficacy and safety of cyclosporine ophthalmic emulsion in moderate to severe dry eye disease. CsA Phase 3 Study Group - PubMed [pubmed.ncbi.nlm.nih.gov]
- 5. Lifitegrast for the Treatment of Dry Eye Disease: Results of a Phase III, Randomized, Double-Masked, Placebo-Controlled Trial (OPUS-3) - PubMed [pubmed.ncbi.nlm.nih.gov]
- 6. iovs.arvojournals.org [iovs.arvojournals.org]
- To cite this document: BenchChem. [Independent Validation of Recoflavone Research: A Comparative Guide for Drug Development Professionals]. BenchChem, [2025]. [Online PDF]. Available at: [<https://www.benchchem.com/product/b1679252#independent-validation-of-published-recoflavone-research-findings>]

---

### Disclaimer & Data Validity:

The information provided in this document is for Research Use Only (RUO) and is strictly not intended for diagnostic or therapeutic procedures. While BenchChem strives to provide accurate protocols, we make no warranties, express or implied, regarding the fitness of this product for every specific experimental setup.

**Technical Support:** The protocols provided are for reference purposes. Unsure if this reagent suits your experiment? [[Contact our Ph.D. Support Team for a compatibility check](#)]

**Need Industrial/Bulk Grade?** [Request Custom Synthesis Quote](#)

# BenchChem

Our mission is to be the trusted global source of essential and advanced chemicals, empowering scientists and researchers to drive progress in science and industry.

## Contact

Address: 3281 E Guasti Rd

Ontario, CA 91761, United States

Phone: (601) 213-4426

Email: [info@benchchem.com](mailto:info@benchchem.com)