

Independent Validation of Haplo toxin-2's Mechanism of Action: A Comparative Guide

Author: BenchChem Technical Support Team. **Date:** December 2025

Compound of Interest

Compound Name: *Haplo toxin-2*

Cat. No.: *B15600393*

[Get Quote](#)

For Researchers, Scientists, and Drug Development Professionals

This guide provides an objective comparison of the hypothetical toxin, **Haplo toxin-2**, with other well-characterized toxins, supported by established experimental data and detailed methodologies for validation. **Haplo toxin-2** is presented here as a potent and highly selective blocker of the voltage-gated sodium channel subtype Nav1.7, a key target in pain signaling pathways.^{[1][2]} This document serves as a framework for the independent validation of its mechanism of action.

Comparison with Alternative Toxins

The efficacy and mechanism of a novel toxin are best understood in the context of known alternatives. The following table summarizes the key characteristics of **Haplo toxin-2** in comparison to other toxins that modulate ion channel activity.

Toxin	Target Ion Channel(s)	Mechanism of Action	Potency (IC50/EC50)	Source Organism
Haplo toxin-2 (Hypothetical)	Nav1.7	Pore Blocker: Physically obstructs the ion-conducting pore, preventing sodium influx and action potential propagation.	~5 nM	Fictitious Arachnid
Tetrodotoxin (TTX)	Nav1.1, Nav1.2, Nav1.3, Nav1.4, Nav1.6, Nav1.7[1][3]	Pore Blocker: Binds to the outer pore of the channel, physically blocking sodium ion passage.[3][4][5]	~1-10 nM (for sensitive subtypes)[1]	Pufferfish, Octopus, etc.[3]
Batrachotoxin (BTX)	Voltage-gated sodium channels[6][7]	Channel Activator: Binds to the channel and causes it to open at resting membrane potentials and remain open, leading to persistent depolarization.[6][7][8]	Potent activator	Poison dart frogs[7]
α-Scorpion Toxins (e.g., LqhII)	Voltage-gated sodium channels[9][10]	Gating Modifier (Inactivation): Binds to the extracellular loop	Varies by specific toxin	Scorpions[9]

		of the channel, slowing or inhibiting fast inactivation and prolonging the action potential. [10][11][12]		
δ -Conotoxins	Voltage-gated sodium channels	Gating Modifier (Activation): Slows the inactivation of voltage-gated sodium channels.[13]	Varies by specific toxin	Cone snails[13]
ω -Conotoxin (e.g., MVIIA)	N-type voltage-gated calcium channels	Pore Blocker: Selectively blocks N-type calcium channels, inhibiting neurotransmitter release.[13][14]	Varies by specific toxin	Cone snails

Experimental Protocols for Validation

Independent validation of **Haplotoxin-2**'s mechanism of action requires a multi-faceted approach, employing a combination of electrophysiological, cell-based, and in vivo assays.

Electrophysiology: Patch-Clamp Analysis

The gold standard for characterizing ion channel modulators is the patch-clamp technique.[15] [16] This method allows for direct measurement of ion channel currents in live cells.

- Objective: To determine the effect of **Haplotoxin-2** on the biophysical properties of Nav1.7 channels.

- Cell Line: Human embryonic kidney (HEK293) cells stably expressing human Nav1.7 channels.
- Protocol:
 - Culture HEK293-Nav1.7 cells to 70-80% confluency.
 - Prepare whole-cell patch-clamp recordings. Pipettes should have a resistance of 2-5 M Ω when filled with an internal solution containing (in mM): 140 CsF, 10 NaCl, 1 EGTA, and 10 HEPES, pH 7.3 with CsOH. The external solution should contain (in mM): 140 NaCl, 5 KCl, 2 CaCl₂, 1 MgCl₂, 10 HEPES, and 10 glucose, pH 7.4 with NaOH.
 - Establish a stable gigaohm seal and obtain the whole-cell configuration.
 - Record baseline Nav1.7 currents by applying a voltage step protocol (e.g., depolarizing steps from a holding potential of -120 mV).
 - Perfuse the cells with increasing concentrations of **Haplotoxin-2** and record the resulting changes in current amplitude and kinetics.
 - To determine the IC₅₀, construct a dose-response curve by plotting the percentage of current inhibition against the logarithm of the **Haplotoxin-2** concentration.
 - Assess the voltage-dependence of the block by applying the toxin at different holding potentials.
 - Investigate the effect of **Haplotoxin-2** on channel gating by analyzing changes in the voltage-dependence of activation and inactivation.

Cell-Based Assay: Fluorescence-Based Ion Flux Assay

This high-throughput assay provides an indirect measure of ion channel activity and is suitable for screening and initial characterization.[\[17\]](#)[\[18\]](#)[\[19\]](#)

- Objective: To confirm the inhibitory effect of **Haplotoxin-2** on Nav1.7-mediated sodium influx in a cell population.
- Cell Line: HEK293 cells stably expressing human Nav1.7.

- Protocol:
 - Plate HEK293-Nav1.7 cells in a 96-well or 384-well black-walled, clear-bottom plate.
 - Load the cells with a sodium-sensitive fluorescent indicator dye (e.g., Sodium Green™ or ANG-2) according to the manufacturer's instructions.
 - Prepare a solution of **Haplotoxin-2** at various concentrations.
 - Use a fluorescence plate reader to measure the baseline fluorescence.
 - Add a Nav1.7 channel activator (e.g., veratridine) to stimulate sodium influx, followed immediately by the addition of **Haplotoxin-2** or a vehicle control.
 - Record the change in fluorescence over time. Inhibition of the fluorescence signal in the presence of **Haplotoxin-2** indicates a blockade of sodium influx.
 - Calculate the IC50 from the dose-response curve.

In Vivo Assay: Animal Model of Pain

To assess the physiological relevance of Nav1.7 blockade by **Haplotoxin-2**, in vivo studies using established animal models of pain are crucial.[\[20\]](#)[\[21\]](#)[\[22\]](#)

- Objective: To evaluate the analgesic efficacy of **Haplotoxin-2** in a preclinical pain model.
- Animal Model: Complete Freund's Adjuvant (CFA)-induced inflammatory pain model in rats or mice.
- Protocol:
 - Induce inflammation by injecting CFA into the plantar surface of one hind paw of the animal.
 - After a set period for inflammation to develop (e.g., 24 hours), assess baseline pain behavior using tests for thermal hyperalgesia (e.g., Hargreaves test) and mechanical allodynia (e.g., von Frey filaments).

- Administer **Haplotoxin-2** systemically (e.g., via intravenous or subcutaneous injection) or locally (e.g., intraplantar injection) at various doses. A vehicle control group and a positive control group (e.g., morphine) should be included.
- At different time points after drug administration, re-assess thermal and mechanical pain thresholds.
- A significant increase in the paw withdrawal latency (thermal) or threshold (mechanical) in the **Haplotoxin-2**-treated group compared to the vehicle group indicates an analgesic effect.
- Construct a dose-response curve to determine the effective dose (ED50).

Visualizing Mechanisms and Workflows

To further clarify the proposed mechanism of **Haplotoxin-2** and the experimental approaches for its validation, the following diagrams are provided.

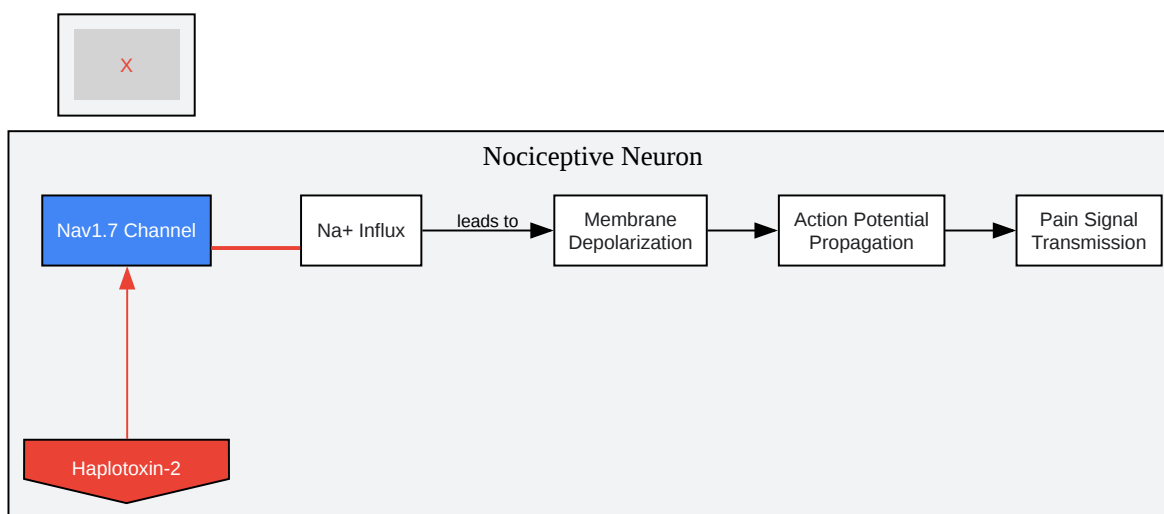

[Click to download full resolution via product page](#)

Caption: Proposed mechanism of **Haplotoxin-2** action.

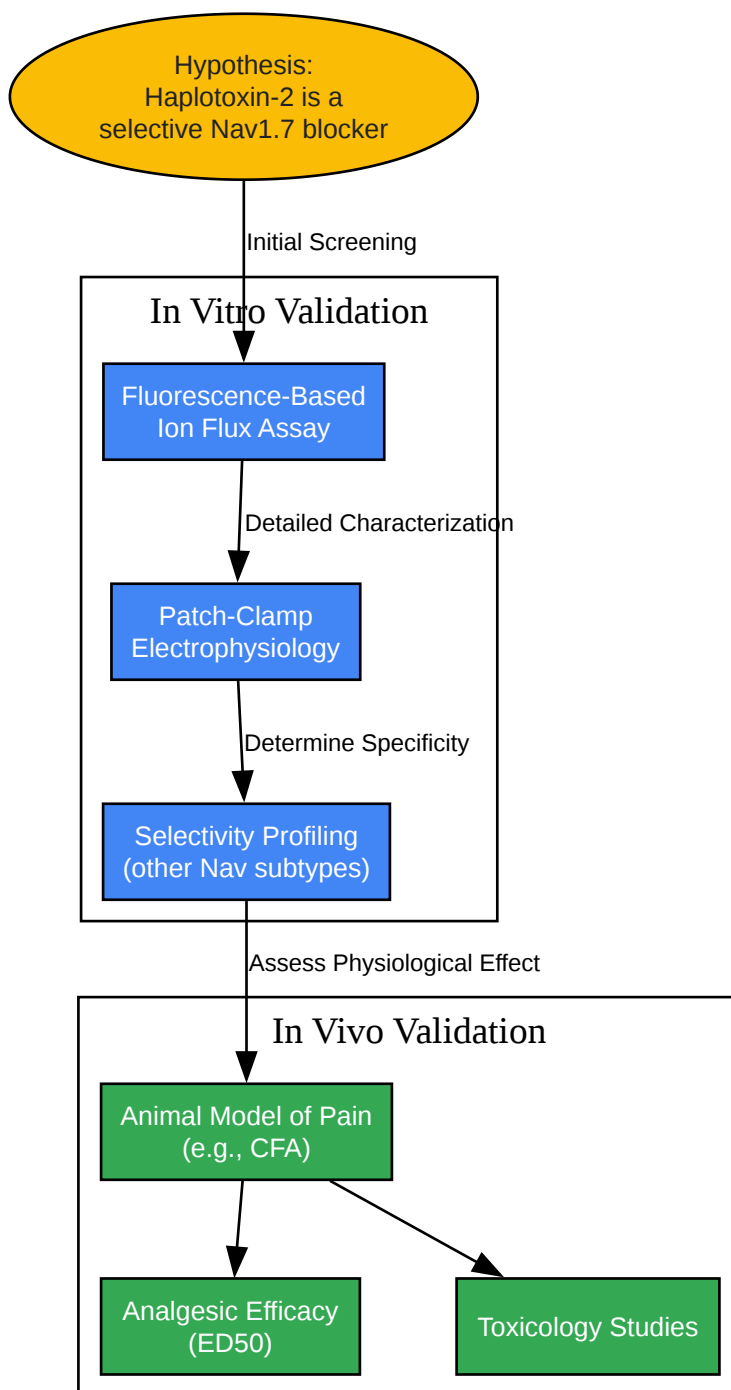

[Click to download full resolution via product page](#)

Caption: Experimental workflow for **Haplotoxin-2** validation.

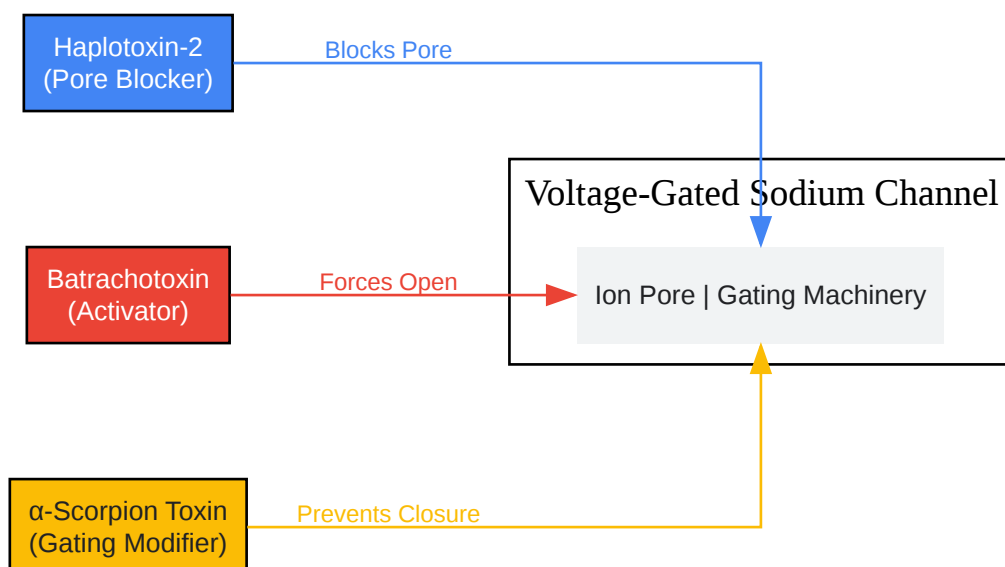

[Click to download full resolution via product page](#)

Caption: Comparison of toxin mechanisms of action.

Need Custom Synthesis?

BenchChem offers custom synthesis for rare earth carbides and specific isotopic labeling.

Email: info@benchchem.com or [Request Quote Online](#).

References

- 1. Nav1.7 and other voltage-gated sodium channels as drug targets for pain relief - PMC [pmc.ncbi.nlm.nih.gov]
- 2. Nav1.7 channels: advancing preclinical models for pain drug discovery - Nanion Technologies [nanion.de]
- 3. creative-diagnostics.com [creative-diagnostics.com]
- 4. Tetrodotoxin Toxicity - StatPearls - NCBI Bookshelf [ncbi.nlm.nih.gov]
- 5. Tetrodotoxin Structure, Mechanism & Effects | Study.com [study.com]
- 6. Batrachotoxin | 23509-16-2 | Benchchem [benchchem.com]
- 7. Batrachotoxin - Wikipedia [en.wikipedia.org]
- 8. Batrachotoxin | C31H42N2O6 | CID 6324647 - PubChem [pubchem.ncbi.nlm.nih.gov]

- 9. Scorpion toxin - Wikipedia [en.wikipedia.org]
- 10. Voltage-gated sodium channel modulation by scorpion α -toxins - PMC [pmc.ncbi.nlm.nih.gov]
- 11. Deciphering Scorpion Toxin-Induced Pain: Molecular Mechanisms and Ion Channel Dynamics - PMC [pmc.ncbi.nlm.nih.gov]
- 12. Scorpion Peptides and Ion Channels: An Insightful Review of Mechanisms and Drug Development - PMC [pmc.ncbi.nlm.nih.gov]
- 13. scispace.com [scispace.com]
- 14. mdpi.com [mdpi.com]
- 15. Electrophysiological evaluation of the effect of peptide toxins on voltage-gated ion channels: a scoping review on theoretical and methodological aspects with focus on the Central and South American experience - PMC [pmc.ncbi.nlm.nih.gov]
- 16. scielo.br [scielo.br]
- 17. Ion Channel Flux Assays and Protocols [sigmaaldrich.com]
- 18. Ion Channel Screening - Assay Guidance Manual - NCBI Bookshelf [ncbi.nlm.nih.gov]
- 19. acrossell.creative-bioarray.com [acrossell.creative-bioarray.com]
- 20. Animal Models for Pain Research | Neuropathic & Chronic Pain - Aragen Life Sciences [aragen.com]
- 21. An overview of animal models of pain: disease models and outcome measures - PMC [pmc.ncbi.nlm.nih.gov]
- 22. iasp-pain.org [iasp-pain.org]
- To cite this document: BenchChem. [Independent Validation of Haplotxin-2's Mechanism of Action: A Comparative Guide]. BenchChem, [2025]. [Online PDF]. Available at: [https://www.benchchem.com/product/b15600393#independent-validation-of-haplotxin-2-s-mechanism-of-action]

Disclaimer & Data Validity:

The information provided in this document is for Research Use Only (RUO) and is strictly not intended for diagnostic or therapeutic procedures. While BenchChem strives to provide accurate protocols, we make no warranties, express or implied, regarding the fitness of this product for every specific experimental setup.

Technical Support: The protocols provided are for reference purposes. Unsure if this reagent suits your experiment? [[Contact our Ph.D. Support Team for a compatibility check](#)]

Need Industrial/Bulk Grade? [Request Custom Synthesis Quote](#)

BenchChem

Our mission is to be the trusted global source of essential and advanced chemicals, empowering scientists and researchers to drive progress in science and industry.

Contact

Address: 3281 E Guasti Rd

Ontario, CA 91761, United States

Phone: (601) 213-4426

Email: info@benchchem.com