

In Vivo Therapeutic Efficacy of Zedoarondiol: A Comparative Guide

Author: BenchChem Technical Support Team. **Date:** December 2025

Compound of Interest

Compound Name: *Methylzedoarondiol*

Cat. No.: *B12403117*

[Get Quote](#)

For Researchers, Scientists, and Drug Development Professionals

This guide provides a comparative analysis of the in vivo therapeutic effects of Zedoarondiol, a sesquiterpenoid isolated from *Curcuma zedoaria* (Zedoary), in the context of its potential anticancer and anti-inflammatory applications. Due to the limited availability of in vivo studies on isolated Zedoarondiol for anticancer evaluation, this guide utilizes data from studies on Zedoary essential oil, of which Zedoarondiol is a known component, as a proxy. This is compared against established therapeutic alternatives, with supporting experimental data and detailed protocols.

Anticancer Therapeutic Effects: Zedoary Oil vs. Standard Chemotherapy

Zedoary essential oil has demonstrated significant antitumor activity in preclinical models of non-small cell lung carcinoma (NSCLC). This section compares its efficacy with standard-of-care chemotherapeutic agents, cisplatin and docetaxel.

Quantitative Data Summary

Treatment	Animal Model	Cell Line	Dosage	Administration Route	Tumor Growth Inhibition (%)	Reference
Zedoary Essential Oil	BALB/c nude mice	H1299 (NSCLC)	240 mg/kg	Intraperitoneal (i.p.)	Significant suppression of tumor growth (quantitative % not specified)	[1]
Cisplatin	Nude mice	H526 (SCLC)	3.0 mg/kg	Intraperitoneal (i.p.)	Cessation of exponential tumor growth for at least 3 days	[2][3]
Docetaxel	Nude mice	A549 (NSCLC)	5 mg/kg	Not specified	~40%	[4]

Experimental Protocols

Zedoary Essential Oil in NSCLC Xenograft Model

- Animal Model: Male BALB/c (nu/nu) nude mice (6 weeks old).
- Cell Line and Implantation: Human non-small cell lung carcinoma (H1299) cells were implanted subcutaneously.
- Treatment: Mice were treated with Zedoary essential oil (2.4, 12, 60, and 240 mg/kg) via intraperitoneal administration five times a week. The control group received a 10% ethanol/PBS mixture.
- Efficacy Evaluation: Tumor volume and weight were measured to assess antitumor activity.

Cisplatin in SCLC Xenograft Model[2][3]

- Animal Model: Mice bearing H526 small cell lung cancer xenografts.
- Treatment: A high dose of cisplatin (3.0 mg/kg) was administered intraperitoneally.
- Efficacy Evaluation: Tumor response was recorded by measuring tumor volume. A positive result was indicated by the cessation of exponential tumor growth for at least 3 days.

Docetaxel in NSCLC Xenograft Model[4]

- Animal Model: Nude mice with A549 non-small cell lung cancer xenografts.
- Treatment: Docetaxel was administered at a dose of 5 mg/kg for 3 weeks.
- Efficacy Evaluation: The tumor growth inhibition rate was calculated to be approximately 40%.

Signaling Pathways

Zedoary essential oil has been shown to inhibit the AKT/NF- κ B signaling pathways and modulate the MAPK pathway in H1299 cells.[1]

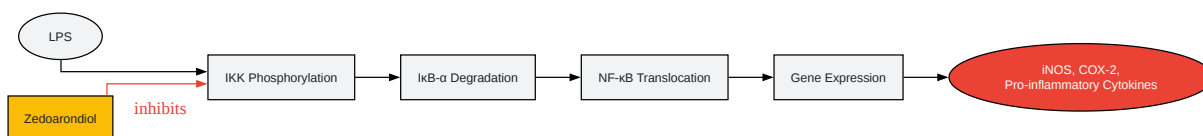
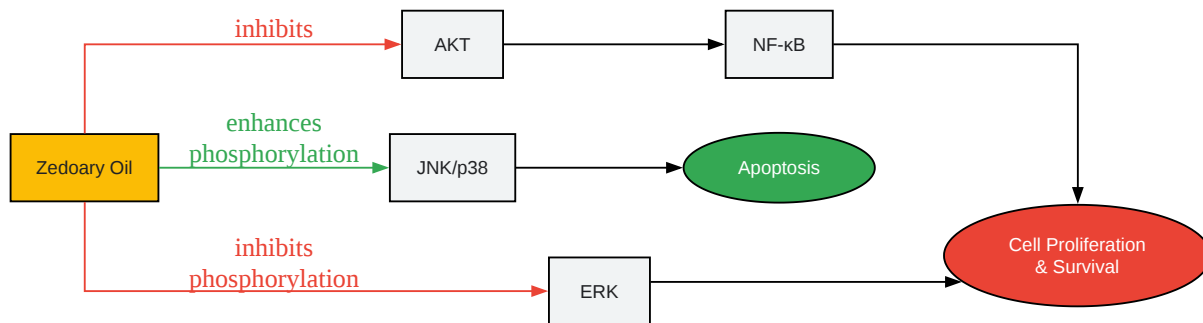

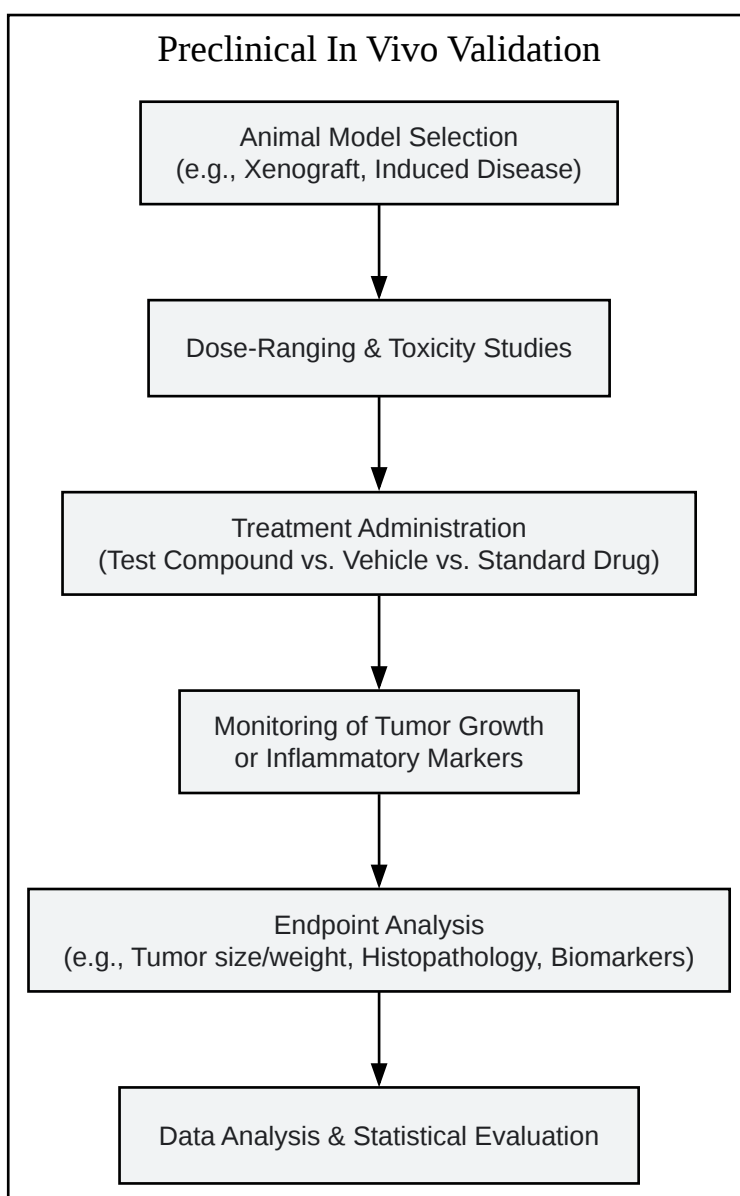

[Click to download full resolution via product page](#)

Need Custom Synthesis?

BenchChem offers custom synthesis for rare earth carbides and specific isotopic labeling.

Email: info@benchchem.com or [Request Quote Online](#).

References

- 1. pubs.acs.org [pubs.acs.org]
- 2. A Model of the Development of Cisplatin Resistance in Human Small Cell Lung Cancer Xenografts - PubMed [pubmed.ncbi.nlm.nih.gov]
- 3. A Model of the Development of Cisplatin Resistance in Human Small Cell Lung Cancer Xenografts | In Vivo [iv.iiarjournals.org]
- 4. oncotarget.com [oncotarget.com]
- To cite this document: BenchChem. [In Vivo Therapeutic Efficacy of Zedoarondiol: A Comparative Guide]. BenchChem, [2025]. [Online PDF]. Available at: [<https://www.benchchem.com/product/b12403117#in-vivo-validation-of-methylzedoarondiol-therapeutic-effects>]

Disclaimer & Data Validity:

The information provided in this document is for Research Use Only (RUO) and is strictly not intended for diagnostic or therapeutic procedures. While BenchChem strives to provide accurate protocols, we make no warranties, express or implied, regarding the fitness of this product for every specific experimental setup.

Technical Support: The protocols provided are for reference purposes. Unsure if this reagent suits your experiment? [[Contact our Ph.D. Support Team for a compatibility check](#)]

Need Industrial/Bulk Grade? [Request Custom Synthesis Quote](#)

BenchChem

Our mission is to be the trusted global source of essential and advanced chemicals, empowering scientists and researchers to drive progress in science and industry.

Contact

Address: 3281 E Guasti Rd
Ontario, CA 91761, United States
Phone: (601) 213-4426
Email: info@benchchem.com