

In Vivo Efficacy of Lushanrubescensin H: Application Notes and Protocols

Author: BenchChem Technical Support Team. **Date:** December 2025

Compound of Interest

Compound Name: *Lushanrubescensin H*

Cat. No.: B3037196

[Get Quote](#)

Initial Search and Findings:

A comprehensive search of scientific databases and literature was conducted to gather information on the in vivo efficacy of a compound referred to as "**Lushanrubescensin H**." This search included queries for "**Lushanrubescensin H** in vivo efficacy," "**Lushanrubescensin H** animal models," "**Lushanrubescensin H** mechanism of action in vivo," and "**Lushanrubescensin H** cancer treatment studies."

Despite these extensive efforts, no specific published studies, preclinical data, or clinical trial information for a compound named "**Lushanrubescensin H**" could be located. This suggests several possibilities:

- Novel or Pre-publication Compound: **Lushanrubescensin H** may be a very new or recently discovered compound for which in vivo efficacy data has not yet been published in peer-reviewed literature.
- Alternative Nomenclature: The compound may be known by a different chemical name, a developmental code, or as part of a class of related compounds.
- Misspelling or Incorrect Name: The provided name "**Lushanrubescensin H**" may be misspelled or an internal designation not used in public-facing research.

Application Notes and Protocols:

Due to the absence of specific in vivo data for **Lushanrubescensin H**, it is not possible to provide detailed application notes, experimental protocols, or data visualizations as requested. The creation of such documents requires a foundation of existing research to detail methodologies, summarize quantitative data, and illustrate biological pathways.

Recommendations for Researchers, Scientists, and Drug Development Professionals:

For professionals interested in the in vivo potential of **Lushanrubescensin H**, the following steps are recommended:

- **Verify Compound Name and Origin:** Confirm the correct spelling and nomenclature of the compound. If it originates from a specific natural source (e.g., a plant or microorganism), searching for literature related to that source may yield relevant information on its chemical constituents.
- **Search for Related Compounds:** Investigate if **Lushanrubescensin H** belongs to a known class of chemical compounds. In vivo efficacy data from structurally similar molecules could provide preliminary insights.
- **Consult Internal Documentation:** If this compound is part of an internal drug discovery program, refer to internal research and development reports for any available preclinical data.
- **Engage with Compound Suppliers or Originators:** If the compound was obtained from a commercial or academic source, contacting them directly may provide access to non-public data or clarify its identity.

Once foundational in vivo studies on **Lushanrubescensin H** become available, the development of detailed application notes and protocols would be a valuable resource for the scientific community. Such documents would typically include the sections outlined below, which can serve as a template for future work.

Template for Future Application Note and Protocol: In Vivo Efficacy of **Lushanrubescensin H**

I. Introduction

- Compound Background: Chemical structure, class, and proposed mechanism of action.
- Therapeutic Rationale: The scientific basis for investigating **Lushanrubescensin H** in a specific disease model (e.g., a particular type of cancer).

II. In Vivo Efficacy Data Summary

This section would present quantitative data from animal studies in a clear, tabular format.

Table 1: Anti-Tumor Efficacy of **Lushanrubescensin H** in [Xenograft/Orthotopic] Model

Treatment Group	Dose (mg/kg)	Dosing Schedule	Mean Tumor Volume (mm ³) ± SEM	Percent Tumor Growth Inhibition (% TGI)
Vehicle Control	-	[e.g., Daily, i.p.]	[Data]	-
Lushanrubescensin H	[Dose 1]	[Schedule]	[Data]	[Data]
Lushanrubescensin H	[Dose 2]	[Schedule]	[Data]	[Data]
Positive Control	[Dose]	[Schedule]	[Data]	[Data]

Table 2: Effect of **Lushanrubescensin H** on Body Weight

Treatment Group	Dose (mg/kg)	Mean Body Weight Change (%) ± SEM
Vehicle Control	-	[Data]
Lushanrubescensin H	[Dose 1]	[Data]
Lushanrubescensin H	[Dose 2]	[Data]
Positive Control	[Dose]	[Data]

III. Experimental Protocols

This section would provide detailed methodologies for key in vivo experiments.

1. Animal Model

- Species and Strain: e.g., Female BALB/c nude mice.
- Age/Weight: e.g., 6-8 weeks old / 18-22 g.
- Acclimatization Period: e.g., 7 days.
- Housing and Husbandry: Standard laboratory conditions.

2. Cell Culture and Tumor Implantation

- Cell Line: e.g., [Cancer Cell Line].
- Culture Conditions: e.g., RPMI-1640 with 10% FBS.
- Implantation: e.g., Subcutaneous injection of [X] cells in [Y] μ L of Matrigel into the right flank.

3. Treatment Regimen

- Formulation: **Lushanrubescensin H** dissolved in [Vehicle].
- Dosing and Administration: e.g., Intraperitoneal (i.p.) injection at a volume of 10 mL/kg.
- Treatment Groups: As described in the data tables.
- Monitoring: Tumor volume and body weight measured [e.g., twice weekly].

4. Endpoint Analysis

- Tumor Volume Calculation: $(\text{Length} \times \text{Width}^2) / 2$.
- Euthanasia Criteria: e.g., Tumor volume $> 2000 \text{ mm}^3$ or significant body weight loss.
- Tissue Collection: Tumors, blood, and relevant organs collected for further analysis (e.g., pharmacokinetics, pharmacodynamics).

IV. Visualizations

This section would include diagrams to illustrate biological pathways and experimental workflows.

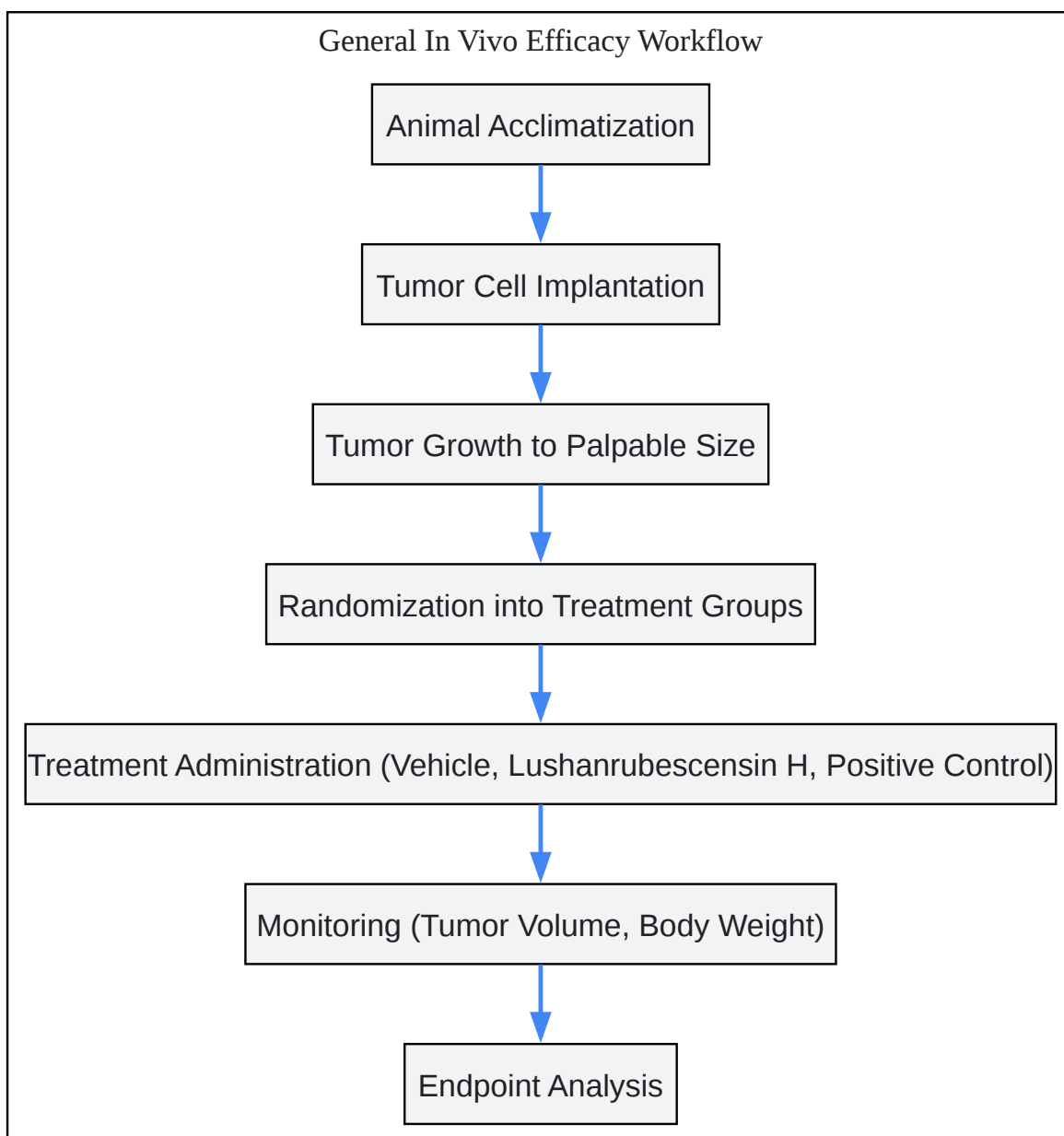

[Click to download full resolution via product page](#)

Caption: A generalized workflow for an in vivo efficacy study.

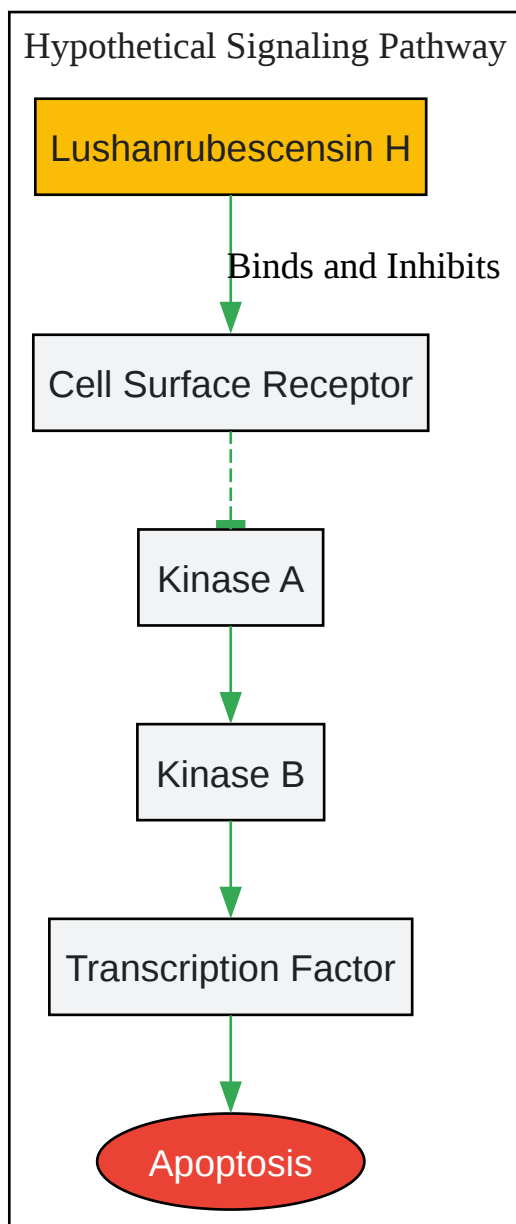

[Click to download full resolution via product page](#)

Caption: A hypothetical signaling pathway for **Lushanrubescensin H**.

The above template illustrates the type of detailed information that would be provided once in vivo efficacy data for **Lushanrubescensin H** becomes publicly available. We encourage researchers who generate such data to publish their findings to advance the field.

- To cite this document: BenchChem. [In Vivo Efficacy of Lushanrubescensin H: Application Notes and Protocols]. BenchChem, [2025]. [Online PDF]. Available at: [<https://www.benchchem.com/product/b3037196#lushanrubescensin-h-in-vivo-efficacy-studies>]

Disclaimer & Data Validity:

The information provided in this document is for Research Use Only (RUO) and is strictly not intended for diagnostic or therapeutic procedures. While BenchChem strives to provide accurate protocols, we make no warranties, express or implied, regarding the fitness of this product for every specific experimental setup.

Technical Support: The protocols provided are for reference purposes. Unsure if this reagent suits your experiment? [[Contact our Ph.D. Support Team for a compatibility check](#)]

Need Industrial/Bulk Grade? [Request Custom Synthesis Quote](#)

BenchChem

Our mission is to be the trusted global source of essential and advanced chemicals, empowering scientists and researchers to drive progress in science and industry.

Contact

Address: 3281 E Guasti Rd

Ontario, CA 91761, United States

Phone: (601) 213-4426

Email: info@benchchem.com