

In Vitro Effects of Thymosin Alpha 1 on T-Cells: A Technical Guide

Author: BenchChem Technical Support Team. **Date:** December 2025

Compound of Interest

Compound Name: TAI-1

Cat. No.: B15623156

[Get Quote](#)

For Researchers, Scientists, and Drug Development Professionals

Introduction

Thymosin Alpha 1 ($T\alpha 1$), a 28-amino acid peptide originally isolated from the thymus, is a well-documented biological response modifier with significant immunomodulatory properties.^{[1][2]} It plays a crucial role in the maturation, differentiation, and function of T-cells, making it a subject of intense research for its therapeutic potential in various pathological conditions, including immunodeficiencies, malignancies, and infectious diseases.^{[1][2][3]} This technical guide provides an in-depth overview of the in vitro effects of $T\alpha 1$ on T-cells, focusing on quantitative data, detailed experimental protocols, and the underlying signaling pathways.

Quantitative Effects of Thymosin Alpha 1 on T-Cell Subpopulations

In vitro studies have demonstrated that $T\alpha 1$ can modulate the balance of various T-cell subsets. The following table summarizes the quantitative changes observed in peripheral blood mononuclear cell (PBMC) cultures treated with $T\alpha 1$.

T-Cell Subset	Treatment Condition	Fold Change / % Change	Reference
CD4+CD25+Foxp3+ (Tregs)	PBMCs from gastric cancer patients + Tα1 (50 µg/mL)	Increased from 1.68 ± 0.697% to 2.19 ± 0.795%	[1][4]
Activated CD4+ T-cells	Healthy donor immune cells + Tα1 (3 µM) for 48 hours	140% proliferation	[2]
Resting CD4+ T-cells	Healthy donor immune cells + Tα1 (up to 3 µM) for 48 hours	No significant proliferative effect	[2]
Activated CD8+ T-cells	Healthy donor immune cells + Tα1 (up to 3 µM) for 48 hours	No significant proliferative effect	[2]
Resting CD8+ T-cells	Healthy donor immune cells + Tα1 (up to 3 µM) for 48 hours	No significant proliferative effect	[2]

Quantitative Effects of Thymosin Alpha 1 on T-Cell Cytokine Production

Tα1 has been shown to significantly influence the cytokine secretion profile of T-cells and other immune cells within PBMC cultures. This modulation is crucial for directing the immune response towards a Th1 (cell-mediated) or Th2 (humoral) phenotype.

Cytokine	Cell Source	Treatment Condition	Fold Change / % Change	Reference
IL-1 β	PBMCs from gastric cancer patients	T α 1 (1 μ g/mL)	178% increase in secretion	[1]
TNF- α	PBMCs from gastric cancer patients	T α 1 (1 μ g/mL)	>500% increase in secretion	[1]
TNF- α	PBMCs from healthy donors	T α 1	Decreased levels	[1]
IL-6	PBMCs from healthy donors	T α 1 (10 μ g/mL)	>140% increase in secretion	[4]
IL-17A	PBMCs from healthy donors	T α 1 (10 μ g/mL) for 72 hours	Decreased secretion	[1]
IL-2	PBMCs from chronic hepatitis C patients	T α 1	Significant increase in production	[5]
IL-4	PBMCs from chronic hepatitis C patients	T α 1	Decrease in production	[5]
IL-10	PBMCs from chronic hepatitis C patients	T α 1	Decrease in production	[5]

Experimental Protocols

This section provides detailed methodologies for key in vitro assays used to evaluate the effects of T α 1 on T-cells.

T-Cell Proliferation Assay (CFSE-based)

This protocol outlines a method to assess T-cell proliferation using the dye dilution method with Carboxyfluorescein succinimidyl ester (CFSE).

Materials:

- Peripheral Blood Mononuclear Cells (PBMCs)
- RPMI-1640 medium with 10% Fetal Bovine Serum (FBS), L-glutamine, penicillin, and streptomycin
- Thymosin Alpha 1 (Tα1)
- CFSE dye
- Phosphate Buffered Saline (PBS)
- FACS buffer (PBS with 2% FBS)
- Flow cytometer

Procedure:

- PBMC Isolation: Isolate PBMCs from whole blood using Ficoll-Paque density gradient centrifugation.
- CFSE Staining:
 - Resuspend 10-20 x 10⁶ PBMCs in pre-warmed PBS at a concentration of 1 x 10⁶ cells/mL.
 - Add CFSE to a final concentration of 0.05 μM.[\[6\]](#)
 - Incubate for 5 minutes at 37°C, protected from light.[\[6\]](#)
 - Quench the staining by adding 5 volumes of ice-cold complete culture medium.
 - Wash the cells twice with complete culture medium.
- Cell Culture and Tα1 Treatment:
 - Resuspend CFSE-labeled PBMCs in complete RPMI-1640 medium.

- Seed 2×10^5 cells per well in a 96-well round-bottom plate.
- Add T α 1 at desired concentrations (e.g., 30 nM, 300 nM, 3 μ M).[2] Include an untreated control.
- Incubate for 4-7 days at 37°C in a 5% CO₂ incubator.[6][7]
- Flow Cytometry Analysis:
 - Harvest the cells and wash with FACS buffer.
 - Stain with fluorescently labeled antibodies against T-cell surface markers (e.g., CD3, CD4, CD8).
 - Acquire data on a flow cytometer. Proliferation is measured by the successive halving of CFSE fluorescence intensity in daughter cells.

Workflow for CFSE-based T-Cell Proliferation Assay

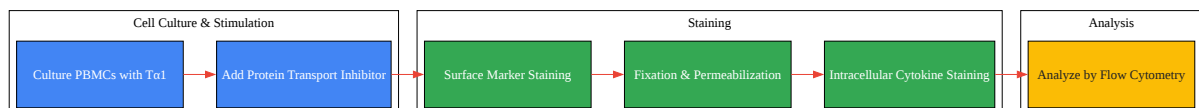
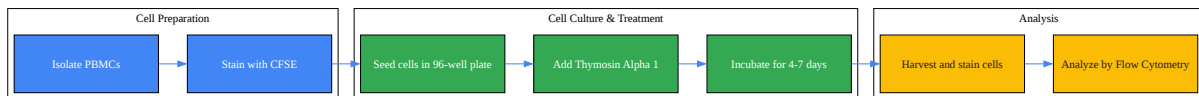

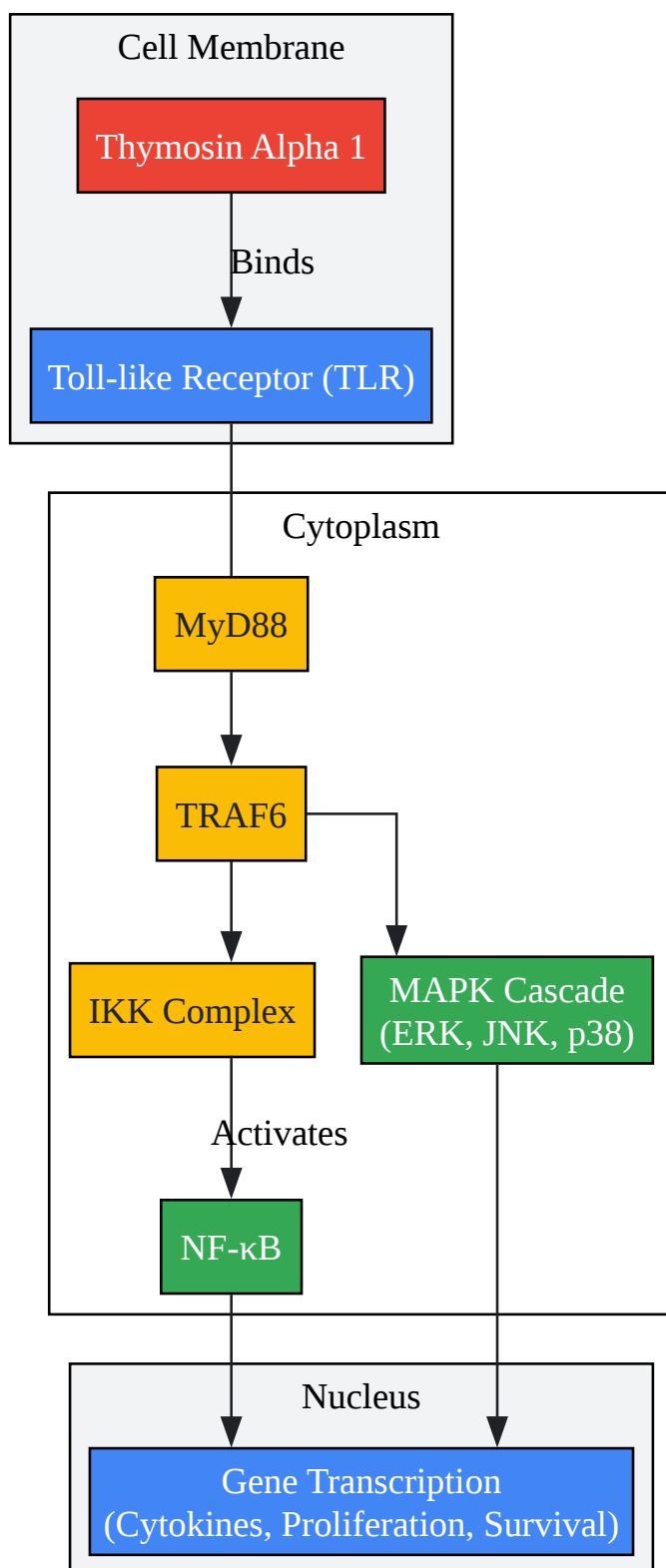

[Click to download full resolution via product page](#)

Need Custom Synthesis?

BenchChem offers custom synthesis for rare earth carbides and specific isotopic labeling.

Email: info@benchchem.com or [Request Quote Online](#).

References

- 1. Effect of thymosin alpha-1 on subpopulations of Th1, Th2, Th17, and regulatory T cells (Tregs) in vitro - PMC [pmc.ncbi.nlm.nih.gov]
- 2. The Immunomodulatory Activity of Thymosin Alpha 1 on Tumor Cell Lines and Distinct Immune Cell Subsets - PMC [pmc.ncbi.nlm.nih.gov]
- 3. Thymosin alpha 1: A comprehensive review of the literature - PMC [pmc.ncbi.nlm.nih.gov]
- 4. researchgate.net [researchgate.net]
- 5. In vitro effect of thymosin-alpha1 and interferon-alpha on Th1 and Th2 cytokine synthesis in patients with chronic hepatitis C - PubMed [pubmed.ncbi.nlm.nih.gov]
- 6. Frontiers | Optimization of a Method to Detect Autoantigen-Specific T-Cell Responses in Type 1 Diabetes [frontiersin.org]
- 7. mucosalimmunology.ch [mucosalimmunology.ch]
- To cite this document: BenchChem. [In Vitro Effects of Thymosin Alpha 1 on T-Cells: A Technical Guide]. BenchChem, [2025]. [Online PDF]. Available at: [https://www.benchchem.com/product/b15623156#in-vitro-studies-of-thymosin-alpha-1-effects-on-t-cells]

Disclaimer & Data Validity:

The information provided in this document is for Research Use Only (RUO) and is strictly not intended for diagnostic or therapeutic procedures. While BenchChem strives to provide accurate protocols, we make no warranties, express or implied, regarding the fitness of this product for every specific experimental setup.

Technical Support: The protocols provided are for reference purposes. Unsure if this reagent suits your experiment? [[Contact our Ph.D. Support Team for a compatibility check](#)]

Need Industrial/Bulk Grade? [Request Custom Synthesis Quote](#)

BenchChem

Our mission is to be the trusted global source of essential and advanced chemicals, empowering scientists and researchers to drive progress in science and industry.

Contact

Address: 3281 E Guasti Rd

Ontario, CA 91761, United States

Phone: (601) 213-4426

Email: info@benchchem.com