

In-Depth Technical Guide: Discovery and Synthesis of MRT68601 Hydrochloride

Author: BenchChem Technical Support Team. **Date:** December 2025

Compound of Interest

Compound Name: MRT 68601 hydrochloride

Cat. No.: B609330

[Get Quote](#)

For Researchers, Scientists, and Drug Development Professionals

Abstract

MRT68601 hydrochloride is a potent and selective inhibitor of TANK-binding kinase 1 (TBK1) and I κ B kinase ϵ (IKK ϵ), key regulators of innate immunity and cellular inflammatory responses. It also demonstrates significant inhibitory activity against Unc-51 like autophagy activating kinase 1 (ULK1) and ULK2, crucial components of the autophagy pathway. This dual activity makes MRT68601 a valuable tool for investigating the interplay between inflammation, autophagy, and diseases such as cancer. This technical guide provides a comprehensive overview of the discovery, synthesis, and biological characterization of MRT68601 hydrochloride, including detailed experimental protocols and quantitative data to support its use in research and drug development.

Discovery and Rationale

MRT68601 was identified through a focused discovery program aimed at developing small molecule inhibitors of TBK1 and IKK ϵ . These non-canonical IKK kinases play a pivotal role in the activation of interferon regulatory factors (IRFs) and NF- κ B signaling pathways, which are often dysregulated in inflammatory diseases and various cancers. The rationale for targeting these kinases is to modulate the production of pro-inflammatory cytokines and to interfere with the survival signals that are crucial for tumor cell proliferation. Further characterization of MRT68601 revealed its potent inhibitory effect on ULK1 and ULK2, positioning it as a valuable

chemical probe to explore the therapeutic potential of targeting the autophagy initiation complex.

Chemical Synthesis of MRT68601 Hydrochloride

The synthesis of MRT68601 hydrochloride is a multi-step process. A detailed, step-by-step protocol is outlined below, based on established synthetic chemistry principles.

Experimental Protocol: Synthesis of MRT68601 Hydrochloride

Step 1: Synthesis of Intermediate 1 (2-chloro-N-(4-methoxyphenyl)pyrimidin-4-amine)

- To a solution of 2,4-dichloropyrimidine in a suitable solvent such as isopropanol, add p-anisidine.
- The reaction mixture is stirred at reflux for a specified period, typically 12-24 hours, while monitoring the reaction progress by thin-layer chromatography (TLC) or liquid chromatography-mass spectrometry (LC-MS).
- Upon completion, the reaction mixture is cooled to room temperature, and the resulting precipitate is collected by filtration.
- The solid is washed with a cold solvent, such as diethyl ether, and dried under vacuum to yield the desired intermediate.

Step 2: Synthesis of Intermediate 2 (N2-(4-methoxyphenyl)-N4-(3-((tert-butoxycarbonyl)amino)propyl)pyrimidine-2,4-diamine)

- Intermediate 1 is reacted with tert-butyl (3-aminopropyl)carbamate in the presence of a non-nucleophilic base, such as diisopropylethylamine (DIPEA), in a polar aprotic solvent like N,N-dimethylformamide (DMF).
- The reaction is heated to an elevated temperature, for instance, 80-100 °C, for several hours until the starting material is consumed.

- The reaction mixture is then cooled, diluted with water, and extracted with an organic solvent like ethyl acetate.
- The combined organic layers are washed with brine, dried over anhydrous sodium sulfate, filtered, and concentrated under reduced pressure. The crude product is purified by column chromatography on silica gel.

Step 3: Synthesis of MRT68601 (Free Base)

- The Boc-protecting group of Intermediate 2 is removed under acidic conditions, for example, by treating with trifluoroacetic acid (TFA) in dichloromethane (DCM) or with hydrochloric acid in dioxane.
- The reaction is stirred at room temperature for 1-2 hours.
- The solvent is removed under reduced pressure, and the resulting amine is coupled with a suitable acylating agent, such as an activated ester or an acyl chloride of the desired side chain, in the presence of a coupling agent like HATU or HBTU and a base (e.g., DIPEA) in DMF.
- The reaction progress is monitored by LC-MS. Upon completion, the reaction mixture is worked up by dilution with water and extraction with an organic solvent.
- The crude product is purified by preparative high-performance liquid chromatography (HPLC) to yield the pure free base of MRT68601.

Step 4: Formation of MRT68601 Hydrochloride Salt

- The purified free base of MRT68601 is dissolved in a minimal amount of a suitable solvent, such as methanol or ethyl acetate.
- A solution of hydrochloric acid in a solvent like diethyl ether or dioxane is added dropwise with stirring.
- The resulting precipitate, MRT68601 hydrochloride, is collected by filtration, washed with a non-polar solvent (e.g., diethyl ether), and dried under vacuum.

Biological Activity and Mechanism of Action

MRT68601 hydrochloride exerts its biological effects through the potent and selective inhibition of key kinases involved in inflammation and autophagy.

Kinase Inhibitory Profile

The kinase selectivity of MRT68601 was extensively profiled against a panel of kinases. The compound demonstrates high potency against its primary targets, TBK1 and IKK ϵ , with significant activity also observed against ULK1 and ULK2.

Kinase Target	IC50 (nM)
TBK1	6
IKK ϵ	Data not available
ULK1	Data not available
ULK2	Data not available
MARK3	>10-fold selective over TBK1

Note: A comprehensive kinase selectivity profile with specific IC50 values for IKK ϵ , ULK1, and ULK2 is not publicly available in the reviewed literature.

Experimental Protocol: Kinase Selectivity Profiling

Kinase selectivity profiling was performed at the Protein Phosphorylation Unit, University of Dundee. A typical kinase inhibition assay involves the following steps:

- **Reagents and Buffers:** Prepare assay buffer containing a buffer salt (e.g., HEPES), MgCl₂, ATP, and a specific peptide substrate for the kinase of interest.
- **Enzyme and Inhibitor Preparation:** Recombinant human kinases are used. MRT68601 hydrochloride is dissolved in dimethyl sulfoxide (DMSO) to create a stock solution, which is then serially diluted to the desired concentrations.

- Assay Procedure:
 - The kinase reaction is initiated by mixing the kinase, the peptide substrate, and the test compound (MRT68601) in the assay buffer.
 - The reaction is started by the addition of [γ -³²P]ATP or [γ -³³P]ATP.
 - The reaction mixture is incubated at a controlled temperature (e.g., 30 °C) for a specific time.
 - The reaction is stopped by spotting the mixture onto phosphocellulose paper or by adding a stop solution.
 - The filter paper is washed to remove unincorporated radiolabeled ATP.
 - The amount of radioactivity incorporated into the peptide substrate is quantified using a scintillation counter.
- Data Analysis: The percentage of kinase activity is calculated relative to a DMSO control. IC₅₀ values are determined by plotting the percentage of inhibition against the logarithm of the inhibitor concentration and fitting the data to a sigmoidal dose-response curve.

Inhibition of Autophagy

MRT68601 has been shown to inhibit autophagosome formation in lung cancer cells.^[1] This is consistent with its inhibitory activity against ULK1 and ULK2, which are essential for the initiation of the autophagy process.

Experimental Protocol: Autophagy Flux Assay in A549 Cells

The effect of MRT68601 on autophagy can be assessed using an autophagy flux assay, which measures the degradation of autophagy-related proteins like LC3-II.

- Cell Culture: A549 non-small cell lung cancer cells are cultured in a suitable medium, such as DMEM, supplemented with 10% fetal bovine serum.

- Treatment: Cells are treated with various concentrations of MRT68601 hydrochloride or a vehicle control (DMSO) for a specified period (e.g., 24 hours). In some conditions, a lysosomal inhibitor such as chloroquine (CQ) or bafilomycin A1 is added for the last few hours of the treatment to block the degradation of autophagosomes.
- Cell Lysis and Western Blotting:
 - Cells are harvested and lysed in a radioimmunoprecipitation assay (RIPA) buffer containing protease and phosphatase inhibitors.
 - Protein concentration is determined using a BCA assay.
 - Equal amounts of protein are separated by SDS-PAGE and transferred to a PVDF membrane.
 - The membrane is blocked and then incubated with primary antibodies against LC3 and a loading control (e.g., β -actin).
 - After washing, the membrane is incubated with a horseradish peroxidase (HRP)-conjugated secondary antibody.
 - The protein bands are visualized using an enhanced chemiluminescence (ECL) detection system.
- Data Analysis: The levels of LC3-I and LC3-II are quantified by densitometry. An increase in the LC3-II/LC3-I ratio in the presence of a lysosomal inhibitor compared to the inhibitor alone indicates an increase in autophagic flux. Conversely, a decrease in the accumulation of LC3-II in the presence of a lysosomal inhibitor and MRT68601 suggests an inhibition of autophagic flux.

Signaling Pathways and Workflows

Signaling Pathway of TBK1/IKK ϵ Inhibition

The inhibition of TBK1 and IKK ϵ by MRT68601 disrupts the downstream signaling cascade that leads to the activation of IRF3 and NF- κ B. This, in turn, reduces the expression of type I interferons and other pro-inflammatory genes.

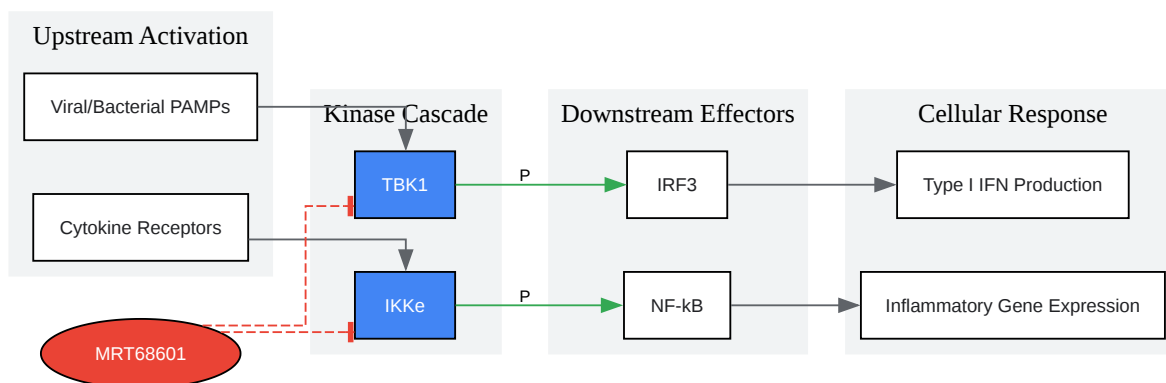

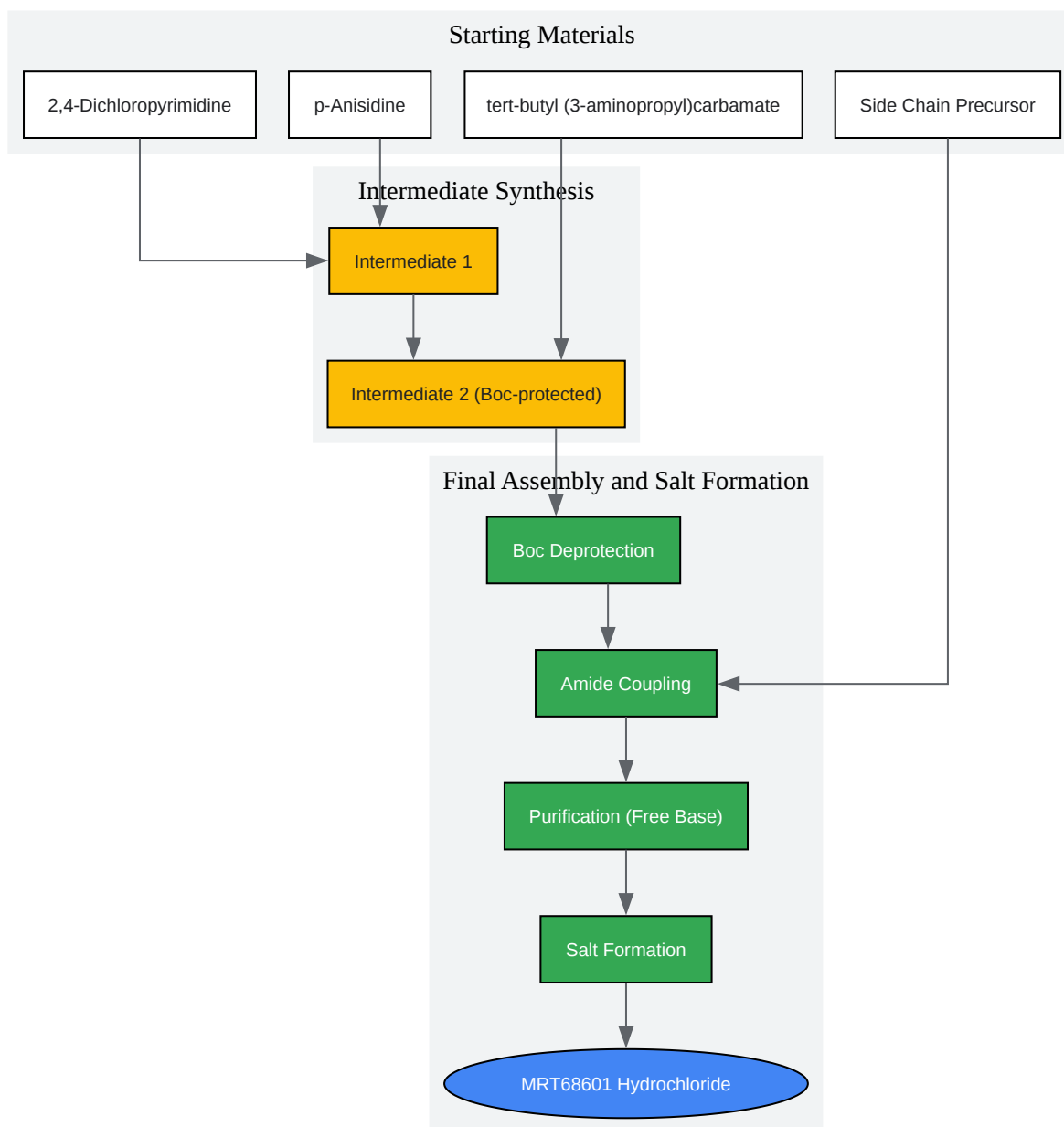

[Click to download full resolution via product page](#)

Need Custom Synthesis?

BenchChem offers custom synthesis for rare earth carbides and specific isotopic labeling.

Email: info@benchchem.com or [Request Quote Online](#).

References

- 1. Smooth Muscle-Like Tissue Constructs with Circumferentially Oriented Cells Formed by the Cell Fiber Technology | PLOS One [journals.plos.org]
- To cite this document: BenchChem. [In-Depth Technical Guide: Discovery and Synthesis of MRT68601 Hydrochloride]. BenchChem, [2025]. [Online PDF]. Available at: [https://www.benchchem.com/product/b609330#discovery-and-synthesis-of-mrt-68601-hydrochloride]

Disclaimer & Data Validity:

The information provided in this document is for Research Use Only (RUO) and is strictly not intended for diagnostic or therapeutic procedures. While BenchChem strives to provide accurate protocols, we make no warranties, express or implied, regarding the fitness of this product for every specific experimental setup.

Technical Support: The protocols provided are for reference purposes. Unsure if this reagent suits your experiment? [[Contact our Ph.D. Support Team for a compatibility check](#)]

Need Industrial/Bulk Grade? [Request Custom Synthesis Quote](#)

BenchChem

Our mission is to be the trusted global source of essential and advanced chemicals, empowering scientists and researchers to drive progress in science and industry.

Contact

Address: 3281 E Guasti Rd
Ontario, CA 91761, United States
Phone: (601) 213-4426
Email: info@benchchem.com