

# In-Depth Pharmacological Profile of WAY-361789: A Technical Guide

**Author:** BenchChem Technical Support Team. **Date:** December 2025

## Compound of Interest

Compound Name: WAY-361789

Cat. No.: B1683282

[Get Quote](#)

For Researchers, Scientists, and Drug Development Professionals

## Abstract

**WAY-361789**, also known as SEN15924, is a potent and selective agonist of the  $\alpha 7$  nicotinic acetylcholine receptor ( $\alpha 7$  nAChR).[1][2] As a promising therapeutic candidate for cognitive deficits associated with neurological and psychiatric disorders such as Alzheimer's disease and schizophrenia, a comprehensive understanding of its pharmacological profile is essential. This technical guide provides an in-depth overview of the in vitro and in vivo pharmacology of **WAY-361789**, including its binding affinity, functional activity, selectivity, pharmacokinetic properties, and efficacy in preclinical models of cognition. Detailed experimental protocols and visualizations of key pathways and workflows are presented to support further research and development efforts.

## Introduction

The  $\alpha 7$  nicotinic acetylcholine receptor, a ligand-gated ion channel highly expressed in key brain regions like the hippocampus and cortex, plays a crucial role in modulating cognitive functions, including attention, learning, and memory. Agonism of the  $\alpha 7$  nAChR is a well-validated therapeutic strategy for enhancing cognitive function. **WAY-361789** has emerged as a significant compound in this class due to its potent agonistic activity, selectivity, and oral bioavailability.[1] This document serves as a comprehensive technical resource, consolidating the pharmacological data and methodologies associated with the characterization of **WAY-361789**.

## In Vitro Pharmacology

### Binding Affinity and Selectivity

The binding affinity of **WAY-361789** to the human  $\alpha 7$  nAChR and its selectivity against a panel of other neurotransmitter receptors and ion channels have been characterized through radioligand binding assays.

Table 1: Binding Affinity (Ki) of **WAY-361789** at Human  $\alpha 7$  nAChR and Selectivity Panel

Receptor/Target	Ki (nM)
$\alpha 7$ nAChR	180
$\alpha 1\beta 1\gamma\delta$ nAChR	>10,000
$\alpha 3\beta 4$ nAChR	>10,000
5-HT3 Receptor	>10,000
hERG	>30,000

Data extracted from Zanaletti R, et al. J Med Chem. 2012;55(10):4806-23.

### Functional Activity

**WAY-361789** acts as a full agonist at the human  $\alpha 7$  nAChR. Its functional potency has been determined using a calcium flux assay in a cell line stably expressing the human  $\alpha 7$  nAChR.

Table 2: Functional Potency (EC50) of **WAY-361789** at Human  $\alpha 7$  nAChR

Assay	Cell Line	EC50 ( $\mu$ M)
Calcium Flux	SH-EP1-h $\alpha 7$	0.18

Data from MedChemExpress product information, citing Zanaletti R, et al. J Med Chem. 2012;55(10):4806-23.[2]

## In Vivo Pharmacology

## Pharmacokinetics

The pharmacokinetic profile of **WAY-361789** has been evaluated in rats following oral (p.o.) administration.

Table 3: Pharmacokinetic Parameters of **WAY-361789** in Rats (10 mg/kg, p.o.)

Parameter	Value
C <sub>max</sub> (ng/mL)	530
T <sub>max</sub> (h)	0.5
Half-life (t <sub>1/2</sub> ) (h)	2.1
AUC (ng·h/mL)	1250
Oral Bioavailability (%)	35

Data extracted from Zanaletti R, et al. J Med Chem. 2012;55(10):4806-23.

## Efficacy in Cognitive Models

**WAY-361789** has demonstrated efficacy in rodent models of cognitive impairment, specifically the Novel Object Recognition (NOR) test and an auditory sensory gating paradigm.

**WAY-361789** was shown to reverse a scopolamine-induced deficit in novel object recognition in rats, indicating a pro-cognitive effect.

In a model relevant to schizophrenia, **WAY-361789** normalized the P20/N40 auditory evoked potential gating deficit induced by amphetamine in rats.

## Signaling Pathways

Activation of the  $\alpha 7$  nAChR by **WAY-361789** initiates a cascade of intracellular signaling events. As a ligand-gated ion channel, its activation leads to a rapid influx of cations, primarily Ca<sup>2+</sup>. This increase in intracellular calcium can subsequently modulate various downstream signaling pathways implicated in synaptic plasticity and cell survival.

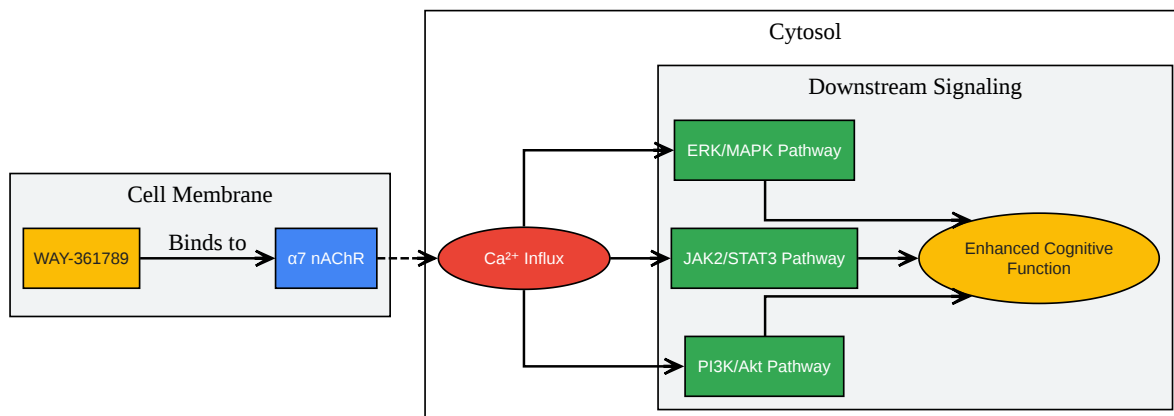

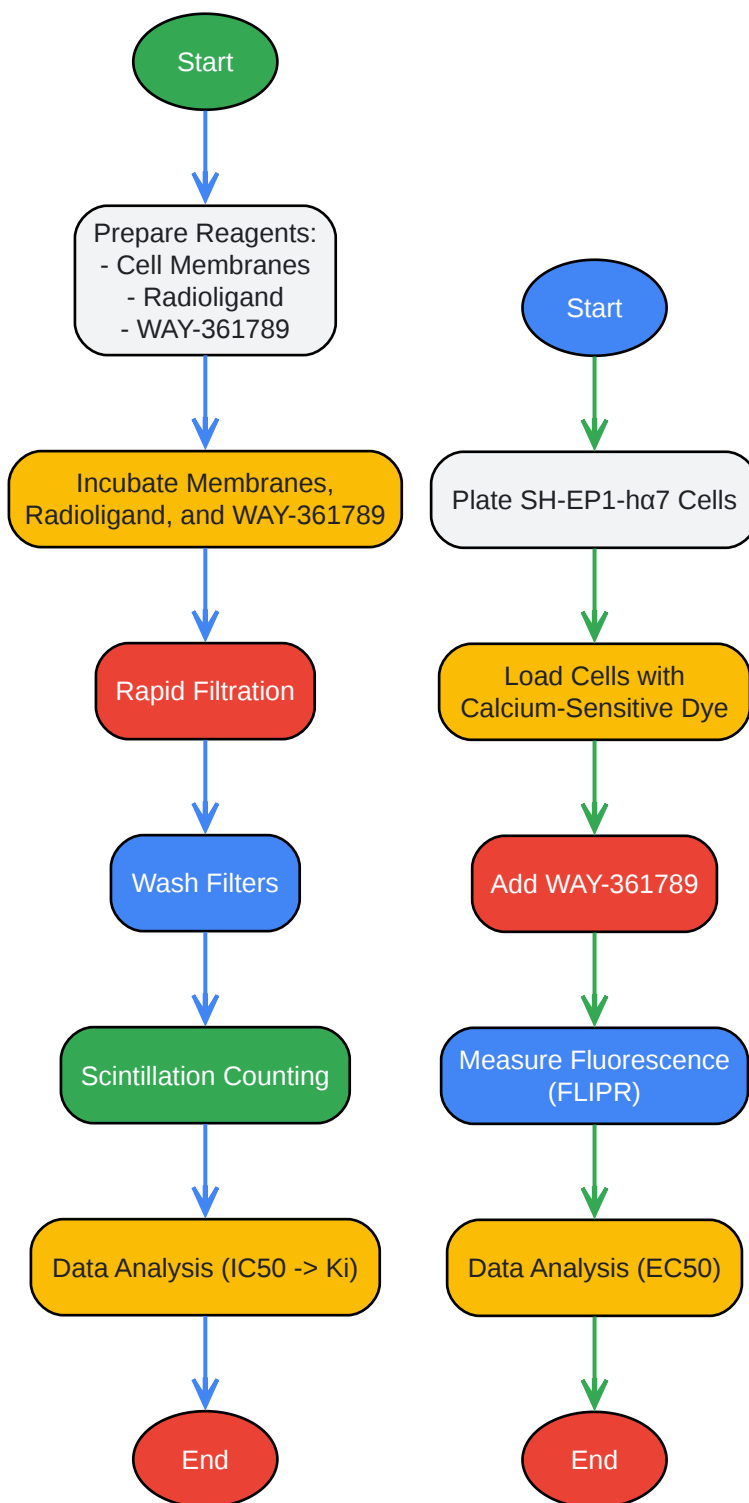

[Click to download full resolution via product page](#)

### Need Custom Synthesis?

BenchChem offers custom synthesis for rare earth carbides and specific isotopic labeling.

Email: [info@benchchem.com](mailto:info@benchchem.com) or [Request Quote Online](#).

## References

- 1. Discovery of a novel alpha-7 nicotinic acetylcholine receptor agonist series and characterization of the potent, selective, and orally efficacious agonist 5-(4-acetyl[1,4]diazepan-1-yl)pentanoic acid [5-(4-methoxyphenyl)-1H-pyrazol-3-yl] amide (SEN15924, WAY-361789) - PubMed [[pubmed.ncbi.nlm.nih.gov](https://pubmed.ncbi.nlm.nih.gov)]
- 2. [medchemexpress.com](https://www.medchemexpress.com) [[medchemexpress.com](https://www.medchemexpress.com)]
- To cite this document: BenchChem. [In-Depth Pharmacological Profile of WAY-361789: A Technical Guide]. BenchChem, [2025]. [Online PDF]. Available at: [<https://www.benchchem.com/product/b1683282#pharmacological-profile-of-way-361789>]

### Disclaimer & Data Validity:

The information provided in this document is for Research Use Only (RUO) and is strictly not intended for diagnostic or therapeutic procedures. While BenchChem strives to provide accurate protocols, we make no warranties, express or implied, regarding the fitness of this product for every specific experimental setup.

**Technical Support:** The protocols provided are for reference purposes. Unsure if this reagent suits your experiment? [[Contact our Ph.D. Support Team for a compatibility check](#)]

**Need Industrial/Bulk Grade?** [Request Custom Synthesis Quote](#)

# BenchChem

Our mission is to be the trusted global source of essential and advanced chemicals, empowering scientists and researchers to drive progress in science and industry.

## Contact

Address: 3281 E Guasti Rd

Ontario, CA 91761, United States

Phone: (601) 213-4426

Email: [info@benchchem.com](mailto:info@benchchem.com)