

# Illuminating the Mechanism of ML348: A Comparative Guide to Biochemical Confirmation

**Author:** BenchChem Technical Support Team. **Date:** December 2025

## Compound of Interest

Compound Name: ML348

Cat. No.: B1676650

[Get Quote](#)

For researchers, scientists, and drug development professionals, rigorously confirming a compound's mechanism of action is a cornerstone of preclinical research. This guide provides a detailed comparison of biochemical assays used to validate the inhibitory action of **ML348** on its primary target, Lysophospholipase 1 (LYPLA1), also known as Acyl-protein thioesterase 1 (APT1). We will explore the experimental data supporting its selectivity and compare its performance with alternative inhibitors.

**ML348** is a potent and selective reversible inhibitor of LYPLA1, an enzyme responsible for depalmitoylating proteins, a crucial post-translational modification that governs protein trafficking, localization, and signaling.[1] Dysregulation of protein palmitoylation is implicated in various diseases, including cancer and neurological disorders, making LYPLA1 an attractive therapeutic target.[2][3][4] This guide will delve into the key biochemical assays that have been instrumental in characterizing **ML348**'s mechanism of action.

## Comparative Performance of LYPLA1/APT1 Inhibitors

The following table summarizes the quantitative data for **ML348** and compares it with ML349, a selective inhibitor for the related enzyme LYPLA2 (APT2), and Palmostatin B, a dual inhibitor of both APT1 and APT2. This data is crucial for understanding the selectivity and potency of these compounds.

Compound	Target(s)	IC50 (nM)	Ki (nM)	Assay Type	Reference
ML348	LYPLA1 (APT1)	230	200-300	Fluorogenic Substrate Assay	[1][5]
ML349	LYPLA2 (APT2)	-	200-300	Fluorogenic Substrate Assay	[5][6]
Palmostatin B	LYPLA1 & LYPLA2 (APT1 & APT2)	-	-	Cellular Assays	[2][3]

## Key Biochemical Assays for Mechanism Confirmation

A multi-faceted approach employing a variety of biochemical assays is essential to unequivocally confirm the mechanism of action of an inhibitor like **ML348**. Below are detailed descriptions of the pivotal experiments used.

### Activity-Based Protein Profiling (ABPP)

Activity-Based Protein Profiling (ABPP) is a powerful chemical proteomic technique used to assess the potency and selectivity of enzyme inhibitors within complex proteomes. For **ML348**, both gel-based and advanced mass spectrometry-based (SILAC) ABPP methods have been employed.[1]

#### Experimental Protocol: Gel-Based Competitive ABPP

- Proteome Preparation: A complex proteome, such as a mouse brain lysate, is prepared.
- Inhibitor Incubation: The proteome is incubated with varying concentrations of the test compound (e.g., **ML348**).
- Probe Labeling: A broad-spectrum, active site-directed probe for serine hydrolases, such as a fluorophosphonate-rhodamine (FP-Rh) probe, is added. This probe covalently binds to the

active site of serine hydrolases that are not occupied by the inhibitor.

- **SDS-PAGE and Fluorescence Scanning:** The proteome is separated by SDS-PAGE, and the gel is scanned for fluorescence. A decrease in fluorescence intensity for a specific protein band in the presence of the inhibitor indicates target engagement.
- **Data Analysis:** The reduction in fluorescence is quantified to determine the inhibitor's potency (e.g., IC<sub>50</sub>).

## Fluorogenic Substrate-Based Assays

These assays directly measure the enzymatic activity of LYPLA1 and are crucial for determining kinetic parameters of inhibition, such as IC<sub>50</sub> and K<sub>i</sub> values. A commonly used substrate is resorufin acetate, which becomes fluorescent upon hydrolysis by the enzyme.<sup>[1][5]</sup>

### Experimental Protocol: Fluorogenic Substrate Assay for LYPLA1 Inhibition

- **Reagents:** Purified recombinant human LYPLA1, resorufin acetate (substrate), and the test inhibitor (**ML348**) are prepared in an appropriate assay buffer (e.g., DPBS, pH 6.5).
- **Assay Setup:** The assay is typically performed in a 96- or 384-well plate format. A solution of the inhibitor at various concentrations is pre-incubated with the enzyme.
- **Reaction Initiation:** The enzymatic reaction is initiated by the addition of the resorufin acetate substrate.
- **Fluorescence Monitoring:** The increase in fluorescence over time, corresponding to the hydrolysis of the substrate, is monitored using a fluorescence plate reader.
- **Data Analysis:** The initial reaction velocities are calculated and plotted against the inhibitor concentration to determine the IC<sub>50</sub> value. The Cheng-Prusoff equation can then be used to calculate the K<sub>i</sub> value.<sup>[1]</sup>

## Target Engagement Confirmation Assays

To confirm that **ML348** directly binds to and stabilizes its target protein, thermal shift assays and competition binding assays are employed.

- Differential Scanning Fluorimetry (DSF) / Thermal Shift Assay: This technique measures the thermal stability of a protein.[5] Ligand binding typically increases the melting temperature ( $T_m$ ) of the protein. An increase in the  $T_m$  of LYPLA1 in the presence of **ML348** provides strong evidence of direct binding.[5]
- BODIPY-FL-C16 Competition Assay: This assay utilizes a fluorescently labeled lipid substrate analog (BODIPY-FL-C16) that binds to the acyl-binding pocket of LYPLA1.[5] A dose-dependent reduction in the fluorescence signal upon the addition of **ML348** demonstrates that the inhibitor competes for and occupies the same binding site.[5]

## Visualizing the Mechanism and Experimental Workflow

To further clarify the concepts discussed, the following diagrams illustrate the signaling pathway affected by **ML348** and the general workflow of a competitive biochemical assay.

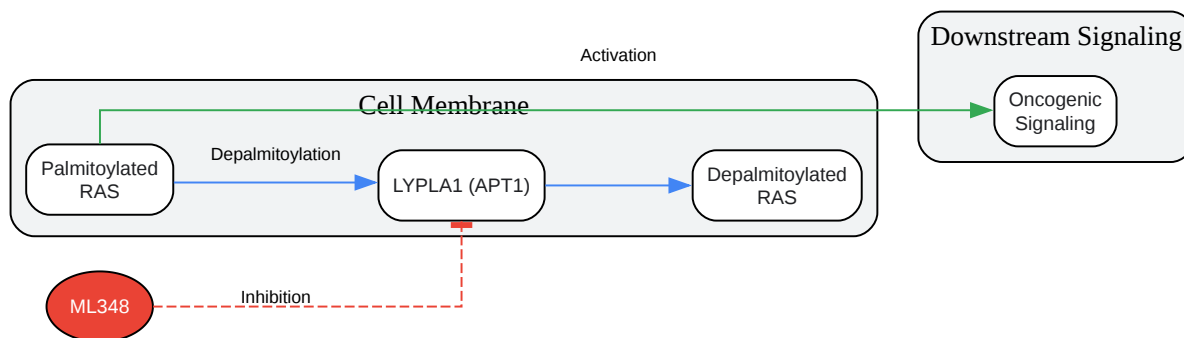

[Click to download full resolution via product page](#)

Caption: Mechanism of **ML348** action on RAS signaling.

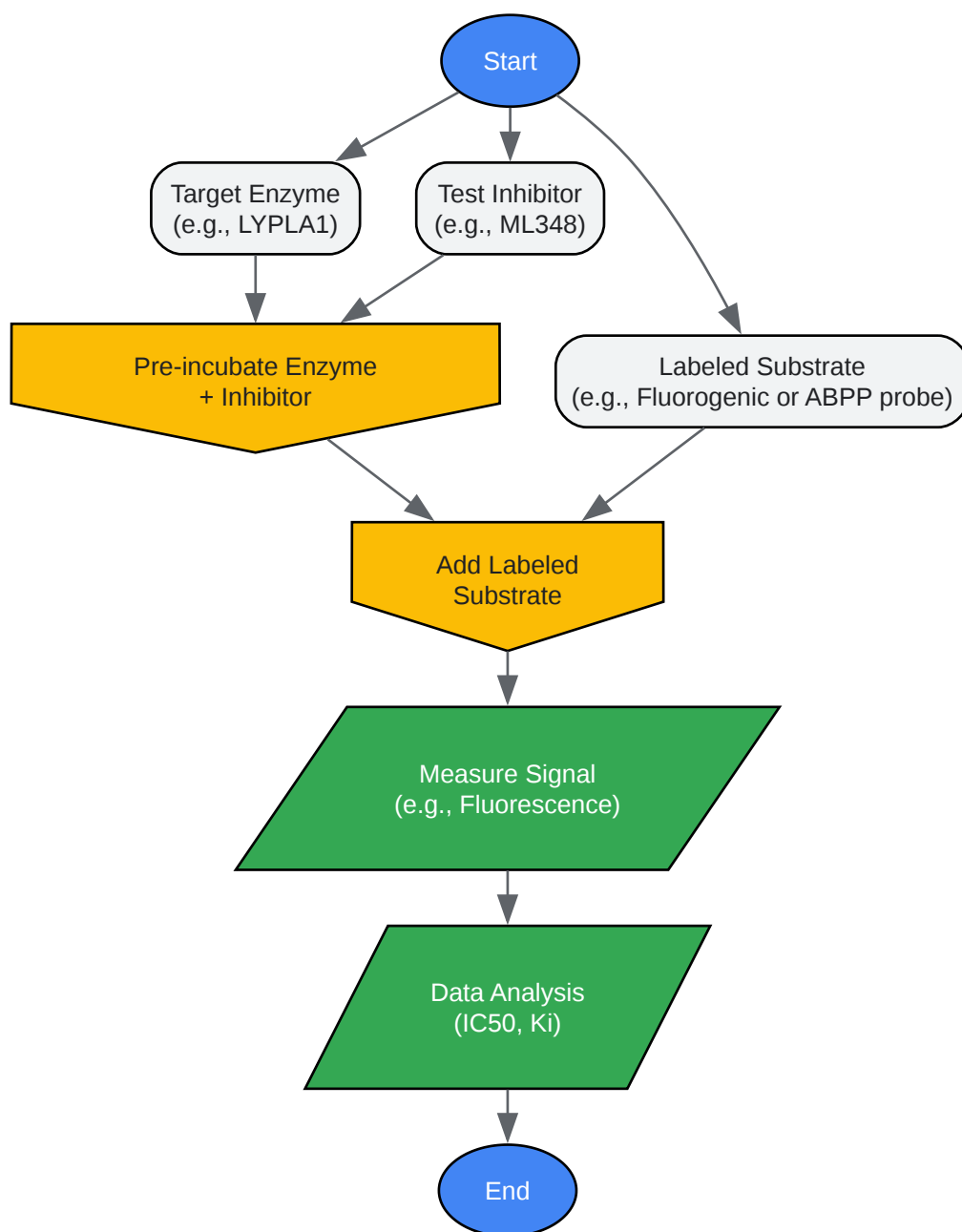

[Click to download full resolution via product page](#)

Caption: General workflow of a competitive biochemical assay.

## Conclusion

The biochemical assays outlined in this guide provide a robust framework for confirming the mechanism of action of **ML348** as a selective inhibitor of LYPLA1. By employing a combination of activity-based protein profiling, direct enzymatic assays, and target engagement studies,

researchers can confidently validate the on-target effects of this and other small molecule inhibitors. This rigorous approach is indispensable for the successful progression of drug discovery and development programs.

### Need Custom Synthesis?

BenchChem offers custom synthesis for rare earth carbides and specific isotopic labeling.

Email: [info@benchchem.com](mailto:info@benchchem.com) or [Request Quote Online](#).

## References

- 1. Characterization of a Selective, Reversible Inhibitor of Lysophospholipase 1 (LYPLA1) - Probe Reports from the NIH Molecular Libraries Program - NCBI Bookshelf [[ncbi.nlm.nih.gov](https://pubmed.ncbi.nlm.nih.gov/)]
- 2. Acyl protein thioesterase 1 and 2 (APT-1, APT-2) inhibitors palmostatin B, ML348 and ML349 have different effects on NRAS mutant melanoma cells - PubMed [[pubmed.ncbi.nlm.nih.gov](https://pubmed.ncbi.nlm.nih.gov/)]
- 3. Acyl protein thioesterase 1 and 2 (APT-1, APT-2) inhibitors palmostatin B, ML348 and ML349 have different effects on NRAS mutant melanoma cells - PMC [[pmc.ncbi.nlm.nih.gov](https://pubmed.ncbi.nlm.nih.gov/)]
- 4. Increasing brain palmitoylation rescues behavior and neuropathology in Huntington disease mice - PMC [[pmc.ncbi.nlm.nih.gov](https://pubmed.ncbi.nlm.nih.gov/)]
- 5. Molecular mechanism for isoform-selective inhibition of acyl protein thioesterases 1 and 2 (APT1 and APT2) - PMC [[pmc.ncbi.nlm.nih.gov](https://pubmed.ncbi.nlm.nih.gov/)]
- 6. Characterization of a Selective, Reversible Inhibitor of Lysophospholipase 2 (LYPLA2) - Probe Reports from the NIH Molecular Libraries Program - NCBI Bookshelf [[ncbi.nlm.nih.gov](https://pubmed.ncbi.nlm.nih.gov/)]
- To cite this document: BenchChem. [Illuminating the Mechanism of ML348: A Comparative Guide to Biochemical Confirmation]. BenchChem, [2025]. [Online PDF]. Available at: [<https://www.benchchem.com/product/b1676650#biochemical-assays-to-confirm-ml348-s-mechanism>]

---

### Disclaimer & Data Validity:

The information provided in this document is for Research Use Only (RUO) and is strictly not intended for diagnostic or therapeutic procedures. While BenchChem strives to provide

accurate protocols, we make no warranties, express or implied, regarding the fitness of this product for every specific experimental setup.

**Technical Support:** The protocols provided are for reference purposes. Unsure if this reagent suits your experiment? [[Contact our Ph.D. Support Team for a compatibility check](#)]

**Need Industrial/Bulk Grade?** [Request Custom Synthesis Quote](#)

## BenchChem

Our mission is to be the trusted global source of essential and advanced chemicals, empowering scientists and researchers to drive progress in science and industry.

### Contact

Address: 3281 E Guasti Rd

Ontario, CA 91761, United States

Phone: (601) 213-4426

Email: [info@benchchem.com](mailto:info@benchchem.com)