

How to control for Sumarotene photostability in experiments

Author: BenchChem Technical Support Team. **Date:** December 2025

Compound of Interest

Compound Name: Sumarotene

Cat. No.: B1637876

[Get Quote](#)

Technical Support Center: Sumarotene Photostability

This technical support center provides researchers, scientists, and drug development professionals with comprehensive guidance on controlling for **Sumarotene's** photostability in experiments. The information is presented in a question-and-answer format to directly address common issues.

Frequently Asked Questions (FAQs)

Q1: What is **Sumarotene** and why is its photostability a concern?

Sumarotene is a third-generation retinoid utilized as a topical agent for various dermatological applications, including the repair of photodamage and for its antikeratinization and antiproliferative properties[1]. Like many retinoids, **Sumarotene's** chemical structure may be susceptible to degradation upon exposure to light, which can potentially alter its efficacy and safety profile. Therefore, understanding and controlling its photostability is crucial during experimental design and formulation development. While third-generation retinoids are generally more photostable than first-generation retinoids, it is still a critical parameter to evaluate[2][3].

Q2: What are the typical degradation pathways for retinoids like **Sumarotene**?

While specific degradation pathways for **Sumarotene** are not extensively published, studies on other third-generation retinoids, such as tazarotene, suggest that photodegradation primarily involves oxidation of specific chemical moieties. For instance, in tazarotene, the 4,4-dimethyl-3,4-dihydro-2H-thiopyran moiety is susceptible to oxidation at the methyl groups and the sulfur atom[4][5]. Photoisomerization is another common degradation pathway for retinoids. It is plausible that **Sumarotene** could undergo similar degradation processes.

Q3: What are the initial signs of **Sumarotene** degradation in my experiment?

Visual signs of degradation can include a change in the color or clarity of your **Sumarotene** solution. However, the most reliable indicators are changes in the analytical profile. A decrease in the peak area of the parent **Sumarotene** compound and the appearance of new peaks corresponding to degradation products in your chromatogram (e.g., HPLC, UPLC) are definitive signs of degradation.

Q4: How can I minimize **Sumarotene** photodegradation during routine lab work?

To minimize photodegradation during daily experiments, the following precautions are recommended:

- Work in low-light conditions: Use amber-colored glassware or lab spaces with UV-filtered lighting.
- Protect solutions from light: Wrap containers with aluminum foil or use opaque storage vials.
- Prepare fresh solutions: Prepare **Sumarotene** solutions immediately before use whenever possible.
- Control temperature: Store stock solutions and experimental samples at recommended low temperatures, typically -20°C, and protect them from light.

Troubleshooting Guide

Issue	Possible Cause	Recommended Solution
Inconsistent results in bioassays	Photodegradation of Sumarotene leading to variable active compound concentration.	Implement strict light-protection protocols for all steps of the experiment. Prepare fresh dilutions for each experiment from a protected stock solution.
Appearance of unknown peaks in HPLC/UPLC analysis	Formation of photodegradation products.	Conduct a forced degradation study to identify potential degradation products. Use a stability-indicating analytical method capable of separating the parent drug from its degradants.
Loss of potency in formulated product over time	Inadequate protection from light by the formulation or packaging.	Evaluate the photoprotective qualities of the formulation excipients and packaging materials. Consider incorporating UV absorbers or antioxidants into the formulation.
Precipitation or phase separation in liquid formulations	Degradation products may have different solubility profiles.	Characterize the degradation products to understand their physicochemical properties. Reformulate with solubilizing agents that are compatible with both the parent drug and its degradants.

Experimental Protocols

Protocol 1: Forced Photodegradation Study of Sumarotene

This protocol is based on the ICH Q1B guidelines for photostability testing.

Objective: To intentionally degrade **Sumarotene** under controlled light exposure to identify potential degradation products and establish its photodegradation pathway.

Materials:

- **Sumarotene** (drug substance)
- Solvent (e.g., ethanol, acetonitrile/water)
- Chemically inert and transparent containers (e.g., quartz cuvettes or vials)
- Photostability chamber with a calibrated light source (cool white fluorescent and near-UV lamps)
- Control samples protected from light (e.g., wrapped in aluminum foil)
- HPLC or UPLC system with a photodiode array (PDA) or mass spectrometry (MS) detector

Method:

- Sample Preparation: Prepare a solution of **Sumarotene** in the chosen solvent at a known concentration (e.g., 0.1 mg/mL).
- Exposure:
 - Place the transparent containers with the **Sumarotene** solution in the photostability chamber.
 - Simultaneously, place the control samples (light-protected) in the same chamber to account for thermal degradation.
 - Expose the samples to a light source that provides an overall illumination of not less than 1.2 million lux hours and an integrated near-ultraviolet energy of not less than 200 watt hours/square meter.
- Sampling: Withdraw aliquots of the exposed and control samples at predetermined time points (e.g., 0, 2, 4, 8, 12, and 24 hours).

- Analysis:
 - Analyze the samples by a validated stability-indicating HPLC or UPLC-MS/MS method.
 - Monitor for the appearance of new peaks and a decrease in the peak corresponding to **Sumarotene**.
 - Characterize the structure of the major degradation products using MS/MS fragmentation analysis.

Protocol 2: Evaluating the Photostability of a Sumarotene Topical Formulation

Objective: To assess the effectiveness of a topical formulation in protecting **Sumarotene** from photodegradation.

Materials:

- **Sumarotene** topical formulation
- Inert transparent substrate (e.g., quartz plates or a suitable membrane)
- Photostability chamber
- Extraction solvent
- HPLC or UPLC system

Method:

- Sample Application: Apply a thin, uniform layer of the **Sumarotene** formulation onto the inert substrate.
- Exposure:
 - Place the prepared substrates in the photostability chamber.
 - Expose the samples to the same light conditions as described in Protocol 1.

- Include control plates that are protected from light.
- Extraction: At specified time intervals, remove the substrates from the chamber and extract the formulation using a suitable solvent.
- Analysis: Analyze the extracted samples using a validated HPLC or UPLC method to quantify the remaining **Sumarotene** and any degradation products.
- Comparison: Compare the degradation profile of **Sumarotene** in the formulation to that of the unformulated drug substance to determine the photoprotective effect of the formulation.

Data Presentation

Table 1: Forced Photodegradation of **Sumarotene** in Solution

Time (hours)	Sumarotene (% remaining) - Exposed	Sumarotene (% remaining) - Control	Total Degradation Products (% peak area) - Exposed
0	100.0	100.0	0.0
2	95.2	99.8	4.8
4	88.9	99.5	11.1
8	76.5	99.2	23.5
12	65.1	98.9	34.9
24	48.3	98.5	51.7

Table 2: Photostability of **Sumarotene** in different Topical Formulations

Formulation	Sumarotene Degradation after 8h exposure (%)	Key Excipients
Formulation A (Simple Gel)	25.8	Carbomer, Propylene Glycol
Formulation B (Cream with UV Absorber)	8.2	Cetyl Alcohol, Stearyl Alcohol, Titanium Dioxide
Formulation C (Nanoemulsion)	5.5	Medium Chain Triglycerides, Polysorbate 80, Lecithin

Visualizations

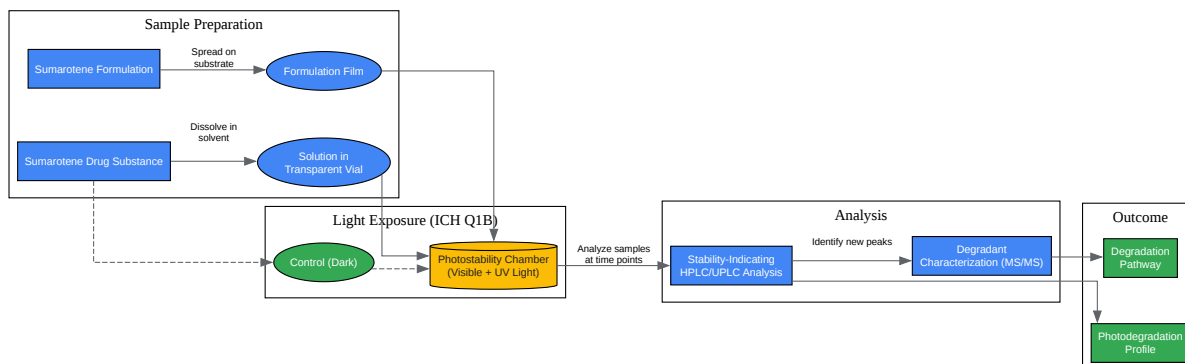

[Click to download full resolution via product page](#)

Caption: Workflow for assessing **Sumarotene** photostability.

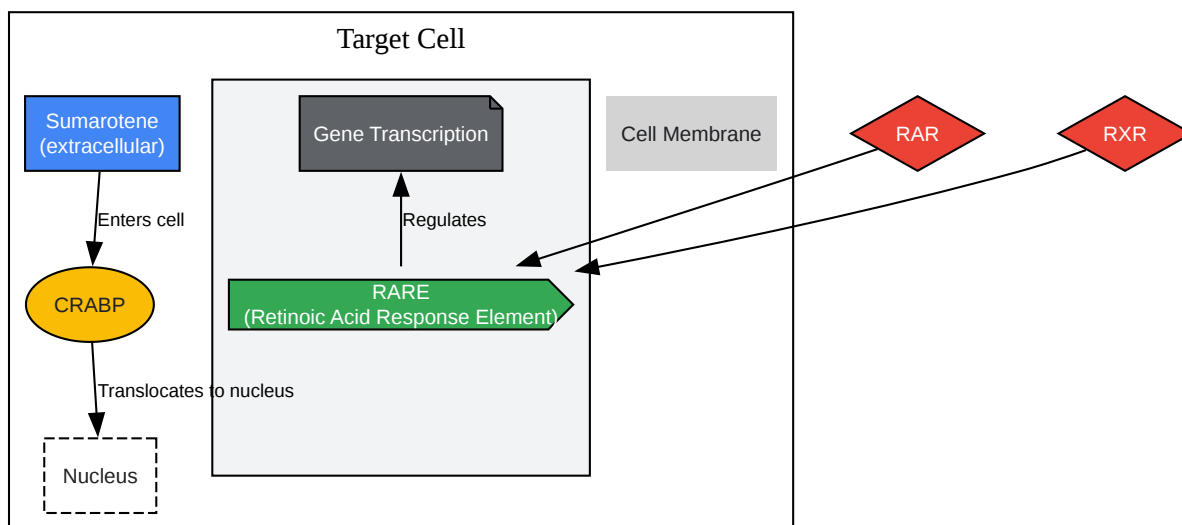

[Click to download full resolution via product page](#)

Caption: Generalized retinoid signaling pathway.

Need Custom Synthesis?

BenchChem offers custom synthesis for rare earth carbides and specific isotopic labeling.

Email: info@benchchem.com or [Request Quote Online](#).

References

- 1. medchemexpress.com [medchemexpress.com]
- 2. mdpi.com [mdpi.com]
- 3. A Clinician's Guide to Topical Retinoids - PMC [pmc.ncbi.nlm.nih.gov]
- 4. researchgate.net [researchgate.net]
- 5. Photostability Testing of a Third-Generation Retinoid—Tazarotene in the Presence of UV Absorbers - PMC [pmc.ncbi.nlm.nih.gov]
- To cite this document: BenchChem. [How to control for Sumarotene photostability in experiments]. BenchChem, [2025]. [Online PDF]. Available at:

[<https://www.benchchem.com/product/b1637876#how-to-control-for-sumarotene-photostability-in-experiments>]

Disclaimer & Data Validity:

The information provided in this document is for Research Use Only (RUO) and is strictly not intended for diagnostic or therapeutic procedures. While BenchChem strives to provide accurate protocols, we make no warranties, express or implied, regarding the fitness of this product for every specific experimental setup.

Technical Support: The protocols provided are for reference purposes. Unsure if this reagent suits your experiment? [[Contact our Ph.D. Support Team for a compatibility check](#)]

Need Industrial/Bulk Grade? [Request Custom Synthesis Quote](#)

BenchChem

Our mission is to be the trusted global source of essential and advanced chemicals, empowering scientists and researchers to drive progress in science and industry.

Contact

Address: 3281 E Guasti Rd
Ontario, CA 91761, United States
Phone: (601) 213-4426
Email: info@benchchem.com