

H3B-5942 solubility issues and recommended solvents

Author: BenchChem Technical Support Team. **Date:** December 2025

Compound of Interest

Compound Name: H3B-5942

Cat. No.: B15544998

[Get Quote](#)

H3B-5942 Technical Support Center

This technical support center provides researchers, scientists, and drug development professionals with a comprehensive guide to the solubility of **H3B-5942**, including troubleshooting advice and detailed protocols to ensure successful experimental outcomes.

Frequently Asked Questions (FAQs)

Q1: What is **H3B-5942** and its mechanism of action?

A1: **H3B-5942** is a selective, irreversible, and orally active covalent antagonist of the estrogen receptor (ER α).^{[1][2]} It inactivates both wild-type and mutant forms of ER α by targeting the cysteine 530 residue.^{[2][3][4]} This binding induces a unique antagonist conformation in ER α , leading to the blockage of ER α -dependent transcription in breast cancer cells and a reduction in the expression of ER α target genes like GREB1.

Q2: What are the recommended solvents for dissolving **H3B-5942**?

A2: The recommended solvent for creating stock solutions of **H3B-5942** is fresh, anhydrous Dimethyl Sulfoxide (DMSO). It is also soluble in Ethanol to a lesser extent and is considered insoluble in water.

Q3: Are there any specific storage conditions for **H3B-5942** solutions?

A3: Yes, proper storage is crucial to maintain the stability and activity of **H3B-5942**. Stock solutions in DMSO should be aliquoted to avoid repeated freeze-thaw cycles and stored at -80°C for long-term stability (up to 2 years) or -20°C for shorter periods (up to 1 year).

Solubility Data

The following table summarizes the solubility of **H3B-5942** in various solvents. Please note that solubility can be affected by factors such as temperature, pH, and the purity of the solvent.

Solvent	Concentration (mg/mL)	Molar Concentration (mM)	Notes
DMSO	83.33 - 99	168.47 - 200.14	Ultrasonic treatment may be needed. Use of fresh, anhydrous DMSO is highly recommended as hygroscopic DMSO can significantly decrease solubility.
Ethanol	13	Not Specified	
Water	Insoluble	Insoluble	

Troubleshooting Guide

Q1: My **H3B-5942** powder is not dissolving in DMSO, what should I do?

A1: If you are experiencing difficulty dissolving **H3B-5942** in DMSO, please follow these steps:

- **Verify DMSO Quality:** Ensure you are using fresh, anhydrous (moisture-free) DMSO. Old or improperly stored DMSO can absorb moisture, which significantly reduces the solubility of **H3B-5942**.
- **Gentle Warming:** Warm the solution gently to 37°C. Do not overheat, as it may degrade the compound.

- **Sonication:** Use an ultrasonic bath to aid dissolution. This can help break up any clumps of powder and increase the surface area for the solvent to act upon.
- **Increase Solvent Volume:** If the concentration is high, try adding more DMSO to dilute the solution.

Q2: The **H3B-5942** solution precipitated after being stored. Can I still use it?

A2: Precipitation upon storage, especially after refrigeration, can occur. To redissolve the compound, gently warm the vial to 37°C and vortex or sonicate until the solution is clear. Before use, visually inspect the solution to ensure no crystals are present. If precipitation persists, it may indicate that the compound has exceeded its solubility limit at that temperature.

Q3: I observed precipitation when diluting my DMSO stock solution with aqueous media. How can I prevent this?

A3: This is a common issue when diluting a compound from a high-concentration organic stock into an aqueous buffer. To minimize precipitation:

- **Use a Surfactant:** For in vivo preparations, formulations often include surfactants like Tween-80 or PEG300 to maintain solubility.
- **Stepwise Dilution:** Perform serial dilutions, gradually decreasing the concentration of DMSO.
- **Vortexing During Dilution:** Add the stock solution to the aqueous buffer dropwise while vigorously vortexing to ensure rapid mixing.
- **Work at Room Temperature:** Ensure both the stock solution and the aqueous buffer are at room temperature.

Experimental Protocols

Protocol for Preparing a 10 mM Stock Solution of **H3B-5942** in DMSO

- **Materials:** **H3B-5942** powder (Molecular Weight: 494.63 g/mol), anhydrous DMSO, sterile microcentrifuge tubes.

- Calculation: To prepare a 10 mM stock solution, you will need 4.946 mg of **H3B-5942** per 1 mL of DMSO.
- Procedure: a. Weigh out the required amount of **H3B-5942** powder in a sterile microcentrifuge tube. b. Add the calculated volume of fresh, anhydrous DMSO. c. Vortex the tube for 1-2 minutes to mix. d. If the compound is not fully dissolved, place the tube in an ultrasonic water bath for 5-10 minutes. e. Visually inspect the solution to ensure it is clear and free of particulates. f. Aliquot the stock solution into smaller volumes to avoid multiple freeze-thaw cycles. g. Store the aliquots at -80°C.

Visualizations

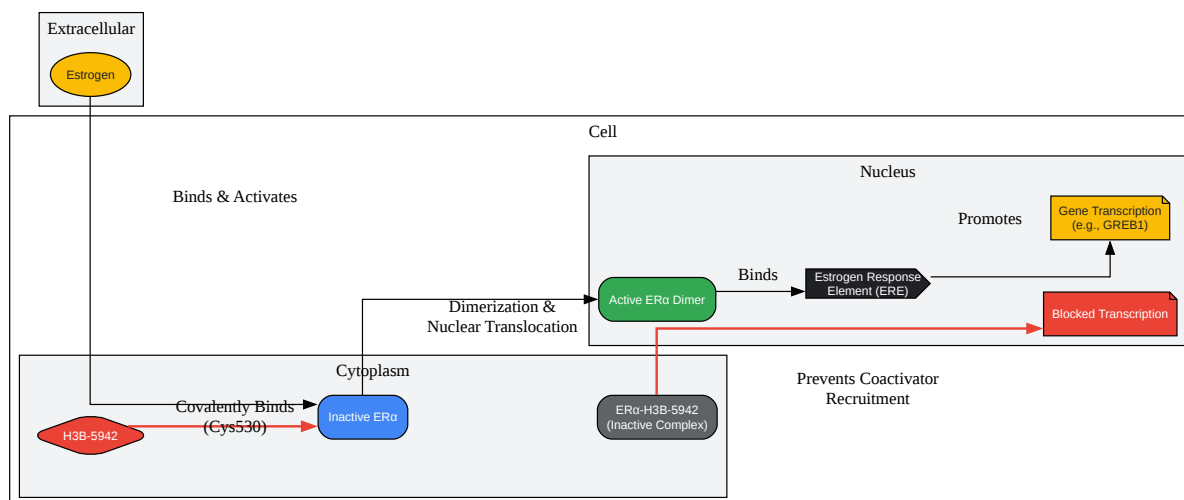

[Click to download full resolution via product page](#)

Caption: Mechanism of **H3B-5942** as an ER α antagonist.

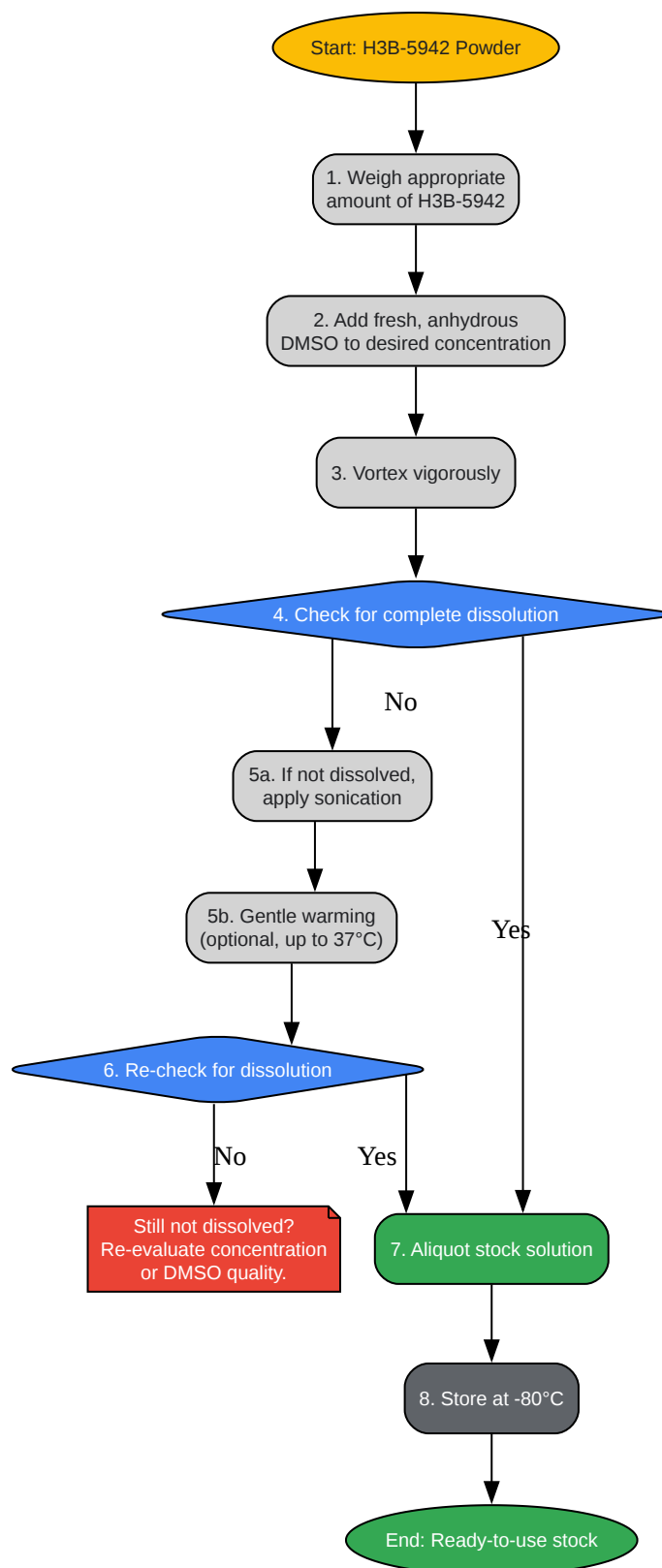

[Click to download full resolution via product page](#)

Caption: Experimental workflow for dissolving **H3B-5942**.

Need Custom Synthesis?

BenchChem offers custom synthesis for rare earth carbides and specific isotopic labeling.

Email: info@benchchem.com or [Request Quote Online](#).

References

- 1. medchemexpress.com [medchemexpress.com]
- 2. selleckchem.com [selleckchem.com]
- 3. aacrjournals.org [aacrjournals.org]
- 4. cancer-research-network.com [cancer-research-network.com]
- To cite this document: BenchChem. [H3B-5942 solubility issues and recommended solvents]. BenchChem, [2025]. [Online PDF]. Available at: [https://www.benchchem.com/product/b15544998#h3b-5942-solubility-issues-and-recommended-solvents]

Disclaimer & Data Validity:

The information provided in this document is for Research Use Only (RUO) and is strictly not intended for diagnostic or therapeutic procedures. While BenchChem strives to provide accurate protocols, we make no warranties, express or implied, regarding the fitness of this product for every specific experimental setup.

Technical Support: The protocols provided are for reference purposes. Unsure if this reagent suits your experiment? [[Contact our Ph.D. Support Team for a compatibility check](#)]

Need Industrial/Bulk Grade? [Request Custom Synthesis Quote](#)

BenchChem

Our mission is to be the trusted global source of essential and advanced chemicals, empowering scientists and researchers to drive progress in science and industry.

Contact

Address: 3281 E Guasti Rd
Ontario, CA 91761, United States
Phone: (601) 213-4426
Email: info@benchchem.com