

Glisoprenin D: A Fungal Metabolite with Potential as a Novel Agrochemical

Author: BenchChem Technical Support Team. **Date:** December 2025

Compound of Interest

Compound Name: *Glisoprenin D*

Cat. No.: *B2372758*

[Get Quote](#)

An In-depth Technical Guide on the Natural Source, Production, and Biological Activity of **Glisoprenin D**

For Researchers, Scientists, and Drug Development Professionals

Abstract

Glisoprenin D, a member of the glisoprenin family of fungal metabolites, has garnered interest for its specific biological activity against the rice blast fungus, *Magnaporthe grisea*. This technical guide provides a comprehensive overview of the natural source of **Glisoprenin D**, detailed methodologies for its production through fermentation, and an exploration of its proposed biosynthetic origins and mechanism of action. The information presented herein is intended to serve as a valuable resource for researchers in natural product chemistry, mycology, and agrochemical development.

Natural Source and Biological Activity

Glisoprenin D is a naturally occurring polyisoprenepolyol produced by the filamentous fungus *Gliocladium roseum*.^[1] It was co-isolated with other **glisoprenin** derivatives, including glisoprenins C and E, from submerged cultures of *G. roseum* strain HA190-95.^[1] The primary and most notable biological activity of **Glisoprenin D** and its analogues is the potent and specific inhibition of appressorium formation in the devastating rice blast fungus, *Magnaporthe grisea*.^[1] Appressoria are specialized infection structures essential for the fungus to penetrate the host plant tissue. By inhibiting their formation, **Glisoprenin D** effectively prevents fungal

invasion. While exhibiting this targeted antifungal action, glisoprenins have been reported to show only moderate cytotoxic, and no general antifungal, antibacterial, or phytotoxic activities, highlighting their potential for development as a selective agrochemical.[1]

Production of Glisoprenin D

The production of **Glisoprenin D** is achieved through submerged fermentation of *Gliocladium roseum*. While specific yields for **Glisoprenin D** are not extensively reported in publicly available literature, a general methodology can be derived from protocols for the cultivation of *G. roseum* and the isolation of similar fungal metabolites.

Fermentation Protocol

The following protocol is adapted from a patented method for the liquid fermentation of *Gliocladium roseum* for the production of chlamydospores, which can be modified for the production of secondary metabolites like **Glisoprenin D**.

Table 1: Fermentation Parameters for *Gliocladium roseum*

Parameter	Value/Range
Culture Medium	
Sucrose	40-50 g/L
Bean Cake Powder	20-25 g/L
Potassium Dihydrogen Phosphate	0.5-2 g/L
Magnesium Sulfate	0.2-1 g/L
Inoculation	
Inoculum Type	Spore suspension or mycelial culture
Inoculum Size	0.2% - 2% (v/v)
Fermentation Conditions	
pH	4.0 - 6.0
Temperature	26°C - 30°C
Agitation	180 - 250 rpm
Aeration	1:0.2 - 1:0.8 (vessel volume:air volume per minute)
Fermentation Time	3 - 5 days

Experimental Workflow for Production and Isolation

The following diagram illustrates a typical workflow for the production and isolation of **Glisoprenin D** from *Gliocladium roseum* cultures.

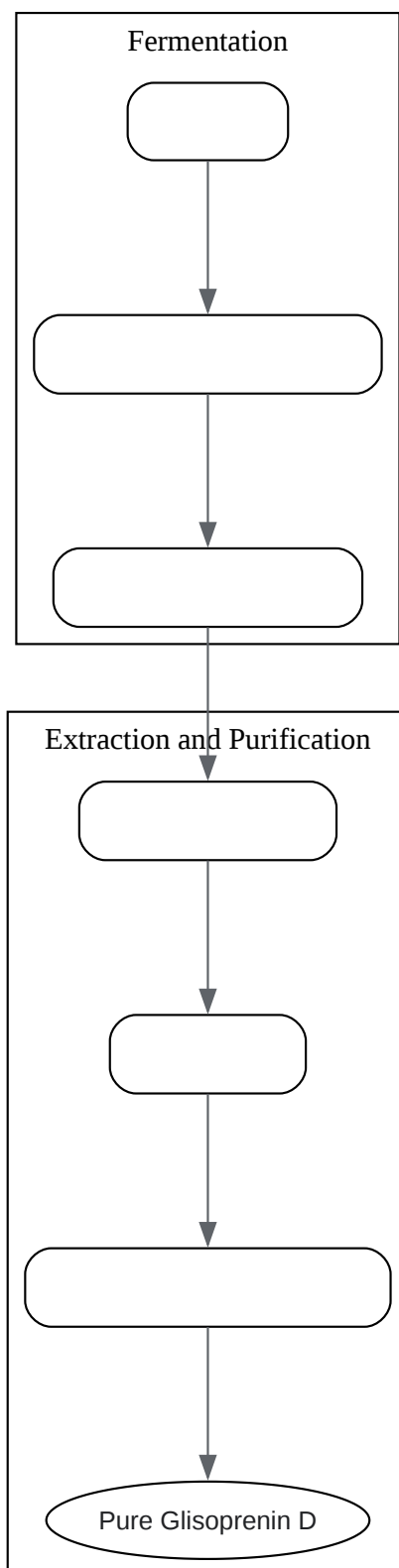

[Click to download full resolution via product page](#)

A generalized workflow for the production and isolation of **Glisoprenin D**.

Biosynthesis of Glisoprenin D (Proposed Pathway)

The precise biosynthetic pathway of **Glisoprenin D** has not been fully elucidated. However, based on its polyisoprenoid structure, it is hypothesized to be derived from the terpenoid biosynthetic pathway. Fungi typically utilize the mevalonate (MVA) pathway for the synthesis of the universal isoprene precursors, isopentenyl pyrophosphate (IPP) and dimethylallyl pyrophosphate (DMAPP).

The biosynthesis of the **Glisoprenin D** backbone is likely initiated by a prenyltransferase, which catalyzes the sequential condensation of IPP units onto a starter molecule, possibly DMAPP or another prenyl pyrophosphate. The resulting polyisoprenoid chain would then undergo a series of modifications, including hydroxylation and cyclization, catalyzed by specific enzymes such as cytochrome P450 monooxygenases and terpene cyclases, to yield the final structure of **Glisoprenin D**.

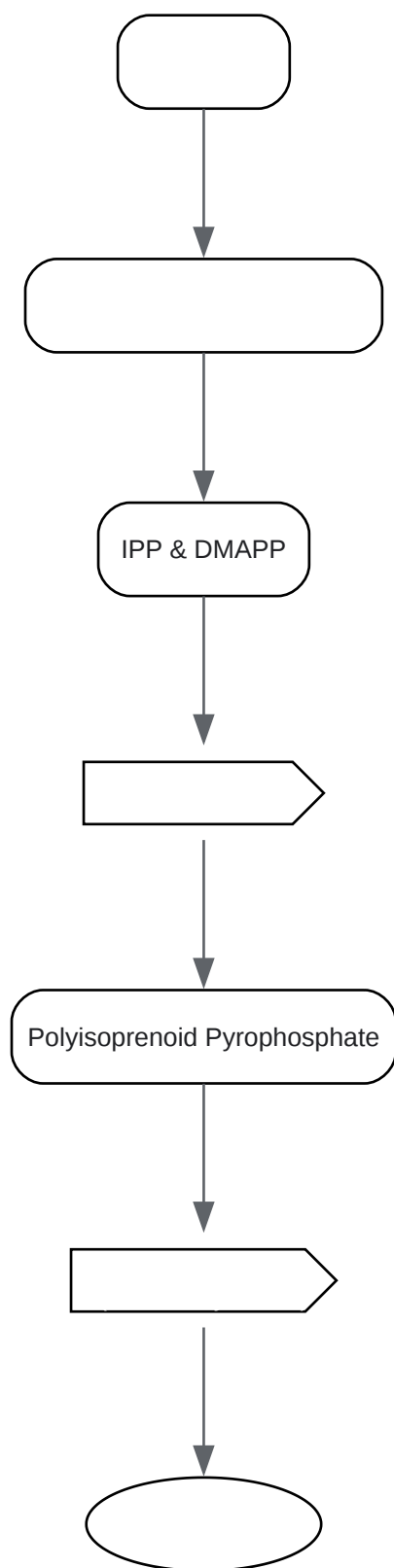

[Click to download full resolution via product page](#)

A proposed biosynthetic pathway for **Glisoprenin D**.

Total Synthesis

To date, a total synthesis of **Glisoprenin D** has not been reported in the scientific literature. The complex stereochemistry and the long polyisoprenoid chain present significant challenges for chemical synthesis. However, the development of novel synthetic methodologies for the construction of polyketide and polyisoprenoid natural products may pave the way for the future synthesis of **Glisoprenin D** and its analogues. Such a synthesis would be invaluable for confirming the absolute stereochemistry of the natural product and for generating derivatives to explore structure-activity relationships.

Mechanism of Action: Inhibition of Appressorium Formation

Glisoprenin D inhibits the formation of appressoria in *M. grisea*, a process triggered by physical cues such as the hydrophobicity of the host plant surface. This signaling pathway is known to be distinct from the cAMP-dependent pathway, which can also induce appressorium formation. While the precise molecular target of **Glisoprenin D** remains to be identified, it is proposed to interfere with a key component of the hydrophobic surface sensing signal transduction cascade. This could involve the inhibition of a specific receptor, kinase, or downstream effector protein essential for the morphological changes that lead to appressorium development.

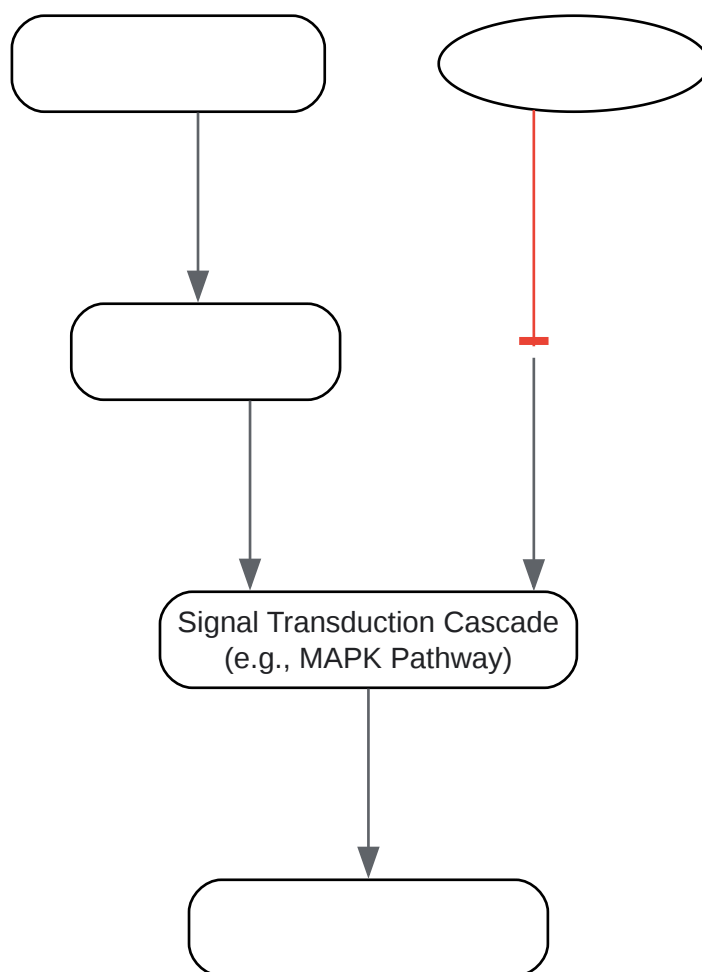

[Click to download full resolution via product page](#)

Proposed mechanism of action for **Glisoprenin D**.

Future Perspectives

Glisoprenin D represents a promising lead compound for the development of a new class of fungicides with a specific mode of action. Future research should focus on several key areas:

- **Elucidation of the Biosynthetic Pathway:** Identification and characterization of the gene cluster responsible for glisoprenin biosynthesis in *G. roseum* would enable the use of synthetic biology approaches to increase production titers and generate novel derivatives.
- **Total Synthesis and Analogue Development:** A successful total synthesis would provide access to larger quantities of **Glisoprenin D** and facilitate the synthesis of analogues with improved potency, stability, and selectivity.

- Identification of the Molecular Target: Pinpointing the specific protein(s) that **Glisoprenin D** interacts with in *M. grisea* is crucial for understanding its mechanism of action and for the rational design of more effective inhibitors.

The continued investigation of **Glisoprenin D** and other natural products from underexplored fungal sources holds significant promise for addressing the ongoing challenge of resistance in agricultural pathogens.

Need Custom Synthesis?

BenchChem offers custom synthesis for rare earth carbides and specific isotopic labeling.

Email: info@benchchem.com or [Request Quote Online](#).

References

- 1. Glisoprenins C, D and E, new inhibitors of appressorium formation in *Magnaporthe grisea*, from cultures of *Gliocladium roseum*. 1. Production and biological activities - PubMed [pubmed.ncbi.nlm.nih.gov]
- To cite this document: BenchChem. [Glisoprenin D: A Fungal Metabolite with Potential as a Novel Agrochemical]. BenchChem, [2025]. [Online PDF]. Available at: [<https://www.benchchem.com/product/b2372758#natural-source-and-production-of-glisoprenin-d>]

Disclaimer & Data Validity:

The information provided in this document is for Research Use Only (RUO) and is strictly not intended for diagnostic or therapeutic procedures. While BenchChem strives to provide accurate protocols, we make no warranties, express or implied, regarding the fitness of this product for every specific experimental setup.

Technical Support: The protocols provided are for reference purposes. Unsure if this reagent suits your experiment? [[Contact our Ph.D. Support Team for a compatibility check](#)]

Need Industrial/Bulk Grade? [Request Custom Synthesis Quote](#)

BenchChem

Our mission is to be the trusted global source of essential and advanced chemicals, empowering scientists and researchers to drive progress in science and industry.

Contact

Address: 3281 E Guasti Rd

Ontario, CA 91761, United States

Phone: (601) 213-4426

Email: info@benchchem.com