

Glasdegib-d4 Technical Support Center: Addressing Isotopic Exchange

Author: BenchChem Technical Support Team. **Date:** December 2025

Compound of Interest

Compound Name: Glasdegib-d4

Cat. No.: B15545245

[Get Quote](#)

This technical support center provides researchers, scientists, and drug development professionals with comprehensive guidance on troubleshooting and mitigating isotopic exchange issues when using **Glasdegib-d4** as an internal standard in quantitative mass spectrometry assays.

Frequently Asked Questions (FAQs)

Q1: What is **Glasdegib-d4** and why is it used?

A1: **Glasdegib-d4** is a stable isotope-labeled version of Glasdegib, a drug used in the treatment of acute myeloid leukemia (AML).[1][2] In **Glasdegib-d4**, four hydrogen atoms have been replaced with deuterium, a heavier, stable isotope of hydrogen. This mass difference allows it to be used as an ideal internal standard in quantitative liquid chromatography-mass spectrometry (LC-MS) assays.[3] By adding a known amount of **Glasdegib-d4** to a sample at the beginning of the preparation process, it can accurately correct for variations in sample extraction, handling, and instrument response, ensuring precise quantification of the unlabeled Glasdegib.[3][4]

Q2: What is isotopic exchange and why is it a concern for **Glasdegib-d4**?

A2: Isotopic exchange is a chemical reaction where a deuterium atom on a labeled compound, like **Glasdegib-d4**, is swapped for a hydrogen atom from the surrounding environment (e.g., solvents, reagents). This process, also known as back-exchange, compromises the integrity of the internal standard by converting it to lighter versions (Glasdegib-d3, -d2, etc.), leading to

inaccurate and unreliable quantification of the target analyte. The stability of the deuterium label is critical, and exchange can be influenced by factors such as pH, temperature, and the specific location of the deuterium atoms on the molecule.

Q3: Where are the deuterium labels on **Glasdegib-d4** located and are they stable?

A3: For optimal stability, deuterium labels should be placed on non-exchangeable positions within a molecule, such as aliphatic or aromatic carbon atoms. Placing them on heteroatoms (e.g., -OH, -NH, -SH groups) should be avoided as these positions are prone to rapid exchange with protic solvents. While the exact position of deuteration on commercially available **Glasdegib-d4** should be confirmed from the certificate of analysis, manufacturers typically prioritize labeling at stable positions to ensure its suitability as an internal standard.

Q4: What are the primary experimental factors that can induce isotopic exchange?

A4: Several factors can promote the unwanted exchange of deuterium for hydrogen:

- **pH:** Both acidic and basic conditions can catalyze the exchange reaction. The minimum rate of exchange for many compounds occurs at a slightly acidic pH.
- **Temperature:** Higher temperatures increase the rate of chemical reactions, including isotopic exchange.
- **Solvents:** The presence of protic solvents (e.g., water, methanol) is necessary for the exchange to occur. The type of solvent and any additives can influence the exchange rate.
- **Enzymatic Activity:** In biological matrices, enzymes could potentially facilitate isotopic exchange, although this is less common for labels on stable carbon positions.

Troubleshooting Guides

This section provides a structured approach to identifying and resolving common issues related to the stability and performance of **Glasdegib-d4** in LC-MS assays.

Issue 1: Inconsistent or Drifting Internal Standard (IS) Response

- Symptom: The peak area of **Glasdegib-d4** is highly variable across a batch of samples, including calibrators and quality controls.
- Potential Cause: Isotopic exchange occurring during sample preparation or storage.
- Troubleshooting Steps:
 - Assess Stability in Matrix: Perform an experiment to confirm the stability of **Glasdegib-d4** under your specific experimental conditions.
 - Review Sample Preparation Conditions:
 - pH: Measure the pH of your solutions. If highly acidic or basic, consider adjusting to a more neutral pH range if the assay allows.
 - Temperature: Avoid exposing samples to high temperatures. If heating is required, minimize the duration. Perform sample preparation steps on ice where possible.
 - Check for Contamination: Ensure that the unlabeled Glasdegib stock solution has not contaminated the **Glasdegib-d4** solution. Analyze the IS spiking solution alone to confirm the absence of a significant signal at the mass transition of the unlabeled analyte.

Issue 2: Appearance of Unlabeled Glasdegib in Blank Samples

- Symptom: A peak corresponding to unlabeled Glasdegib is detected when analyzing a blank matrix sample spiked only with **Glasdegib-d4**.
- Potential Cause: In-source fragmentation of the deuterated standard or isotopic exchange.
- Troubleshooting Steps:
 - Optimize Mass Spectrometer Source Conditions: High source temperatures or energetic conditions can sometimes cause the loss of deuterium atoms. Methodically reduce source temperature and other relevant parameters to see if the signal for the unlabeled analyte decreases.

- Perform a Stability Experiment: Incubate a solution of **Glasdegib-d4** in the final sample solvent at various time points (e.g., 0, 2, 8, 24 hours) and analyze the samples. A time-dependent increase in the unlabeled Glasdegib signal is a clear indicator of isotopic exchange.

Experimental Protocols

Protocol 1: Assessing the Stability of Glasdegib-d4 in Solution

This protocol is designed to determine if isotopic exchange is occurring under your specific analytical conditions.

Objective: To quantify the conversion of **Glasdegib-d4** to unlabeled Glasdegib over time in a given solvent or matrix.

Materials:

- **Glasdegib-d4** stock solution
- Unlabeled Glasdegib stock solution
- Blank matrix (e.g., human plasma) or analytical solvent
- LC-MS system

Methodology:

- Prepare Stability Samples:
 - Spike a known concentration of **Glasdegib-d4** into the blank matrix or solvent. The concentration should be consistent with what is used in your analytical method.
 - Aliquot this mixture into several vials.
- Incubation:

- Store the vials under the same conditions (temperature, light exposure) as your typical sample queue.
- Analyze one vial immediately (T=0).
- Analyze subsequent vials at predetermined time points (e.g., 4, 8, 12, and 24 hours).
- LC-MS Analysis:
 - Analyze each sample, monitoring the multiple reaction monitoring (MRM) transitions for both **Glasdegib-d4** and unlabeled Glasdegib.
- Data Analysis:
 - Calculate the peak area ratio of unlabeled Glasdegib to **Glasdegib-d4** at each time point.
 - An increase in this ratio over time indicates that isotopic exchange is occurring.

Data Presentation:

Time Point (Hours)	Glasdegib-d4 Peak Area	Unlabeled Glasdegib Peak Area	Area Ratio (Unlabeled/d4)	% Exchange
0	1,540,000	7,800	0.0051	0.51%
4	1,535,000	15,500	0.0101	1.01%
8	1,542,000	23,100	0.0150	1.50%
12	1,530,000	31,200	0.0204	2.04%
24	1,538,000	55,400	0.0360	3.60%

Assumes the T=0 value represents the initial isotopic purity of the standard.

Visualizations

Glasdegib's Mechanism of Action

Glasdegib functions by inhibiting the Hedgehog signaling pathway, a crucial pathway in cell regulation. It specifically targets the Smoothed (SMO) receptor, which, when activated, leads to a signaling cascade that promotes the activation of GLI transcription factors and subsequent gene expression involved in cell proliferation.

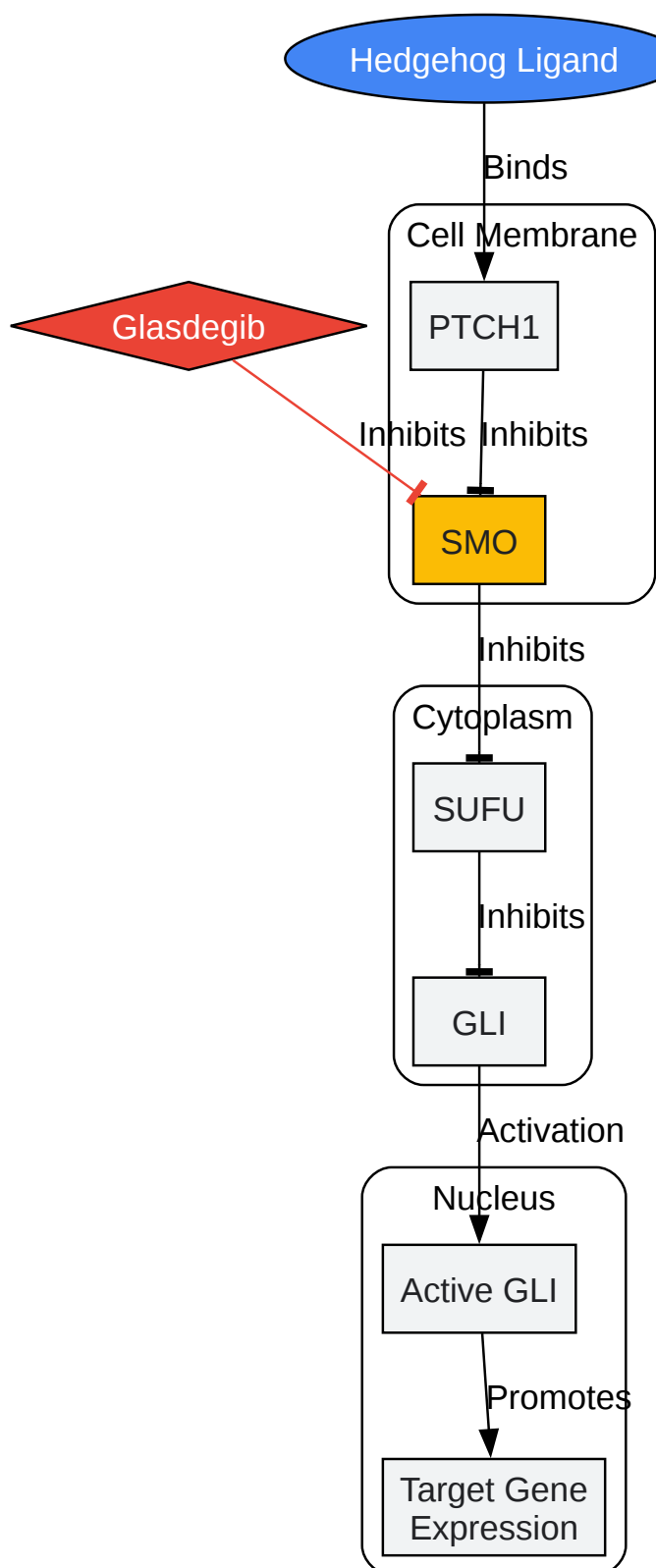

[Click to download full resolution via product page](#)

Caption: Simplified Hedgehog signaling pathway showing inhibition by Glasdegib.

Experimental Workflow for Stability Assessment

A logical workflow is critical for systematically diagnosing issues with isotopic exchange.

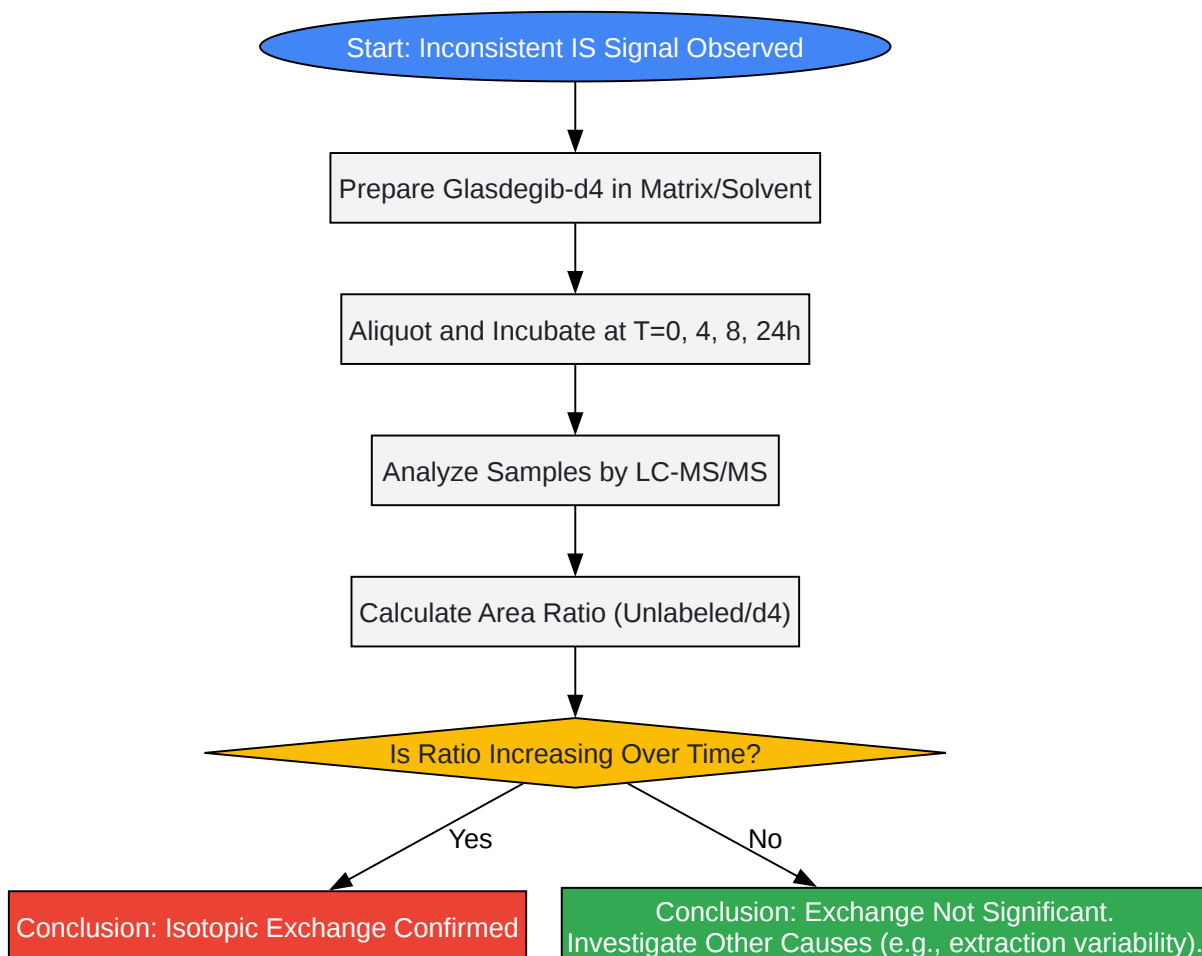

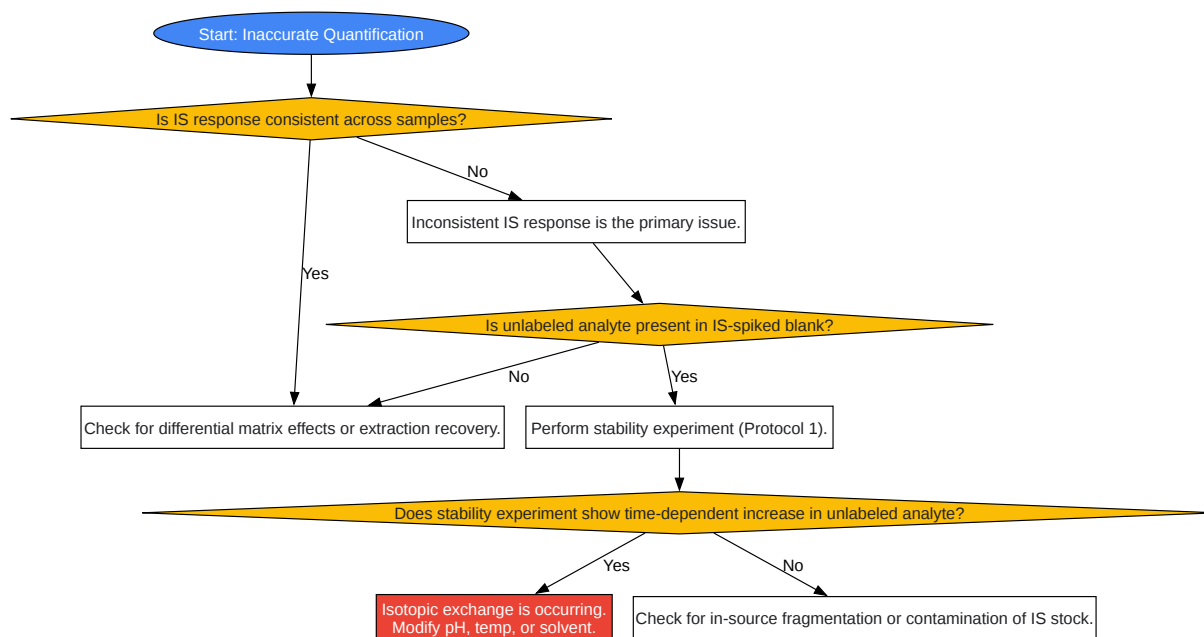

[Click to download full resolution via product page](#)

Need Custom Synthesis?

BenchChem offers custom synthesis for rare earth carbides and specific isotopic labeling.

Email: info@benchchem.com or [Request Quote Online](#).

References

- 1. go.drugbank.com [go.drugbank.com]
- 2. cancernetwork.com [cancernetwork.com]
- 3. benchchem.com [benchchem.com]
- 4. nebiolab.com [nebiolab.com]
- To cite this document: BenchChem. [Glasdegib-d4 Technical Support Center: Addressing Isotopic Exchange]. BenchChem, [2025]. [Online PDF]. Available at: [<https://www.benchchem.com/product/b15545245#addressing-isotopic-exchange-issues-with-glasdegib-d4>]

Disclaimer & Data Validity:

The information provided in this document is for Research Use Only (RUO) and is strictly not intended for diagnostic or therapeutic procedures. While BenchChem strives to provide accurate protocols, we make no warranties, express or implied, regarding the fitness of this product for every specific experimental setup.

Technical Support: The protocols provided are for reference purposes. Unsure if this reagent suits your experiment? [[Contact our Ph.D. Support Team for a compatibility check](#)]

Need Industrial/Bulk Grade? [Request Custom Synthesis Quote](#)

BenchChem

Our mission is to be the trusted global source of essential and advanced chemicals, empowering scientists and researchers to drive progress in science and industry.

Contact

Address: 3281 E Guasti Rd
Ontario, CA 91761, United States
Phone: (601) 213-4426
Email: info@benchchem.com