

Foretinib in Mouse Xenograft Models: Application Notes and Protocols

Author: BenchChem Technical Support Team. **Date:** December 2025

Compound of Interest

Compound Name: *Foretinib*

Cat. No.: *B7856092*

[Get Quote](#)

For Researchers, Scientists, and Drug Development Professionals

These application notes provide a comprehensive overview of the dosage, administration, and efficacy of **foretinib** in various mouse xenograft models. The included protocols and data are intended to guide researchers in designing and executing preclinical studies to evaluate the therapeutic potential of this multi-kinase inhibitor.

Foretinib is an orally available small-molecule inhibitor that primarily targets the MET, VEGFR2, and RON receptor tyrosine kinases, playing a crucial role in tumor cell proliferation, invasion, and angiogenesis.[1][2][3] Preclinical studies in various cancer models have demonstrated its potent anti-tumor activity.[1]

Data Summary: Foretinib Efficacy in Mouse Xenograft Models

The following tables summarize the quantitative data from various studies on the use of **foretinib** in mouse xenograft models.

Table 1: **Foretinib** Dosage and Efficacy in Ovarian Cancer Xenograft Models

Cell Line	Mouse Strain	Foretinib Dose	Dosing Schedule	Administration Route	Tumor Growth Inhibition	Metastasis Inhibition	Reference
SKOV3ip 1	Athymic Nude	30 mg/kg	6 days/week for 21 days	Oral	86%	67%	[4]
HeyA8	Athymic Nude	30 mg/kg	Not Specified	Oral	71%	Not Reported	[4]

 Table 2: **Foretinib** Dosage and Efficacy in Gastric Cancer Xenograft Models

Cell Line	Mouse Strain	Foretinib Dose	Dosing Schedule	Administration Route	Tumor Growth Inhibition	Reference
MKN-45	Nude	6 mg/kg	Once daily for 21 days	Oral	Significant	[2]
MKN-45	Nude	10 mg/kg	Once daily for 21 days	Oral	Significant	[2]
MKN-45	Nude	30 mg/kg	Every other day for 42 days	Oral	Significant	[2]
MKN-45	NOD/SCID	Not Specified	Not Specified	Oral	59.4% (as monotherapy)	[5]
SNU-1	NOD/SCID	Not Specified	Not Specified	Oral	Antitumor activity observed	[5]

 Table 3: **Foretinib** Dosage and Efficacy in Other Cancer Xenograft Models

Cancer Type	Cell Line	Mouse Strain	Foretinib Dose	Dosing Schedule	Administration Route	Tumor Growth Inhibition Rate	Reference
Pancreatic Cancer	Panc-1	Not Specified	30 mg/kg	Once a day for 15 days	Oral gavage	Significant	[6]
Triple-Negative Breast Cancer	MDA-MB-231	Nude	15 mg/kg/day	For 18 days	Oral	42.79 ± 8.52%	[7]
Triple-Negative Breast Cancer	MDA-MB-231	Nude	50 mg/kg/day	For 18 days	Oral	79.16 ± 4.58%	[7]
Endometrial Cancer	HEC-108, TEN	Not Specified	30 mg/kg	Daily	Oral	Significant	[8]
Melanoma	B16F10	Not Specified	30 mg/kg	Not Specified	Not Specified	64%	[9]
Melanoma	B16F10	Not Specified	100 mg/kg	Not Specified	Not Specified	87%	[9]

Experimental Protocols

Protocol 1: General Procedure for Subcutaneous Xenograft Model

This protocol outlines a general procedure for establishing and treating subcutaneous tumor xenografts in mice. Specific details such as cell numbers and treatment start time may need to be optimized for different cell lines.

Materials:

- Cancer cell line of interest
- Appropriate cell culture medium
- Phosphate-buffered saline (PBS)
- Matrigel (optional)
- Immunocompromised mice (e.g., athymic nude, NOD/SCID)
- **Foretinib**
- Vehicle solution (e.g., 1% hydroxypropyl methylcellulose, 0.2% sodium lauryl sulfate in water)[2]
- Oral gavage needles
- Calipers

Procedure:

- Cell Preparation: Culture cancer cells to 70-80% confluency. Harvest cells using standard trypsinization methods and wash with PBS. Resuspend the cells in PBS or a mixture of PBS and Matrigel at the desired concentration (typically 1×10^6 to 10×10^6 cells per 100-200 μL).
- Tumor Implantation: Subcutaneously inject the cell suspension into the flank of the mice.
- Tumor Growth Monitoring: Monitor the mice regularly for tumor formation. Once tumors are palpable, measure their dimensions using calipers 2-3 times per week. Tumor volume can be calculated using the formula: $(\text{Length} \times \text{Width}^2) / 2$.
- Treatment Initiation: When the average tumor volume reaches a predetermined size (e.g., $\sim 180 \text{ mm}^3$), randomize the mice into treatment and control groups.[2]
- **Foretinib** Administration:

- Prepare a fresh formulation of **foretinib** in the vehicle solution at the desired concentration.
- Administer **foretinib** or vehicle to the respective groups via oral gavage according to the planned dosing schedule (e.g., daily, every other day).
- Monitoring: Continue to monitor tumor volume and the general health of the mice (including body weight) throughout the study.
- Endpoint: At the end of the study, euthanize the mice and excise the tumors for further analysis (e.g., weight measurement, immunohistochemistry, Western blotting).

Protocol 2: Peritoneal Dissemination Xenograft Model for Ovarian and Gastric Cancer

This protocol is adapted for studying metastatic cancer, particularly relevant for ovarian and gastric cancer models.

Materials:

- Same as Protocol 1.

Procedure:

- Cell Preparation: Prepare the cancer cell suspension as described in Protocol 1.
- Intraperitoneal Injection: Inject the cell suspension intraperitoneally into the mice.[4]
- Treatment Initiation: Begin treatment with **foretinib** or vehicle at a specified time point post-injection (e.g., 11 days for SKOV3ip1 cells).[4]
- **Foretinib** Administration: Administer **foretinib** or vehicle orally as per the dosing schedule.
- Monitoring: Monitor the mice for signs of tumor burden, such as abdominal distension and weight loss.
- Endpoint: At the study endpoint, euthanize the mice and perform a necropsy to count the number of metastatic tumor nodules and determine the total tumor weight.[4]

Visualizations

Signaling Pathway of Foretinib Inhibition

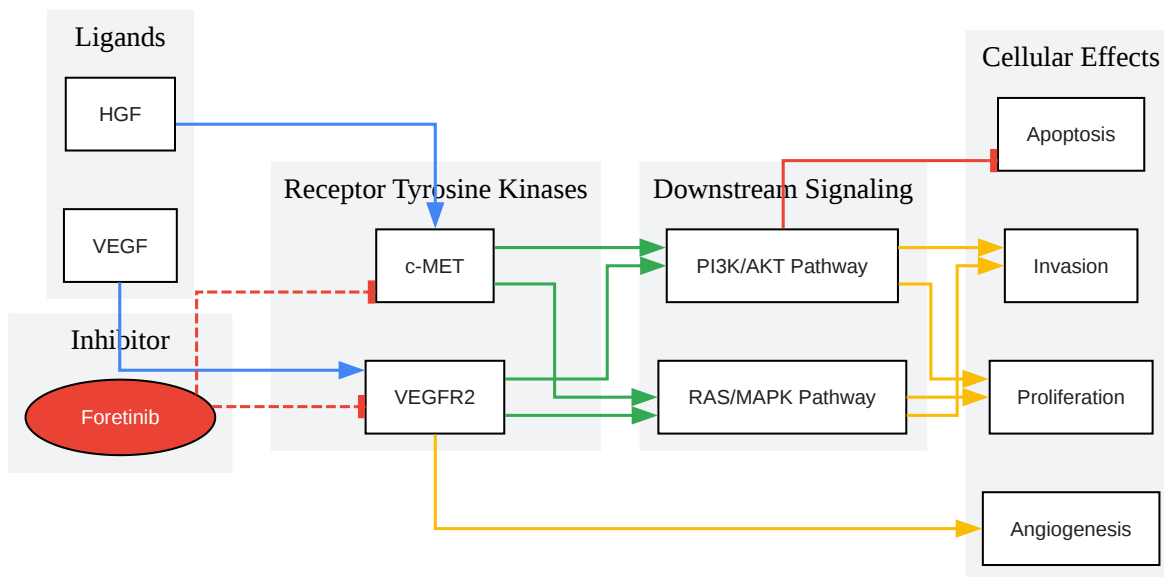

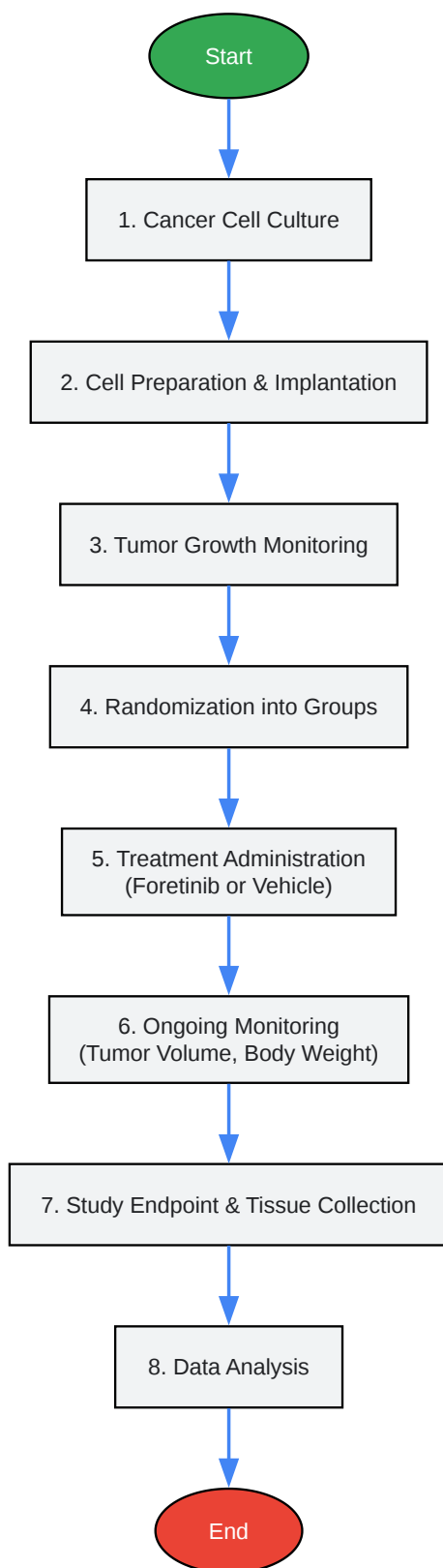

[Click to download full resolution via product page](#)

Need Custom Synthesis?

BenchChem offers custom synthesis for rare earth carbides and specific isotopic labeling.

Email: info@benchchem.com or [Request Quote Online](#).

References

- 1. go.drugbank.com [go.drugbank.com]
- 2. Phase II Study Evaluating 2 Dosing Schedules of Oral Foretinib (GSK1363089), cMET/VEGFR2 Inhibitor, in Patients with Metastatic Gastric Cancer - PMC [pmc.ncbi.nlm.nih.gov]
- 3. oncotarget.com [oncotarget.com]
- 4. Foretinib (GSK1363089), an orally available multi-kinase inhibitor of c-Met and VEGFR-2, blocks proliferation, induces anoikis, and impairs ovarian cancer metastasis - PMC [pmc.ncbi.nlm.nih.gov]
- 5. Targeted dual inhibition of c-Met/VEGFR2 signalling by foretinib improves antitumour effects of nanoparticle paclitaxel in gastric cancer models - PMC [pmc.ncbi.nlm.nih.gov]
- 6. Foretinib inhibits angiogenesis, lymphangiogenesis and tumor growth of pancreatic cancer in vivo by decreasing VEGFR-2/3 and TIE-2 signaling - PMC [pmc.ncbi.nlm.nih.gov]
- 7. Foretinib Is Effective against Triple-Negative Breast Cancer Cells MDA-MB-231 In Vitro and In Vivo by Down-Regulating p-MET/HGF Signaling - PMC [pmc.ncbi.nlm.nih.gov]
- 8. researchgate.net [researchgate.net]
- 9. medchemexpress.com [medchemexpress.com]
- To cite this document: BenchChem. [Foretinib in Mouse Xenograft Models: Application Notes and Protocols]. BenchChem, [2025]. [Online PDF]. Available at: [<https://www.benchchem.com/product/b7856092#foretinib-dosage-and-administration-in-mouse-xenograft-models>]

Disclaimer & Data Validity:

The information provided in this document is for Research Use Only (RUO) and is strictly not intended for diagnostic or therapeutic procedures. While BenchChem strives to provide

accurate protocols, we make no warranties, express or implied, regarding the fitness of this product for every specific experimental setup.

Technical Support: The protocols provided are for reference purposes. Unsure if this reagent suits your experiment? [[Contact our Ph.D. Support Team for a compatibility check](#)]

Need Industrial/Bulk Grade? [Request Custom Synthesis Quote](#)

BenchChem

Our mission is to be the trusted global source of essential and advanced chemicals, empowering scientists and researchers to drive progress in science and industry.

Contact

Address: 3281 E Guasti Rd

Ontario, CA 91761, United States

Phone: (601) 213-4426

Email: info@benchchem.com