

Fmoc-Asp(OBzl)-OH molecular weight and formula.

Author: BenchChem Technical Support Team. **Date:** December 2025

Compound of Interest

Compound Name: Fmoc-Asp-OBzl

Cat. No.: B557530

[Get Quote](#)

Technical Guide: Fmoc-Asp(OBzl)-OH

Audience: Researchers, scientists, and drug development professionals.

This document provides a technical overview of N- α -Fmoc-L-aspartic acid β -benzyl ester, commonly referred to as Fmoc-Asp(OBzl)-OH. It is a widely used amino acid derivative in solid-phase peptide synthesis (SPPS).

Core Properties

Fmoc-Asp(OBzl)-OH is a derivative of the amino acid aspartic acid.^[1] It is specifically designed for use in Fmoc-based peptide synthesis, a common method for artificially creating peptides.^[1] The molecule incorporates two key protecting groups: the fluorenylmethyloxycarbonyl (Fmoc) group on the α -amine and a benzyl (Bzl) group on the side-chain carboxyl group. This dual protection allows for the sequential and controlled addition of amino acids during peptide chain elongation.

Physicochemical Data

The quantitative properties of Fmoc-Asp(OBzl)-OH are summarized in the table below. This data is essential for experimental design, including reaction stoichiometry and analytical characterization.

Property	Value	References
Molecular Formula	C ₂₆ H ₂₃ NO ₆	[2]
Molecular Weight	445.46 g/mol	
CAS Number	86060-84-6	
Appearance	White to light yellow crystalline powder	
Melting Point	120-130 °C	
Solubility	Soluble in methanol	
Storage Temperature	2-8°C	

Molecular Structure and Functionality

The structure of Fmoc-Asp(OBzl)-OH is defined by three key chemical moieties that dictate its function in peptide synthesis. The relationship between these components is illustrated below.

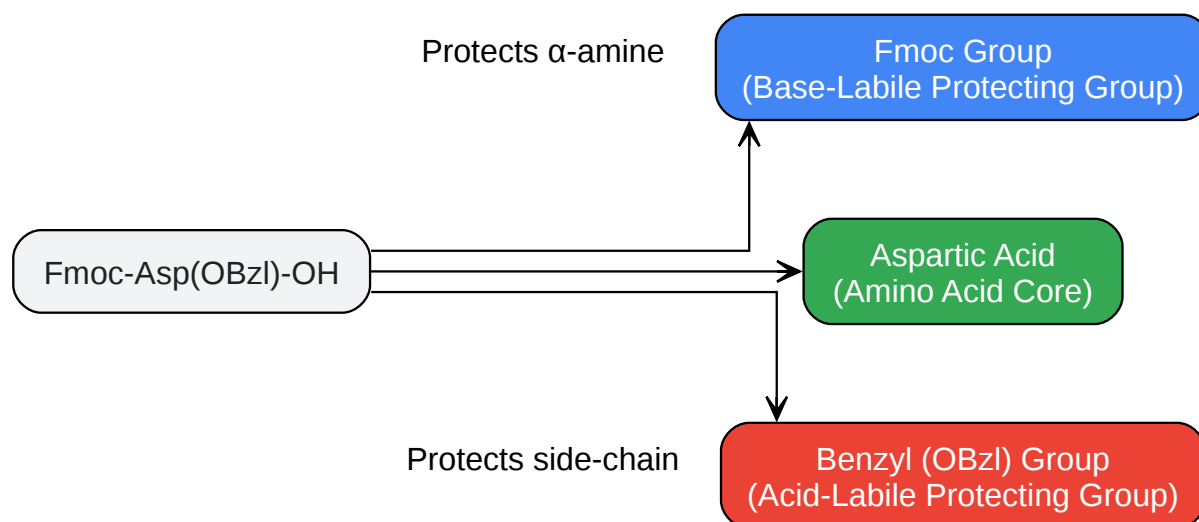

[Click to download full resolution via product page](#)

Caption: Logical diagram of Fmoc-Asp(OBzl)-OH's functional components.

Experimental Applications

General Protocol for use in Solid-Phase Peptide Synthesis (SPPS):

Fmoc-Asp(OBzl)-OH is a standard building block for introducing an aspartic acid residue into a peptide sequence using an automated peptide synthesizer or manual SPPS techniques. A generalized workflow is as follows:

- **Deprotection:** The N-terminal Fmoc group of the resin-bound growing peptide chain is removed using a basic solution, typically 20% piperidine in a solvent like dimethylformamide (DMF).
- **Activation & Coupling:** The carboxylic acid of Fmoc-Asp(OBzl)-OH is activated using a coupling reagent (e.g., HBTU, HATU) in the presence of a base (e.g., DIPEA). This activated amino acid is then added to the deprotected peptide-resin to form a new peptide bond.
- **Washing:** The resin is thoroughly washed with solvent to remove excess reagents and by-products.
- **Chain Elongation:** These steps are repeated for each subsequent amino acid in the desired sequence.
- **Final Cleavage:** Once the peptide synthesis is complete, the peptide is cleaved from the resin, and the side-chain protecting groups (like the benzyl group on aspartic acid) are removed simultaneously, typically using a strong acid cocktail (e.g., trifluoroacetic acid).

The workflow for a single coupling cycle in SPPS is visualized below.

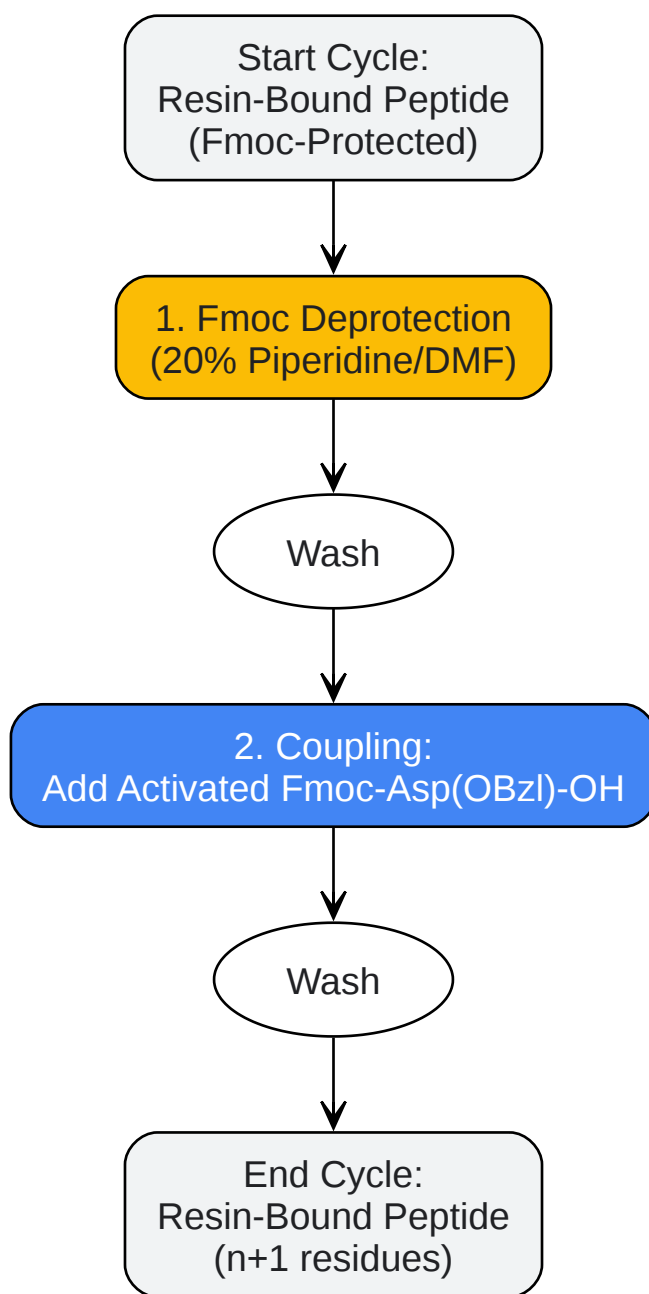

[Click to download full resolution via product page](#)

Caption: Workflow for a single amino acid coupling step in Fmoc SPPS.

Need Custom Synthesis?

BenchChem offers custom synthesis for rare earth carbides and specific isotopic labeling.

Email: info@benchchem.com or [Request Quote Online](#).

References

- 1. Buy Fmoc-Asp(OBzl)-OH | 86060-84-6 [smolecule.com]
- 2. Fmoc-Asp(OBzl)-OH | lookchem [lookchem.com]
- To cite this document: BenchChem. [Fmoc-Asp(OBzl)-OH molecular weight and formula.]. BenchChem, [2025]. [Online PDF]. Available at: [https://www.benchchem.com/product/b557530#fmoc-asp-obzl-oh-molecular-weight-and-formula]

Disclaimer & Data Validity:

The information provided in this document is for Research Use Only (RUO) and is strictly not intended for diagnostic or therapeutic procedures. While BenchChem strives to provide accurate protocols, we make no warranties, express or implied, regarding the fitness of this product for every specific experimental setup.

Technical Support: The protocols provided are for reference purposes. Unsure if this reagent suits your experiment? [[Contact our Ph.D. Support Team for a compatibility check](#)]

Need Industrial/Bulk Grade? [Request Custom Synthesis Quote](#)

BenchChem

Our mission is to be the trusted global source of essential and advanced chemicals, empowering scientists and researchers to drive progress in science and industry.

Contact

Address: 3281 E Guasti Rd
Ontario, CA 91761, United States
Phone: (601) 213-4426
Email: info@benchchem.com