

Fexagratinib solubility issues and solutions

Author: BenchChem Technical Support Team. **Date:** December 2025

Compound of Interest

Compound Name: *Fexagratinib*

Cat. No.: *B612004*

[Get Quote](#)

Fexagratinib Technical Support Center

This technical support center provides researchers, scientists, and drug development professionals with comprehensive guidance on the solubility of **Fexagratinib** (also known as AZD4547), a potent and selective inhibitor of the fibroblast growth factor receptor (FGFR) tyrosine kinase family.^{[1][2]} Here you will find troubleshooting guides, frequently asked questions, detailed experimental protocols, and visual diagrams to assist in your experiments.

Frequently Asked Questions (FAQs)

Q1: What is the known solubility of **Fexagratinib** in common laboratory solvents?

A1: **Fexagratinib** exhibits high solubility in Dimethyl Sulfoxide (DMSO).^{[3][4]} For many in vitro assays, DMSO is the recommended solvent for preparing stock solutions. Quantitative data for solubility in various solvents is summarized in the table below.

Q2: My **Fexagratinib** precipitated when I diluted my DMSO stock solution in aqueous media. What should I do?

A2: Precipitation upon dilution of a DMSO stock in aqueous buffers (like PBS or cell culture media) is a common issue for hydrophobic compounds. To address this, consider the following:

- Use of Surfactants or Co-solvents: For in vivo and some in vitro applications, a co-solvent system is often necessary. Formulations including PEG300 and a surfactant like Tween-80 can help maintain solubility in aqueous solutions.^{[3][4]}

- Lowering the Final Concentration: The final concentration of **Fexagratinib** in your aqueous medium may be exceeding its solubility limit. Try working with a lower final concentration.
- Sonication: Gentle sonication can sometimes help to redissolve small amounts of precipitate.
- Fresh Solution Preparation: Always prepare fresh working solutions from your DMSO stock immediately before use to minimize the chances of precipitation over time.[3]

Q3: What is the mechanism of action for **Fexagratinib**?

A3: **Fexagratinib** is a selective inhibitor of FGFR1, 2, and 3.[5] It binds to the tyrosine kinase domain of these receptors, which inhibits the downstream signaling pathways that are crucial for cell proliferation, differentiation, and survival in many cancer types.[5][6]

Troubleshooting Guide

Issue	Potential Cause	Recommended Solution
Fexagratinib powder will not dissolve in my chosen solvent.	The solvent may not be appropriate, or the concentration is too high.	Fexagratinib is highly soluble in DMSO.[3] For other solvents, refer to the solubility data table. If using DMSO, ensure it is fresh, as moisture-absorbing DMSO can reduce solubility.[3]
Cloudiness or precipitation observed in cell culture media after adding Fexagratinib stock.	The aqueous solubility limit has been exceeded. The final concentration of DMSO may also be too high for your cells.	Prepare an intermediate dilution in a co-solvent mixture (e.g., PEG300 and Tween-80) before adding to the final aqueous solution.[3] See the detailed protocol below. Ensure the final DMSO concentration is compatible with your cell line (typically <0.5%).
Inconsistent experimental results.	This could be due to incomplete dissolution or precipitation of Fexagratinib in the assay medium.	Always ensure your stock and working solutions are clear and free of any visible precipitate before use. Prepare fresh working solutions for each experiment.[3]

Quantitative Solubility Data

Solvent	Concentration	Notes
DMSO	93 mg/mL (200.61 mM)	Use of fresh DMSO is recommended as it can absorb moisture, which reduces solubility.[3]
DMSO (with ultrasonic)	125 mg/mL	Sonication can aid in dissolving the compound at higher concentrations.[7]
In vivo formulation 1	5.0 mg/mL	10% DMSO, 40% PEG300, 5% Tween-80, 45% Saline.[2]
In vivo formulation 2	5.0 mg/mL	4% DMSO, 30% PEG300, 5% Tween-80, 61% ddH ₂ O.[3][4]

Experimental Protocols

Protocol 1: Preparation of a 10 mM Fexagratinib Stock Solution in DMSO

- Weighing: Accurately weigh the required amount of **Fexagratinib** powder (Molar Mass: 463.58 g/mol).[1]
- Dissolution: Add the appropriate volume of fresh, anhydrous DMSO to the powder to achieve a 10 mM concentration.
- Mixing: Vortex the solution until the **Fexagratinib** is completely dissolved. Gentle warming or sonication can be used to aid dissolution if necessary.
- Storage: Aliquot the stock solution into smaller volumes to avoid repeated freeze-thaw cycles and store at -20°C or -80°C for long-term stability.

Protocol 2: Preparation of a Fexagratinib Working Solution for In Vivo Studies

This protocol provides an example for preparing a 1 mL working solution. Adjust volumes as needed for your experimental requirements.

- **Start with Stock:** Begin with a concentrated stock solution of **Fexagratinib** in DMSO (e.g., 125 mg/mL).[\[3\]](#)
- **Add Co-solvent:** In a sterile microcentrifuge tube, add 300 μ L of PEG300 to 40 μ L of the 125 mg/mL **Fexagratinib** DMSO stock. Mix thoroughly until the solution is clear.[\[3\]](#)
- **Add Surfactant:** To the mixture from step 2, add 50 μ L of Tween-80. Mix again until the solution is clear.[\[3\]](#)
- **Final Dilution:** Add 610 μ L of sterile ddH₂O or saline to the tube to bring the final volume to 1 mL. Mix thoroughly.[\[3\]](#)
- **Use Immediately:** It is recommended to use this freshly prepared solution for optimal results.[\[3\]](#)

Visual Diagrams

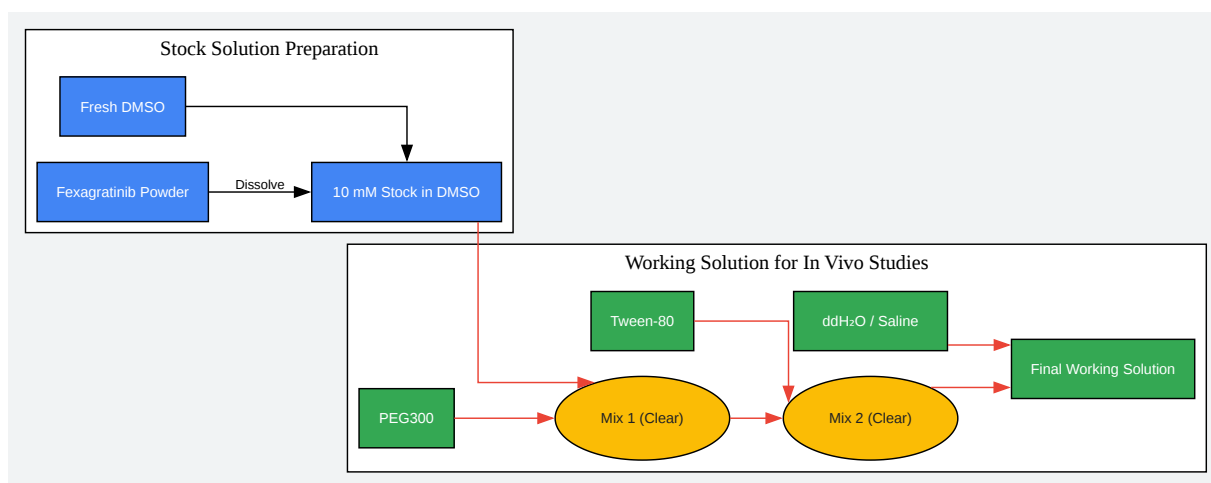

[Click to download full resolution via product page](#)

Caption: Workflow for preparing **Fexagratinib** solutions.

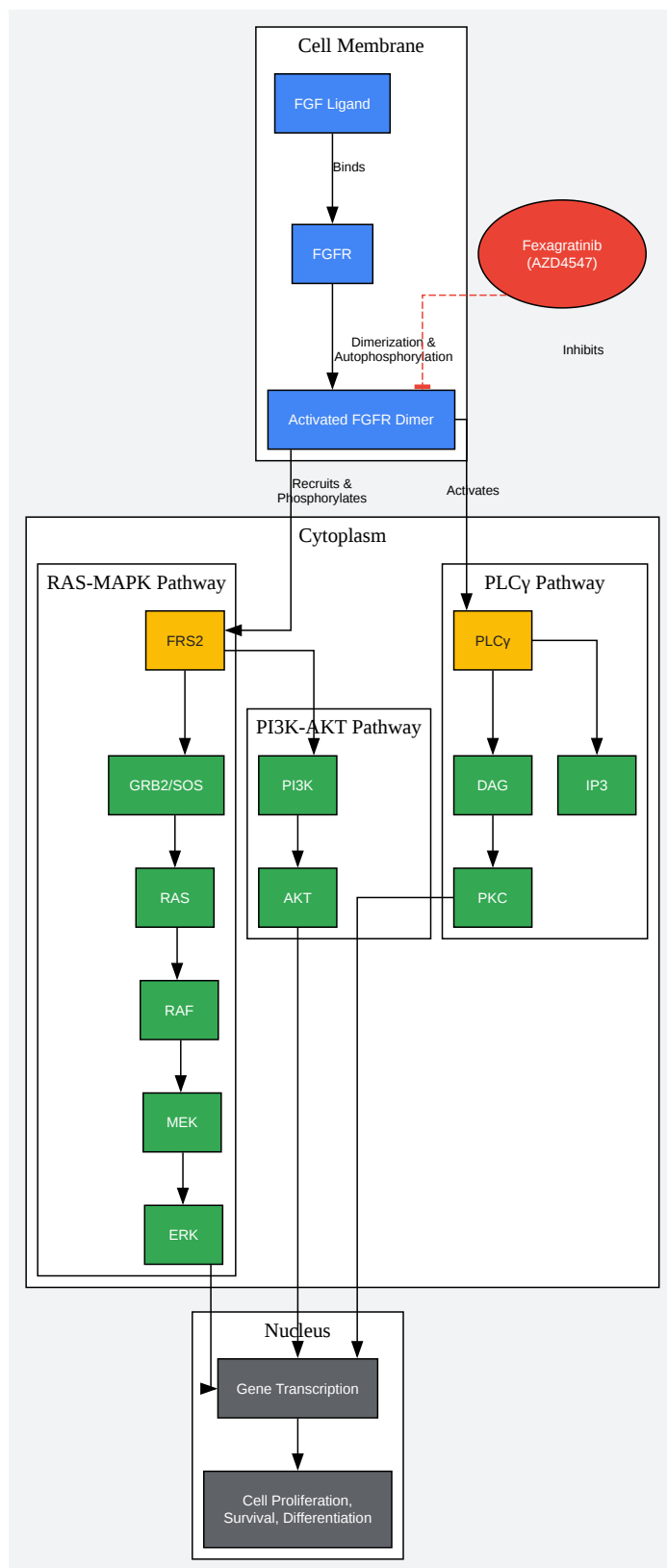

[Click to download full resolution via product page](#)

Caption: **Fexagratinib** inhibits the FGFR signaling pathway.

Need Custom Synthesis?

BenchChem offers custom synthesis for rare earth carbides and specific isotopic labeling.

Email: info@benchchem.com or [Request Quote Online](#).

References

- 1. The Fibroblast Growth Factor signaling pathway - PMC [pmc.ncbi.nlm.nih.gov]
- 2. medchemexpress.com [medchemexpress.com]
- 3. researchgate.net [researchgate.net]
- 4. selleckchem.com [selleckchem.com]
- 5. researchgate.net [researchgate.net]
- 6. researchgate.net [researchgate.net]
- 7. immunomart.com [immunomart.com]
- To cite this document: BenchChem. [Fexagratinib solubility issues and solutions]. BenchChem, [2025]. [Online PDF]. Available at: [https://www.benchchem.com/product/b612004#fexagratinib-solubility-issues-and-solutions]

Disclaimer & Data Validity:

The information provided in this document is for Research Use Only (RUO) and is strictly not intended for diagnostic or therapeutic procedures. While BenchChem strives to provide accurate protocols, we make no warranties, express or implied, regarding the fitness of this product for every specific experimental setup.

Technical Support: The protocols provided are for reference purposes. Unsure if this reagent suits your experiment? [[Contact our Ph.D. Support Team for a compatibility check](#)]

Need Industrial/Bulk Grade? [Request Custom Synthesis Quote](#)

BenchChem

Our mission is to be the trusted global source of essential and advanced chemicals, empowering scientists and researchers to drive progress in science and industry.

Contact

Address: 3281 E Guasti Rd

Ontario, CA 91761, United States

Phone: (601) 213-4426

Email: info@benchchem.com