

Experimental validation of thiophene-based materials for electrochromic devices.

Author: BenchChem Technical Support Team. **Date:** December 2025

Compound of Interest

Compound Name: Thiophene

Cat. No.: B3422377

[Get Quote](#)

A Comparative Guide to Thiophene-Based Materials for Electrochromic Devices

For researchers, scientists, and professionals in drug development, the selection of appropriate electrochromic materials is critical for the advancement of smart glass technologies, displays, and other optoelectronic applications. **Thiophene**-based polymers have emerged as a prominent class of electrochromic materials due to their high contrast ratios, fast switching speeds, and tunable colors. This guide provides an objective comparison of the performance of various **thiophene**-based materials with other organic and inorganic alternatives, supported by experimental data and detailed methodologies.

Performance Comparison of Electrochromic Materials

The efficacy of an electrochromic material is determined by several key performance indicators. These include the optical contrast (ΔT), which is the change in transmittance between the colored and bleached states; the switching speed, which measures the time taken for this transition; the coloration efficiency (η), a measure of the change in optical density per unit of charge injected; and the cycling stability, which indicates the material's durability over repeated switching cycles.

The following tables summarize the electrochromic performance of selected **thiophene**-based polymers and their common alternatives. It is important to note that the performance metrics

can be influenced by the fabrication method, device architecture, and the electrolyte used.

Material	Optical Contrast (ΔT) at λ_{max}	Switching Time (s)	Coloration Efficiency (η) (cm^2/C) at λ_{max}	Cycling Stability (% retention after cycles)
Thiophene-Based Polymers				
Poly(3,4-ethylenedioxythiophene) (PEDOT)	~41% at 632 nm[1]	< 2 (coloring), < 2 (bleaching)	100-200	Good
Poly(3-hexylthiophene) (P3HT)	High	-	-	Good
Poly(thieno[3,2-b]thiophene) (PTT)	35% at 700 nm[2]	1.0 s[2]	94 cm^2/C [2]	Excellent, <5% ΔT reduction after 1000 s[2]
Poly(ProDOT-Et ₂)	-	-	-	No significant decay after 400 cycles[3]
Alternative Organic Polymers				
Polyaniline (PANI)	-	-	50.0 cm^2/C [4]	Loses most charge storage after 350 cycles[4]
Inorganic Materials				
Tungsten Oxide (WO ₃)	>85%	Slow	36.3 cm^2/C [4]	Good

Experimental Protocols

Accurate and reproducible characterization of electrochromic materials is essential for their evaluation. The following are detailed methodologies for key experiments.

Cyclic Voltammetry (CV)

Cyclic voltammetry is employed to study the electrochemical behavior of the material, including its oxidation and reduction potentials.

Procedure:

- A three-electrode setup is used, comprising a working electrode (the electrochromic film on a conductive substrate), a counter electrode (e.g., platinum wire), and a reference electrode (e.g., Ag/AgCl).
- The electrodes are immersed in an electrolyte solution (e.g., 0.1 M LiClO₄ in propylene carbonate).
- A potentiostat is used to apply a potential that is swept linearly between two set points, and the resulting current is measured.
- The scan rate (e.g., 50 mV/s) is kept constant.
- The resulting voltammogram provides information on the redox processes of the material.

Spectroelectrochemistry

This technique combines UV-Vis spectroscopy with electrochemistry to monitor the changes in the optical properties of the material as a function of the applied potential.

Procedure:

- The electrochromic device is placed in the light path of a UV-Vis spectrophotometer.
- A potentiostat is used to apply a specific potential to the device.
- The UV-Vis spectrum is recorded at each potential step to measure the change in transmittance or absorbance.

- This allows for the determination of the optical contrast (ΔT) and the identification of the absorption maxima (λ_{max}) in the different redox states.

Switching Time Measurement

The switching time is the time required for the electrochromic material to change from its colored to its bleached state (and vice versa).

Procedure:

- A square wave potential is applied to the electrochromic device, alternating between the potentials required for the colored and bleached states.
- The transmittance at a specific wavelength (usually λ_{max}) is monitored over time using a spectrophotometer.
- The coloring time (τ_c) is the time taken for the transmittance to change from 90% to 10% of the full modulation, and the bleaching time (τ_b) is the time for the reverse process.

Visualizing Experimental Workflows

To provide a clearer understanding of the experimental processes, the following diagrams have been generated using Graphviz.

Electrochromic Device Fabrication Workflow

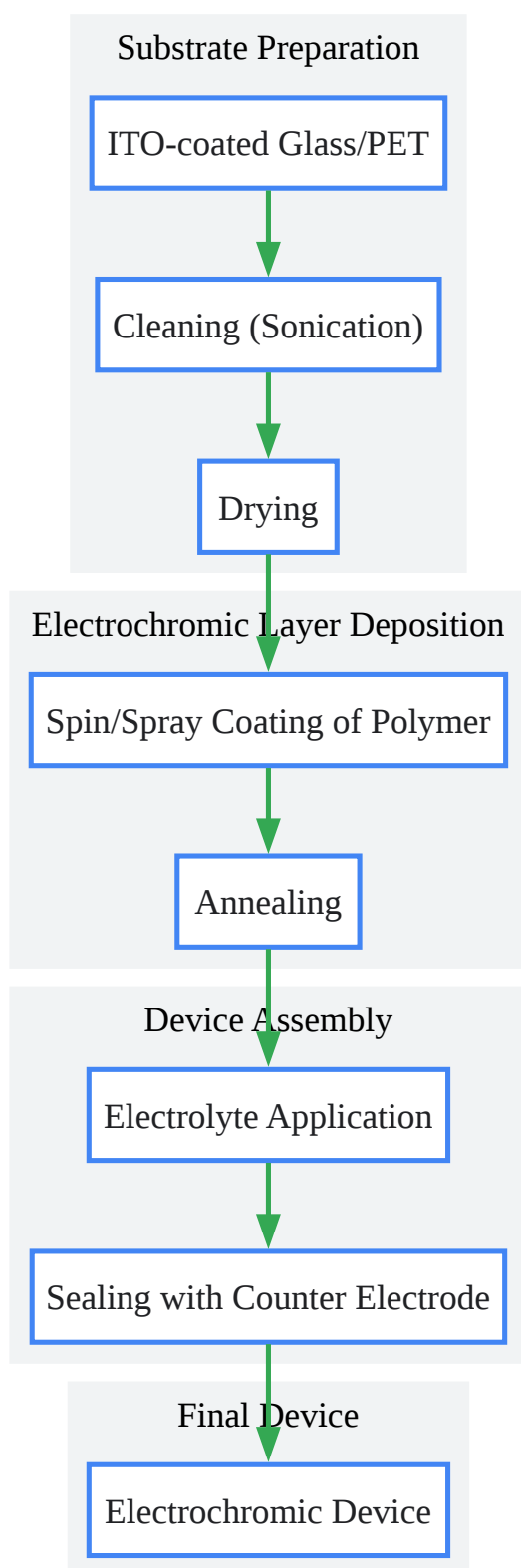

[Click to download full resolution via product page](#)

Fabrication workflow for a typical electrochromic device.

Spectroelectrochemistry Experimental Setup

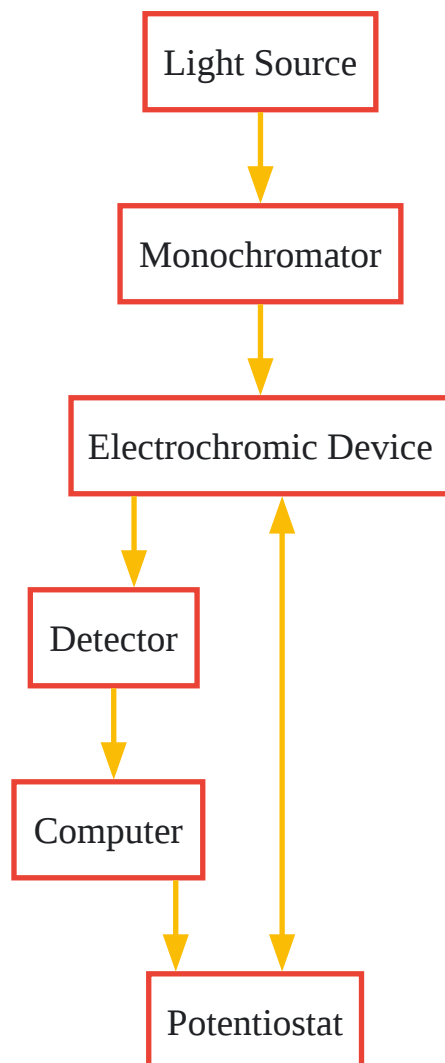

[Click to download full resolution via product page](#)

Schematic of a spectroelectrochemistry experimental setup.

Conclusion

Thiophene-based polymers offer a compelling combination of high performance and processability for electrochromic device applications. While inorganic materials like tungsten oxide can provide higher optical contrast, they often suffer from slower switching speeds. The choice of material will ultimately depend on the specific requirements of the application, including desired color, switching speed, and durability. The experimental protocols and workflows provided in this guide offer a foundation for the standardized evaluation of these promising materials.

Need Custom Synthesis?

BenchChem offers custom synthesis for rare earth carbides and specific isotopic labeling.

Email: info@benchchem.com or [Request Quote Online](#).

References

- 1. researchgate.net [researchgate.net]
- 2. f.oaes.cc [f.oaes.cc]
- 3. pubs.acs.org [pubs.acs.org]
- 4. researchgate.net [researchgate.net]
- To cite this document: BenchChem. [Experimental validation of thiophene-based materials for electrochromic devices.]. BenchChem, [2025]. [Online PDF]. Available at: [https://www.benchchem.com/product/b3422377#experimental-validation-of-thiophene-based-materials-for-electrochromic-devices]

Disclaimer & Data Validity:

The information provided in this document is for Research Use Only (RUO) and is strictly not intended for diagnostic or therapeutic procedures. While BenchChem strives to provide accurate protocols, we make no warranties, express or implied, regarding the fitness of this product for every specific experimental setup.

Technical Support: The protocols provided are for reference purposes. Unsure if this reagent suits your experiment? [[Contact our Ph.D. Support Team for a compatibility check](#)]

Need Industrial/Bulk Grade? [Request Custom Synthesis Quote](#)

BenchChem

Our mission is to be the trusted global source of essential and advanced chemicals, empowering scientists and researchers to drive progress in science and industry.

Contact

Address: 3281 E Guasti Rd

Ontario, CA 91761, United States

Phone: (601) 213-4426

Email: info@benchchem.com