

Evaluating the Synergistic Potential of (3S,4R)-PF-6683324 in Combination Therapies

Author: BenchChem Technical Support Team. **Date:** December 2025

Compound of Interest

Compound Name: (3S,4R)-PF-6683324

Cat. No.: B610054

[Get Quote](#)

For Researchers, Scientists, and Drug Development Professionals: An Objective Comparison Guide

(3S,4R)-PF-6683324 is a potent and selective small molecule inhibitor of Protein Tyrosine Kinase 6 (PTK6), also known as Breast Tumor Kinase (Brk). PTK6 is a non-receptor tyrosine kinase implicated in the progression of several cancers, including breast, ovarian, and prostate cancer. Its involvement in key oncogenic signaling pathways, such as the JAK/STAT, PI3K/AKT, and MAPK pathways, makes it a compelling target for anticancer therapies. This guide explores the synergistic potential of **(3S,4R)-PF-6683324** when combined with other therapeutic agents, providing a comprehensive overview of the preclinical evidence, experimental methodologies, and the underlying molecular mechanisms.

While direct combination studies involving **(3S,4R)-PF-6683324** are not yet extensively published, compelling preclinical data from studies on other selective PTK6 inhibitors provide a strong rationale for its use in synergistic combination regimens. Notably, research has demonstrated that inhibition of PTK6 can sensitize cancer cells to conventional chemotherapies, suggesting a promising avenue for future clinical investigation with **(3S,4R)-PF-6683324**.

Synergistic Effects with Chemotherapeutic Agents in Triple-Negative Breast Cancer (TNBC)

A pivotal study investigated the synergistic effects of a potent PTK6 small molecule inhibitor in combination with standard-of-care chemotherapies, paclitaxel and doxorubicin, in mesenchymal triple-negative breast cancer (TNBC) models. The findings from this research provide a strong proof-of-concept for the potential of **(3S,4R)-PF-6683324** to enhance the efficacy of these cytotoxic agents.

The study revealed that pre-treatment with a PTK6 inhibitor significantly increased the sensitivity of TNBC cell lines and patient-derived xenograft (PDX) organoids to both paclitaxel and doxorubicin in 3D matrigel cultures.^[1] The synergistic nature of this interaction was quantitatively confirmed through the calculation of the Combination Index (CI), where a CI value of less than 1 indicates synergy.^[1]

Quantitative Analysis of Synergy

The following table summarizes the synergistic interactions observed between a PTK6 inhibitor and conventional chemotherapies in TNBC models.

Cell Line/Model	Combination	Effect	Combination Index (CI)	Reference
Mesenchymal TNBC Cell Lines	PTK6 Inhibitor + Paclitaxel	Increased Sensitivity	CI < 1 (Synergism)	[1]
Mesenchymal TNBC Cell Lines	PTK6 Inhibitor + Doxorubicin	Increased Sensitivity	CI < 1 (Synergism)	[1]
TNBC PDX Organoids	PTK6 Inhibitor + Paclitaxel	Increased Sensitivity	Synergistic	[1]
TNBC PDX Organoids	PTK6 Inhibitor + Doxorubicin	Increased Sensitivity	Synergistic	[1]

In vivo studies using TNBC PDX models further corroborated these findings. While the PTK6 inhibitor or paclitaxel alone only modestly suppressed tumor growth, the combination treatment led to a dramatic suppression of both tumor volume and growth rate, highlighting the potent in vivo synergy.^[1]

Unraveling the Mechanism of Synergy: PTK6, SNAIL, and EMT

The synergistic effect of PTK6 inhibition with chemotherapy is rooted in the modulation of the Epithelial-Mesenchymal Transition (EMT) program, a key driver of tumor progression, metastasis, and drug resistance. PTK6 has been identified as a promoter of EMT in mesenchymal TNBC by preventing the degradation of SNAIL, a critical EMT-inducing transcription factor.[1]

The proposed mechanism of synergy is as follows:

- **PTK6 Inhibition:** Treatment with a PTK6 inhibitor, such as **(3S,4R)-PF-6683324**, leads to the suppression of PTK6 kinase activity.
- **SNAIL Destabilization:** This inhibition results in the destabilization and subsequent degradation of the SNAIL protein.
- **EMT Reversal:** The reduction in SNAIL levels leads to a partial reversal of the EMT phenotype, characterized by the upregulation of epithelial markers like E-cadherin.
- **Chemosensitization:** This reversal of EMT renders the cancer cells more susceptible to the cytotoxic effects of chemotherapeutic agents like paclitaxel and doxorubicin.

Gene ontology analysis of TNBC tumors treated with a PTK6 inhibitor revealed significant differential expression of genes involved in the extracellular matrix, cell migration, cell cycle, and microtubule activity, further supporting the role of PTK6 in modulating processes related to chemotherapy resistance.[1]

Signaling Pathways and Experimental Workflows

To visually represent the intricate molecular interactions and experimental processes, the following diagrams have been generated using Graphviz.

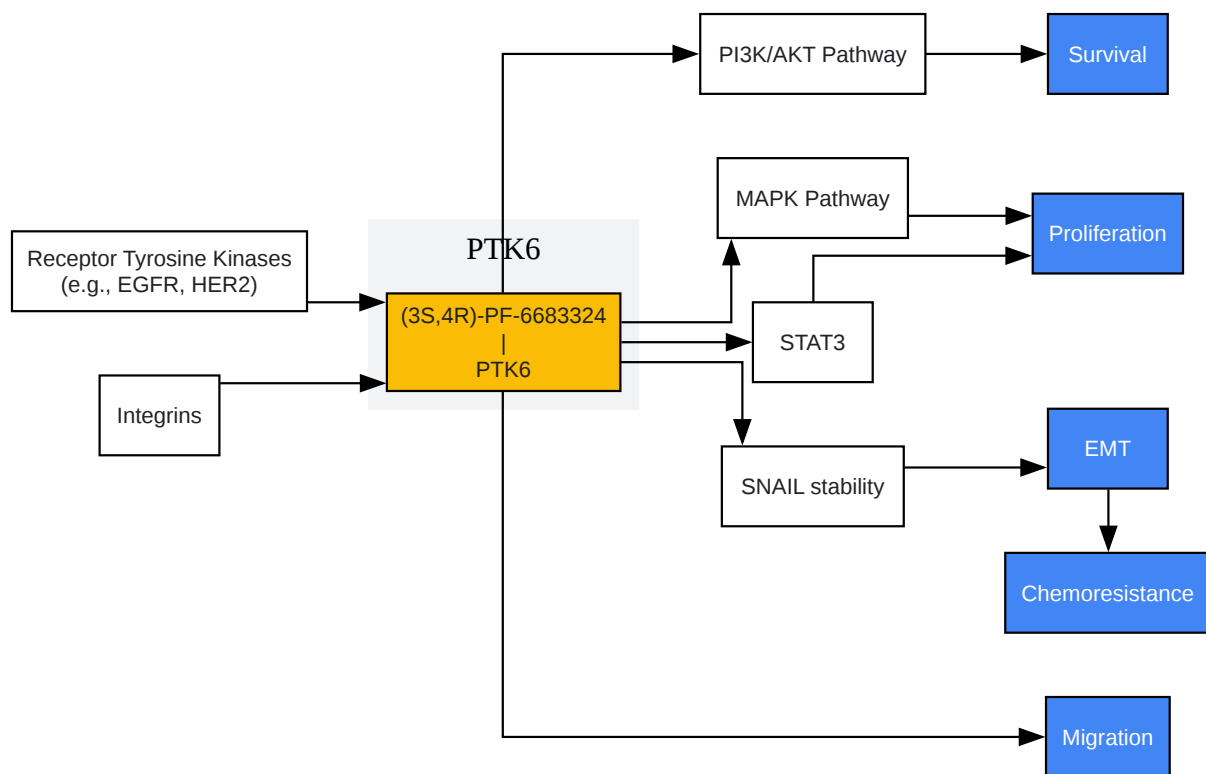

[Click to download full resolution via product page](#)

Caption: PTK6 signaling pathway and its downstream effects.

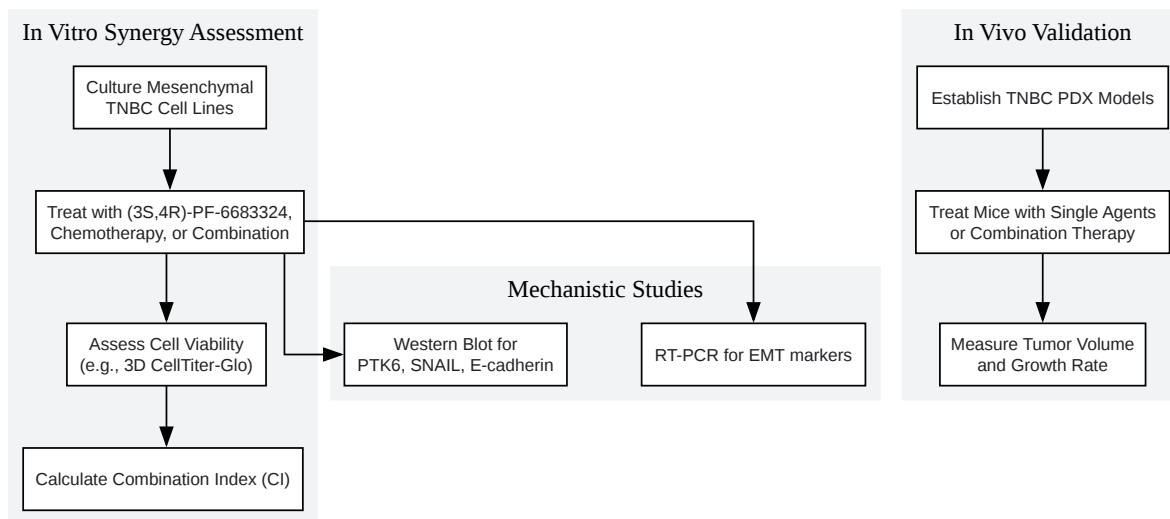

[Click to download full resolution via product page](#)

Caption: Experimental workflow for evaluating synergy.

Experimental Protocols

Detailed methodologies are crucial for the reproducibility and validation of scientific findings. Below are the key experimental protocols adapted from studies evaluating the synergy of PTK6 inhibitors.

Cell Viability Assay in 3D Culture

- **Cell Seeding:** Mesenchymal TNBC cell lines or organoids generated from TNBC PDX tumors are seeded in a 3D matrigel culture system.
- **Drug Treatment:** Cells are treated with varying concentrations of the PTK6 inhibitor, the chemotherapeutic agent (paclitaxel or doxorubicin), or the combination of both.
- **Incubation:** The cultures are incubated for a specified period to allow for drug action.

- **Viability Assessment:** Cell viability is assessed using a 3D-compatible assay such as CellTiter-Glo, which measures ATP levels as an indicator of metabolically active cells.[1]
- **Data Analysis:** The dose-response curves for each agent and the combination are generated. The Combination Index (CI) is calculated using the Chou-Talalay method to determine synergy ($CI < 1$), additivity ($CI = 1$), or antagonism ($CI > 1$).

In Vivo Synergy Studies in PDX Models

- **Model Establishment:** TNBC patient-derived xenograft (PDX) models are established in immunocompromised mice.
- **Treatment Groups:** Mice are randomized into different treatment groups: vehicle control, PTK6 inhibitor alone, paclitaxel alone, and the combination of the PTK6 inhibitor and paclitaxel.[1]
- **Drug Administration:** The drugs are administered according to a predetermined schedule and dosage.
- **Tumor Monitoring:** Tumor volume and growth rate are monitored regularly throughout the study.
- **Data Analysis:** Tumor growth curves for each treatment group are plotted and statistically analyzed to determine the significance of the combination therapy compared to single-agent treatments.

Western Blot Analysis

- **Cell Lysis:** TNBC cells treated with the PTK6 inhibitor are lysed to extract total protein.
- **Protein Quantification:** The protein concentration of the lysates is determined using a standard protein assay.
- **SDS-PAGE and Transfer:** Equal amounts of protein are separated by SDS-PAGE and transferred to a PVDF membrane.
- **Immunoblotting:** The membrane is probed with primary antibodies specific for PTK6, SNAIL, and E-cadherin, followed by incubation with appropriate HRP-conjugated secondary

antibodies.

- Detection: The protein bands are visualized using an enhanced chemiluminescence (ECL) detection system.

Conclusion and Future Directions

The preclinical evidence strongly suggests that inhibiting PTK6, a key player in cancer cell signaling, can effectively sensitize triple-negative breast cancer cells to conventional chemotherapy. The mechanism underlying this synergy, involving the reversal of EMT through the destabilization of SNAIL, provides a solid biological rationale for this combination approach.

As a potent and selective PTK6 inhibitor, **(3S,4R)-PF-6683324** holds significant promise for use in combination therapies. Further preclinical studies are warranted to directly evaluate the synergistic effects of **(3S,4R)-PF-6683324** with a broader range of anticancer agents and in various cancer types where PTK6 is overexpressed. The insights gained from such studies will be instrumental in designing future clinical trials to validate the therapeutic potential of this promising combination strategy for patients with difficult-to-treat cancers.

Need Custom Synthesis?

BenchChem offers custom synthesis for rare earth carbides and specific isotopic labeling.

Email: info@benchchem.com or [Request Quote Online](#).

References

- 1. aacrjournals.org [aacrjournals.org]
- To cite this document: BenchChem. [Evaluating the Synergistic Potential of (3S,4R)-PF-6683324 in Combination Therapies]. BenchChem, [2025]. [Online PDF]. Available at: [<https://www.benchchem.com/product/b610054#evaluating-synergistic-effects-of-3s-4r-pf-6683324-with-other-drugs>]

Disclaimer & Data Validity:

The information provided in this document is for Research Use Only (RUO) and is strictly not intended for diagnostic or therapeutic procedures. While BenchChem strives to provide

accurate protocols, we make no warranties, express or implied, regarding the fitness of this product for every specific experimental setup.

Technical Support: The protocols provided are for reference purposes. Unsure if this reagent suits your experiment? [[Contact our Ph.D. Support Team for a compatibility check](#)]

Need Industrial/Bulk Grade? [Request Custom Synthesis Quote](#)

BenchChem

Our mission is to be the trusted global source of essential and advanced chemicals, empowering scientists and researchers to drive progress in science and industry.

Contact

Address: 3281 E Guasti Rd

Ontario, CA 91761, United States

Phone: (601) 213-4426

Email: info@benchchem.com