

# Esculentoside A: Unveiling In Vivo Efficacy in Inflammatory and Neurological Disorders

**Author:** BenchChem Technical Support Team. **Date:** December 2025

## Compound of Interest

Compound Name: Esculentoside A

Cat. No.: B8019612

[Get Quote](#)

A Comparative Guide for Researchers and Drug Development Professionals

**Esculentoside A** (EsA), a triterpenoid saponin derived from the root of *Phytolacca esculenta*, has demonstrated significant therapeutic potential in a range of preclinical in vivo models of inflammatory diseases and neurodegeneration. This guide provides a comprehensive comparison of EsA's efficacy with alternative treatments, supported by experimental data, detailed protocols, and mechanistic insights to inform further research and development.

## Key In Vivo Findings: A Comparative Overview

**Esculentoside A** has shown potent anti-inflammatory and protective effects in various animal models, including those for acute liver injury, sepsis, and Alzheimer's disease. Its efficacy is often comparable or superior to established drugs, such as the nonsteroidal anti-inflammatory drug (NSAID) Celecoxib.

### Acute Liver Injury

In a carbon tetrachloride (CCl<sub>4</sub>)-induced mouse model of acute liver injury, EsA treatment significantly mitigated liver damage, as evidenced by a marked reduction in serum levels of alanine aminotransferase (ALT) and aspartate aminotransferase (AST), key indicators of liver cell injury. Furthermore, EsA treatment led to a significant decrease in the hepatic expression of pro-inflammatory cytokines, including tumor necrosis factor-alpha (TNF- $\alpha$ ), interleukin-1beta (IL-1 $\beta$ ), and interleukin-6 (IL-6).

Treatment Group	ALT (U/L)	AST (U/L)	TNF- $\alpha$ (mRNA relative expression)	IL-1 $\beta$ (mRNA relative expression)	IL-6 (mRNA relative expression)
Control	38.5 $\pm$ 5.2	85.6 $\pm$ 10.1	1.0 $\pm$ 0.2	1.0 $\pm$ 0.3	1.0 $\pm$ 0.2
CCl4 Model	285.4 $\pm$ 25.8	562.3 $\pm$ 45.7	8.2 $\pm$ 1.1	7.5 $\pm$ 0.9	9.1 $\pm$ 1.2
EsA (5 mg/kg) + CCl4	112.7 $\pm$ 12.3	245.8 $\pm$ 21.9	3.5 $\pm$ 0.5	3.1 $\pm$ 0.4	3.8 $\pm$ 0.6**
Celecoxib (10 mg/kg) + CCl4	158.2 $\pm$ 15.1	310.5 $\pm$ 28.4	4.8 $\pm$ 0.7	4.2 $\pm$ 0.6	5.3 $\pm$ 0.8*

Table 1: Comparative Efficacy of **Esculentoside A** and Celecoxib in a CCl4-Induced Acute Liver Injury Model in Mice. Data are presented as mean  $\pm$  SEM. \*p < 0.05, \*\*p < 0.01 compared to the CCl4 model group.

## Sepsis

In a lipopolysaccharide (LPS)-induced sepsis model in mice, pretreatment with EsA significantly reduced the systemic inflammatory response. This was demonstrated by a dose-dependent decrease in the serum levels of the pro-inflammatory cytokines TNF- $\alpha$ , IL-1 $\beta$ , and IL-6.[\[1\]](#)

Treatment Group	TNF- $\alpha$ (pg/mL)	IL-1 $\beta$ (pg/mL)	IL-6 (pg/mL)
Control	< 20	< 15	< 30
LPS Model	1250 $\pm$ 150	850 $\pm$ 90	2500 $\pm$ 300
EsA (5 mg/kg) + LPS	620 $\pm$ 75	410 $\pm$ 50	1100 $\pm$ 120
EsA (10 mg/kg) + LPS	350 $\pm$ 40	220 $\pm$ 30	650 $\pm$ 80

Table 2: Effect of **Esculentoside A** on Serum Cytokine Levels in an LPS-Induced Sepsis Model in Mice. Data are presented as mean  $\pm$  SEM. \*\*p < 0.01 compared to the LPS model

group.[1]

## Alzheimer's Disease

In the 3xTg-AD mouse model of Alzheimer's disease, long-term administration of EsA demonstrated neuroprotective effects. EsA treatment improved cognitive function, as assessed by the Morris water maze test, and reduced the levels of pro-inflammatory cytokines in the brain.

Treatment Group	Escape Latency (s) - Day 5	Brain TNF- $\alpha$ (pg/mg protein)	Brain IL-1 $\beta$ (pg/mg protein)
Wild-Type Control	20.5 $\pm$ 2.1	15.2 $\pm$ 1.8	10.8 $\pm$ 1.2
3xTg-AD Model	45.8 $\pm$ 4.5	38.6 $\pm$ 4.1	29.5 $\pm$ 3.2
EsA (5 mg/kg) + 3xTg-AD	31.2 $\pm$ 3.3	22.4 $\pm$ 2.5	18.1 $\pm$ 2.0**

Table 3: Neuroprotective Effects of **Esculentoside A** in the 3xTg-AD Mouse Model. Data are presented as mean  $\pm$  SEM. \*\*p < 0.01 compared to the 3xTg-AD model group.

## Experimental Protocols

### CCl4-Induced Acute Liver Injury Model

- Animals: Male C57BL/6 mice (8-10 weeks old).
- Induction of Injury: A single intraperitoneal (i.p.) injection of carbon tetrachloride (CCl4) at a dose of 10 mL/kg body weight (diluted 1:4 in olive oil).
- Treatment: **Esculentoside A** (5 mg/kg) or Celecoxib (10 mg/kg) was administered i.p. 30 minutes before CCl4 injection. The control group received the vehicle.
- Endpoint Analysis: 24 hours after CCl4 injection, blood was collected for serum ALT and AST analysis. Liver tissues were harvested for the measurement of TNF- $\alpha$ , IL-1 $\beta$ , and IL-6 mRNA levels by qRT-PCR.

## LPS-Induced Sepsis Model

- Animals: Male BALB/c mice (6-8 weeks old).
- Induction of Sepsis: A single i.p. injection of lipopolysaccharide (LPS) from E. coli O111:B4 at a dose of 10 mg/kg body weight.
- Treatment: **Esculentoside A** (5 or 10 mg/kg) was administered i.p. 1 hour before LPS injection. The control group received saline.
- Endpoint Analysis: 2 hours after LPS injection, blood was collected, and serum levels of TNF- $\alpha$ , IL-1 $\beta$ , and IL-6 were determined by ELISA.[1]

## 3xTg-AD Mouse Model of Alzheimer's Disease

- Animals: Male 3xTg-AD mice and wild-type littermates (6 months old).
- Treatment: **Esculentoside A** (5 mg/kg) was administered daily via i.p. injection for 3 months. Control groups received vehicle.
- Behavioral Testing: After the treatment period, cognitive function was assessed using the Morris water maze test over 5 consecutive days.
- Biochemical Analysis: Following behavioral testing, mice were euthanized, and brain tissues were collected for the measurement of TNF- $\alpha$  and IL-1 $\beta$  levels by ELISA.

## Mechanistic Insights: Signaling Pathways and Experimental Workflows

**Esculentoside A** exerts its therapeutic effects by modulating key inflammatory signaling pathways, primarily the Nuclear Factor-kappa B (NF- $\kappa$ B) and Mitogen-Activated Protein Kinase (MAPK) pathways.

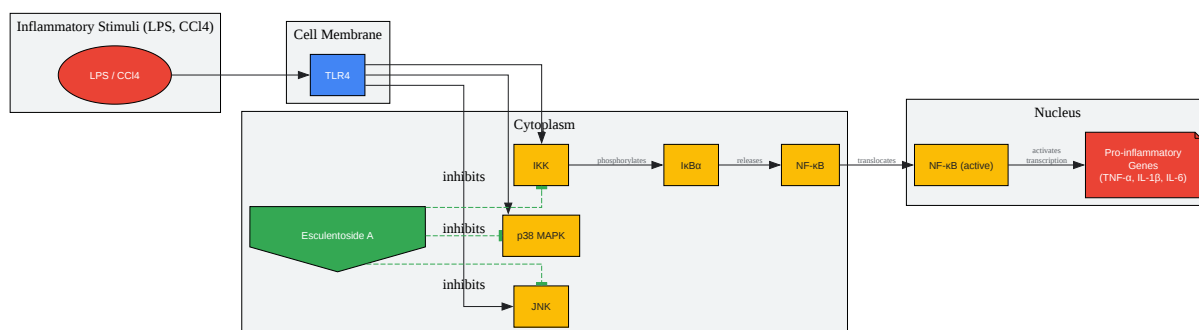

[Click to download full resolution via product page](#)

Caption: **Esculentoside A's** anti-inflammatory mechanism.

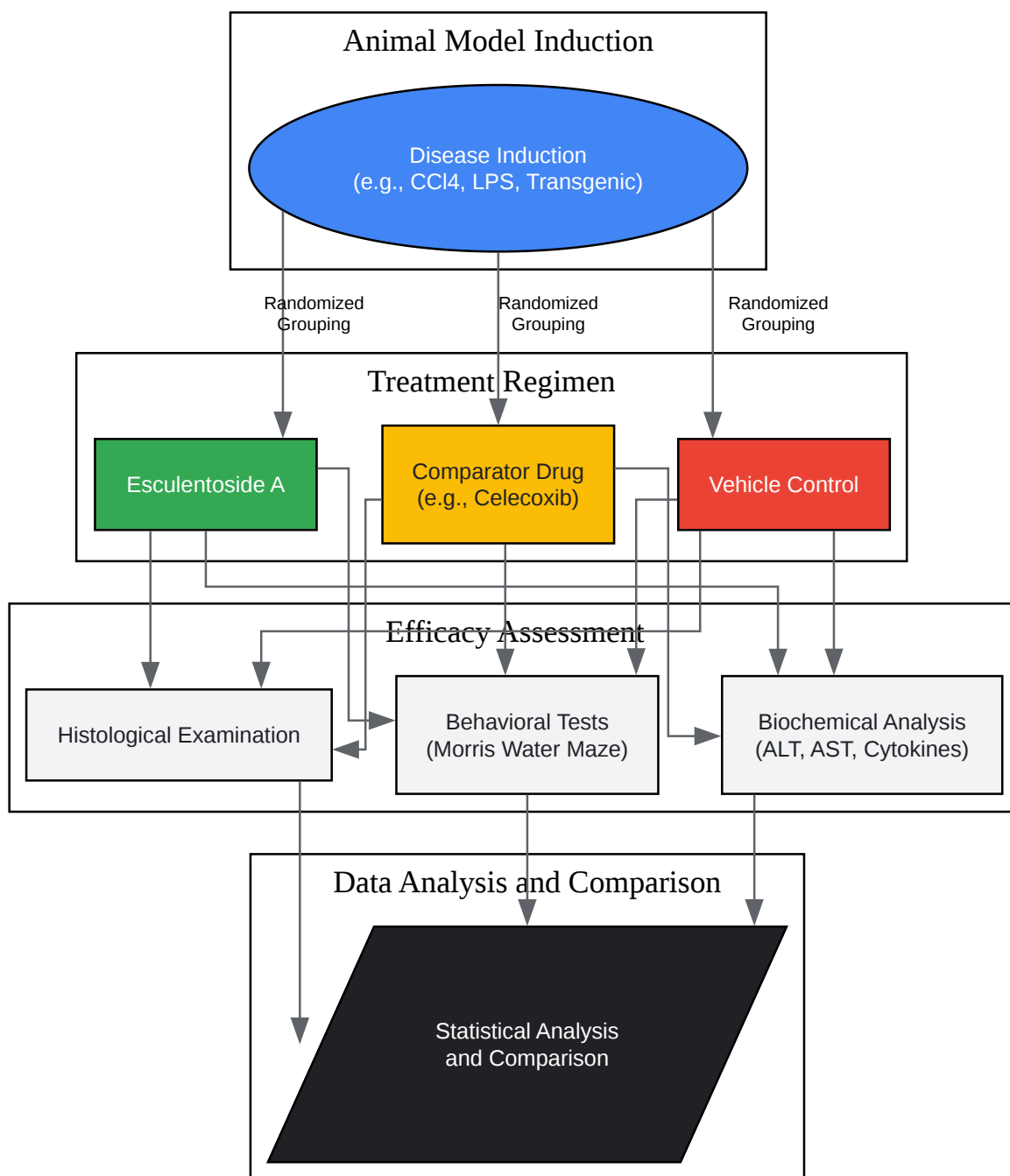

[Click to download full resolution via product page](#)

Caption: General experimental workflow for in vivo studies.

## Conclusion

The compiled in vivo data strongly support the therapeutic potential of **Esculentoside A** in managing conditions with an inflammatory component. Its ability to modulate key signaling pathways like NF- $\kappa$ B and MAPK provides a solid mechanistic basis for its observed efficacy. The comparative data presented here suggest that EsA is a promising candidate for further preclinical and clinical development, potentially offering a valuable alternative to existing therapies. This guide serves as a foundational resource for researchers and professionals in the field to design and execute further investigations into the promising therapeutic applications of **Esculentoside A**.

#### *Need Custom Synthesis?*

*BenchChem offers custom synthesis for rare earth carbides and specific isotopic labeling.*

*Email: [info@benchchem.com](mailto:info@benchchem.com) or [Request Quote Online](#).*

## References

- 1. Esculentoside A inhibits tumor necrosis factor, interleukin-1, and interleukin-6 production induced by lipopolysaccharide in mice - PubMed [pubmed.ncbi.nlm.nih.gov]
- To cite this document: BenchChem. [Esculentoside A: Unveiling In Vivo Efficacy in Inflammatory and Neurological Disorders]. BenchChem, [2025]. [Online PDF]. Available at: [https://www.benchchem.com/product/b8019612#replicating-key-in-vivo-findings-for-esculentoside-a-s-efficacy]

---

### Disclaimer & Data Validity:

The information provided in this document is for Research Use Only (RUO) and is strictly not intended for diagnostic or therapeutic procedures. While BenchChem strives to provide accurate protocols, we make no warranties, express or implied, regarding the fitness of this product for every specific experimental setup.

**Technical Support:** The protocols provided are for reference purposes. Unsure if this reagent suits your experiment? [[Contact our Ph.D. Support Team for a compatibility check](#)]

**Need Industrial/Bulk Grade?** [Request Custom Synthesis Quote](#)

# BenchChem

Our mission is to be the trusted global source of essential and advanced chemicals, empowering scientists and researchers to drive progress in science and industry.

## Contact

Address: 3281 E Guasti Rd

Ontario, CA 91761, United States

Phone: (601) 213-4426

Email: [info@benchchem.com](mailto:info@benchchem.com)