

DZ2002 Technical Support Center: Strategies to Improve Therapeutic Index

Author: BenchChem Technical Support Team. **Date:** December 2025

Compound of Interest

Compound Name: DZ2002

Cat. No.: B1254459

[Get Quote](#)

Welcome to the technical support center for **DZ2002**. This resource is designed to assist researchers, scientists, and drug development professionals in optimizing the therapeutic window of **DZ2002**. Below you will find troubleshooting guides and frequently asked questions (FAQs) to address common challenges encountered during your experiments.

Frequently Asked Questions (FAQs)

Q1: What is the known mechanism of action for **DZ2002**?

DZ2002 is an orally active, reversible, and low-cytotoxicity inhibitor of S-adenosyl-L-homocysteine hydrolase (SAHH) with a K_i of 17.9 nM.[1] Its mechanism of action involves the inhibition of SAHH, which leads to the accumulation of S-adenosyl-L-homocysteine (SAH). This accumulation, in turn, inhibits SAH-dependent methyltransferases, which are crucial for various cellular processes, including the regulation of gene expression. This activity gives **DZ2002** its significant immunosuppressive, anti-inflammatory, anti-fibrotic, and anti-angiogenic effects.[1]
[2]

Q2: What are the reported therapeutic effects of **DZ2002**?

DZ2002 has shown potent therapeutic effects in preclinical models of systemic sclerosis (SSc). It has been demonstrated to alleviate skin fibrosis by reducing collagen production and accumulation.[2] Furthermore, **DZ2002** suppresses the expression of pro-inflammatory cytokines and chemokines and reduces the infiltration of immune cells such as T-cells and macrophages in affected tissues.[2] It also improves vasculopathy by inhibiting the expression

of adhesion molecules.[2] A Phase I clinical trial for **DZ2002** as a potential therapy for systemic lupus erythematosus is underway.[3]

Q3: What is the therapeutic index and why is it important for **DZ2002**?

The therapeutic index (TI) is a quantitative measure of the safety of a drug. It is the ratio of the dose that produces toxicity in 50% of the population (TD50) to the dose that produces a clinically desired or effective response in 50% of the population (ED50).[4][5]

$$TI = TD50 / ED50$$

A higher therapeutic index indicates a wider margin between the toxic and effective doses, suggesting a safer drug.[5][6] For a drug like **DZ2002**, which is being developed for chronic autoimmune diseases, a favorable therapeutic index is crucial for long-term patient safety and tolerability.

Q4: What are the known toxicities or adverse effects of **DZ2002**?

While **DZ2002** is described as having "low-cytotoxicity," specific details regarding its toxicity profile from preclinical or clinical studies are not extensively published in the provided search results.[1] One study noted that at concentrations up to 2000 μM , **DZ2002** showed almost no toxicity in human microvascular endothelial cells (HMEC-1).[2] However, as with any potent inhibitor of a key enzyme like SAHH, potential for off-target effects or mechanism-based toxicities should be carefully evaluated.

Troubleshooting Guide

Problem 1: High variability in experimental results when determining the ED50 of **DZ2002**.

- Possible Cause 1: Animal model heterogeneity.
 - Troubleshooting Tip: Ensure that the age, weight, and genetic background of the animals used in your study are as uniform as possible. Stratify animals into treatment groups randomly to minimize bias.
- Possible Cause 2: Inconsistent drug administration.

- Troubleshooting Tip: **DZ2002** is orally active.[1] Ensure accurate and consistent dosing by using precise gavage techniques. For in vitro studies, verify the final concentration of **DZ2002** in the cell culture medium.
- Possible Cause 3: Pharmacokinetic variability.
 - Troubleshooting Tip: **DZ2002** is extensively converted to its acid metabolite, DZA, in rats. [3] The rate of this conversion can vary. Consider measuring the plasma concentrations of both **DZ2002** and DZA to correlate with the observed efficacy.

Problem 2: Unexpected toxicity observed at presumed therapeutic doses.

- Possible Cause 1: Off-target effects.
 - Troubleshooting Tip: Perform a comprehensive off-target screening assay to identify potential unintended molecular targets of **DZ2002**.
- Possible Cause 2: Accumulation of **DZ2002** or its metabolite.
 - Troubleshooting Tip: Conduct a multi-dose pharmacokinetic study to assess the accumulation of **DZ2002** and DZA over time. Adjust the dosing interval if necessary.
- Possible Cause 3: Drug-drug interactions.
 - Troubleshooting Tip: If using combination therapies, investigate the potential for metabolic or pharmacodynamic interactions between **DZ2002** and the co-administered drugs.

Strategies to Improve the Therapeutic Index of **DZ2002**

1. Combination Therapy

Combining **DZ2002** with another therapeutic agent can potentially enhance efficacy at lower, less toxic doses.

- Strategy: Pair **DZ2002** with a drug that has a different mechanism of action but targets a complementary pathway in the disease pathology. For example, in systemic sclerosis,

combining **DZ2002** with a standard-of-care immunosuppressant could be explored.

- Experimental Protocol:
 - Determine the ED50 of **DZ2002** and the combination agent individually in a relevant disease model.
 - Design a study with multiple dose combinations of **DZ2002** and the other agent.
 - Evaluate the therapeutic effect and toxicity of each combination.
 - Calculate the Combination Index (CI) to determine if the interaction is synergistic, additive, or antagonistic.

2. Targeted Drug Delivery

Delivering **DZ2002** specifically to the site of action can increase its local concentration and efficacy while minimizing systemic exposure and toxicity.

- Strategy: Encapsulate **DZ2002** in nanoparticles or liposomes that are targeted to inflamed tissues or specific cell types (e.g., activated fibroblasts or immune cells).
- Experimental Protocol:
 - Synthesize and characterize the targeted drug delivery system loaded with **DZ2002**.
 - Assess the in vitro uptake and efficacy of the targeted system in relevant cell types.
 - Conduct in vivo biodistribution studies to confirm targeting to the desired tissue.
 - Compare the therapeutic index of the targeted **DZ2002** formulation with that of free **DZ2002** in an animal model.

3. Pharmacokinetic Modification

Altering the absorption, distribution, metabolism, and excretion (ADME) properties of **DZ2002** can improve its safety profile.

- Strategy: Since **DZ2002** is rapidly metabolized to DZA, a potential strategy could be to develop a prodrug of **DZ2002** that is activated at the target site, or to co-administer it with an inhibitor of the enzyme responsible for its metabolism to prolong its half-life and potentially reduce the dose required.
- Experimental Protocol:
 - Identify the primary enzymes responsible for the conversion of **DZ2002** to DZA.
 - Screen for inhibitors of these enzymes.
 - Conduct pharmacokinetic studies in an animal model with **DZ2002** alone and in combination with the identified inhibitor.
 - Evaluate the impact on the therapeutic index.

Data Presentation

Table 1: Hypothetical Therapeutic Index Data for **DZ2002**

Compound	ED50 (mg/kg)	TD50 (mg/kg)	Therapeutic Index (TD50/ED50)
DZ2002	10	100	10
DZ2002 + Agent X	5	110	22
Targeted DZ2002	2	120	60

Visualizations

Signaling Pathway of **DZ2002**

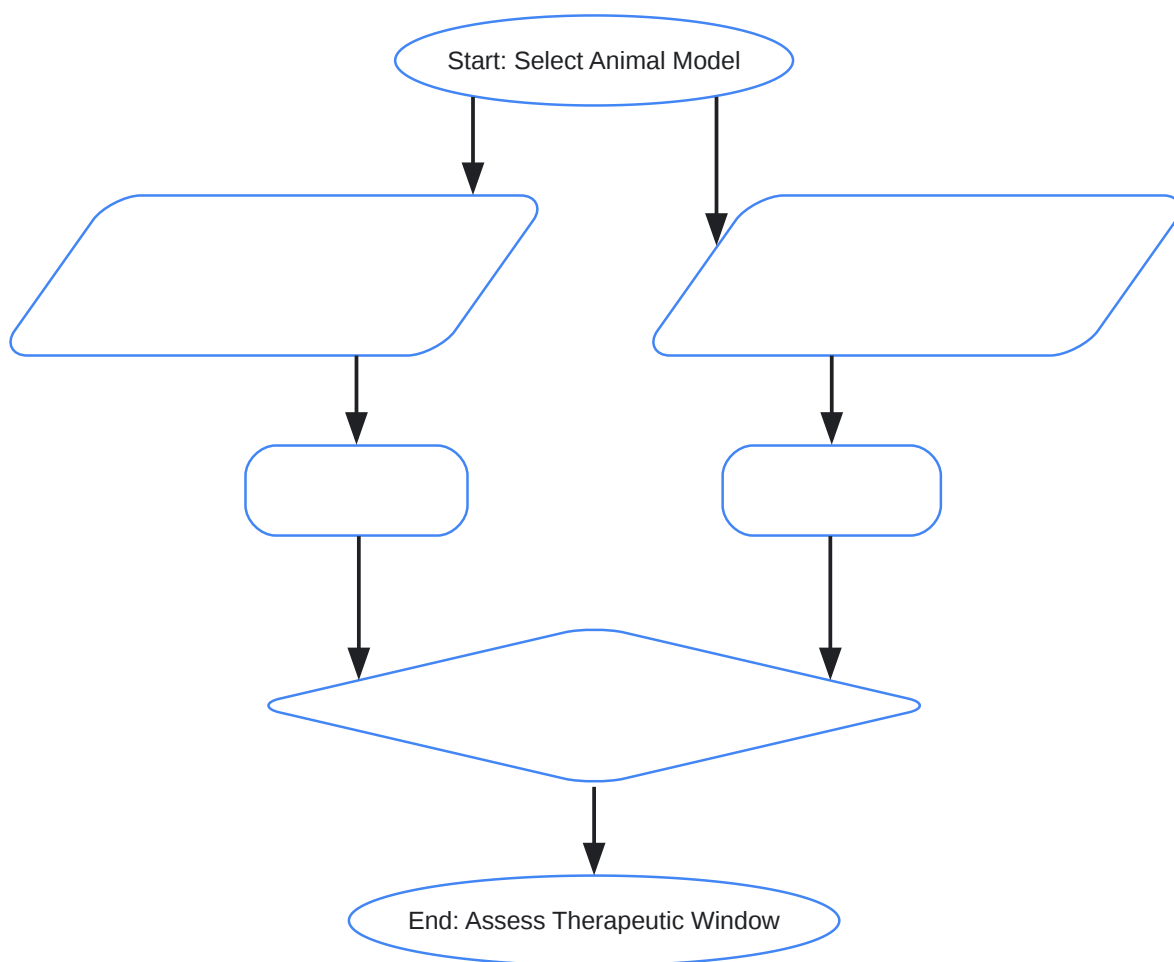
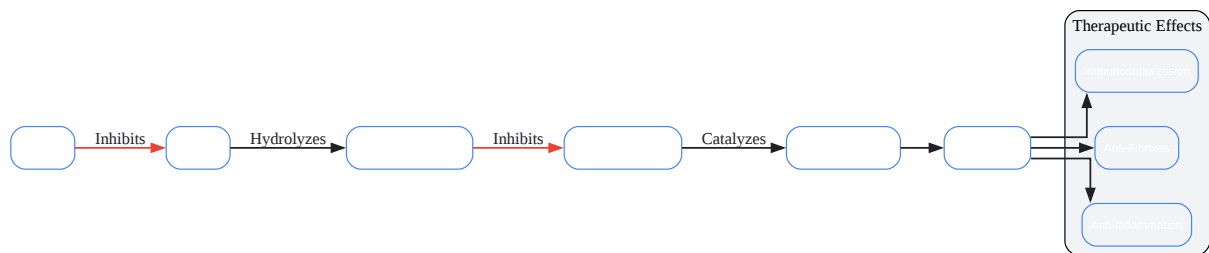

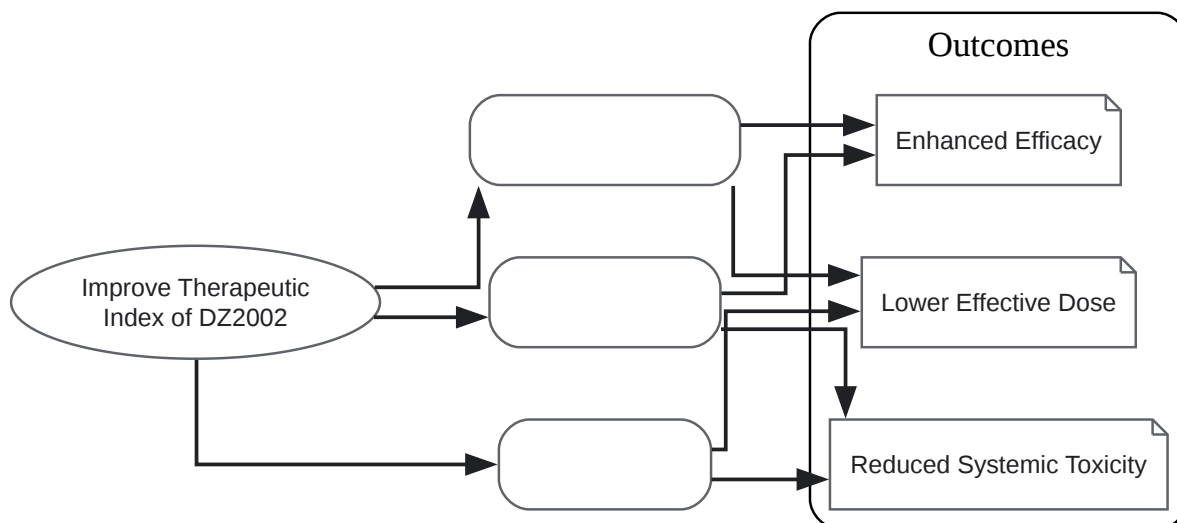

[Click to download full resolution via product page](#)

Need Custom Synthesis?

BenchChem offers custom synthesis for rare earth carbides and specific isotopic labeling.

Email: info@benchchem.com or [Request Quote Online](#).

References

- 1. DZ2002 | TargetMol [targetmol.com]
- 2. DZ2002 ameliorates fibrosis, inflammation, and vasculopathy in experimental systemic sclerosis models - PMC [pmc.ncbi.nlm.nih.gov]
- 3. Assay development for determination of DZ2002, a new reversible SAHH inhibitor, and its acid metabolite DZA in blood and application to rat pharmacokinetic study - PMC [pmc.ncbi.nlm.nih.gov]
- 4. Canadian Society of Pharmacology and Therapeutics (CSPT) - Therapeutic Index [pharmacologycanada.org]
- 5. youtube.com [youtube.com]
- 6. What is the therapeutic index of drugs? [medicalnewstoday.com]
- To cite this document: BenchChem. [DZ2002 Technical Support Center: Strategies to Improve Therapeutic Index]. BenchChem, [2025]. [Online PDF]. Available at:

[<https://www.benchchem.com/product/b1254459#strategies-to-improve-the-therapeutic-index-of-dz2002>]

Disclaimer & Data Validity:

The information provided in this document is for Research Use Only (RUO) and is strictly not intended for diagnostic or therapeutic procedures. While BenchChem strives to provide accurate protocols, we make no warranties, express or implied, regarding the fitness of this product for every specific experimental setup.

Technical Support: The protocols provided are for reference purposes. Unsure if this reagent suits your experiment? [[Contact our Ph.D. Support Team for a compatibility check](#)]

Need Industrial/Bulk Grade? [Request Custom Synthesis Quote](#)

BenchChem

Our mission is to be the trusted global source of essential and advanced chemicals, empowering scientists and researchers to drive progress in science and industry.

Contact

Address: 3281 E Guasti Rd
Ontario, CA 91761, United States
Phone: (601) 213-4426
Email: info@benchchem.com