

Cyclo(Ala-Gly): A Comparative Analysis of In Vitro Biological Activities

Author: BenchChem Technical Support Team. **Date:** December 2025

Compound of Interest

Compound Name: Cyclo(Ala-Gly)

Cat. No.: B051597

[Get Quote](#)

For Researchers, Scientists, and Drug Development Professionals

This guide provides a statistical analysis and comparison of the in vitro data available for **Cyclo(Ala-Gly)** and related cyclic dipeptides. The information is intended to support researchers and professionals in the fields of drug discovery and development by offering a concise overview of the current, albeit limited, state of knowledge regarding the biological effects of this simple cyclic dipeptide.

Comparative Analysis of In Vitro Cytotoxicity

Direct quantitative data for the biological activity of **Cyclo(Ala-Gly)** is most prominently available in the context of its cytotoxic effects against various cancer cell lines. In contrast, data for its anti-inflammatory and neuroprotective effects are less direct and often inferred from studies on structurally similar cyclic dipeptides.

Cyclic Dipeptide	Cell Line	Assay	Endpoint	Result
Cyclo(Ala-Gly)	A549 (Lung Carcinoma)	Cytotoxicity Assay	IC50	9.5 μ M[1]
HepG2 (Hepatocellular Carcinoma)	Cytotoxicity Assay	IC50	18.1 μ M[1]	
HT29 (Colon Adenocarcinoma)	Cytotoxicity Assay	IC50	Not specified, but cytotoxic	
Cyclo(His-Ala)	HT-29, MCF-7, HeLa	Growth Inhibition	% Inhibition at 100 μ M	Significant inhibition
Cyclo(His-Gly)	MCF-7	Growth Inhibition	% Inhibition at 100 μ M	Significant inhibition

In Vitro Anti-inflammatory and Neuroprotective Potential: A Comparative Overview

While specific quantitative in vitro data for the anti-inflammatory and neuroprotective effects of **Cyclo(Ala-Gly)** are not readily available in the reviewed literature, studies on related cyclic dipeptides provide valuable insights into its potential activities. These compounds share a core diketopiperazine structure, suggesting that **Cyclo(Ala-Gly)** may exhibit similar biological properties.

Potential Anti-inflammatory Activity

Cyclic dipeptides are known to possess anti-inflammatory properties. For instance, Cyclo(Gly-L-Pro) has been shown to suppress the release of the pro-inflammatory cytokine TNF- α , reduce the mRNA expression of IL-1 β and IL-6, and inhibit the production of nitric oxide (NO). [2] Another related compound, Cyclo(His-Pro), exerts anti-inflammatory effects by modulating the NF- κ B and Nrf2 signaling pathways.[3] Based on these findings, it is plausible that **Cyclo(Ala-Gly)** could also modulate inflammatory responses in vitro, a hypothesis that warrants experimental validation.

Potential Neuroprotective Activity

The neuroprotective potential of cyclic dipeptides is another area of active research. Cyclo(Gly-L-Pro) has demonstrated neuroprotective and immunostimulatory properties in animal models, enhancing memory and improving functional recovery.[2] Furthermore, the cyclic dipeptide Cyclo(Pro-Gly) has been investigated for its neuroprotective effects in the context of neurodegenerative disorders. These observations suggest that **Cyclo(Ala-Gly)** may also possess neuroprotective capabilities, potentially by mitigating neuronal damage or modulating signaling pathways relevant to neuronal survival.

Experimental Protocols

The following are detailed methodologies for key experiments typically cited in the in vitro analysis of cyclic dipeptides.

Cell Viability and Cytotoxicity Assay (MTT Assay)

- **Cell Seeding:** Plate cells in a 96-well plate at a density of 5×10^3 to 1×10^4 cells/well and incubate for 24 hours to allow for cell attachment.
- **Compound Treatment:** Treat the cells with various concentrations of **Cyclo(Ala-Gly)** or other test compounds and incubate for a specified period (e.g., 24, 48, or 72 hours).
- **MTT Addition:** Add MTT (3-(4,5-dimethylthiazol-2-yl)-2,5-diphenyltetrazolium bromide) solution to each well and incubate for 2-4 hours. During this time, viable cells with active mitochondrial dehydrogenases will convert the yellow MTT to purple formazan crystals.
- **Solubilization:** Add a solubilization solution (e.g., DMSO or isopropanol with HCl) to dissolve the formazan crystals.
- **Data Acquisition:** Measure the absorbance of the solution at a specific wavelength (typically 570 nm) using a microplate reader. The intensity of the purple color is directly proportional to the number of viable cells.
- **Statistical Analysis:** Calculate the half-maximal inhibitory concentration (IC₅₀) by plotting the percentage of cell viability against the logarithm of the compound concentration and fitting the data to a sigmoidal dose-response curve.

Nitric Oxide (NO) Production Assay (Griess Test)

- **Cell Culture and Stimulation:** Culture macrophages (e.g., RAW 264.7) in a 24-well plate. Pre-treat the cells with different concentrations of the test compound for 1 hour before stimulating with an inflammatory agent like lipopolysaccharide (LPS) for 24 hours.
- **Sample Collection:** Collect the cell culture supernatant.
- **Griess Reaction:** Mix an equal volume of the supernatant with Griess reagent (a mixture of sulfanilamide and N-(1-naphthyl)ethylenediamine dihydrochloride in phosphoric acid).
- **Incubation:** Allow the mixture to incubate at room temperature for 10-15 minutes to allow for the formation of a colored azo compound.
- **Data Acquisition:** Measure the absorbance at 540 nm using a microplate reader.
- **Quantification:** Determine the nitrite concentration in the samples by comparing the absorbance values to a standard curve generated with known concentrations of sodium nitrite.
- **Statistical Analysis:** Analyze the data for statistically significant differences in NO production between treated and untreated control groups.

Cytokine Release Assay (ELISA)

- **Cell Treatment:** Seed immune cells (e.g., peripheral blood mononuclear cells or macrophages) in a culture plate and treat them with the test compound and/or an inflammatory stimulus.
- **Supernatant Collection:** After the desired incubation period, collect the cell culture supernatant.
- **ELISA Procedure:**
 - Coat a 96-well ELISA plate with a capture antibody specific for the cytokine of interest (e.g., TNF- α , IL-6, IL-1 β).
 - Block the plate to prevent non-specific binding.

- Add the collected cell supernatants and standards to the wells.
- Add a detection antibody conjugated to an enzyme (e.g., horseradish peroxidase).
- Add a substrate that reacts with the enzyme to produce a measurable signal (e.g., colorimetric or chemiluminescent).
- Data Acquisition: Measure the signal using a microplate reader.
- Data Analysis: Calculate the concentration of the cytokine in the samples based on a standard curve.
- Statistical Analysis: Compare the cytokine levels in the treated groups to the control groups to determine the effect of the compound.

Signaling Pathways and Experimental Workflows

To visualize the potential mechanisms and experimental processes involved in studying **Cyclo(Ala-Gly)**, the following diagrams are provided.

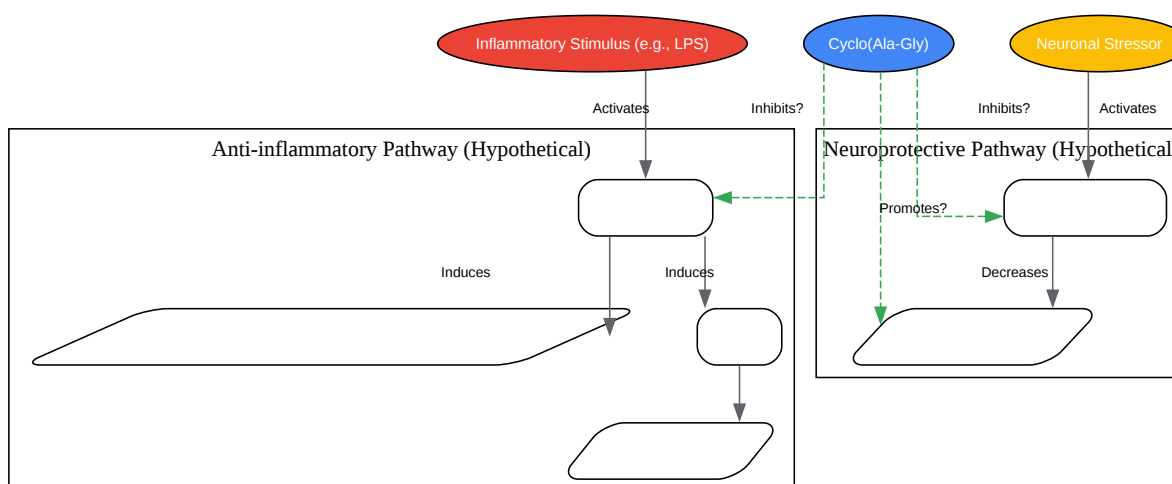
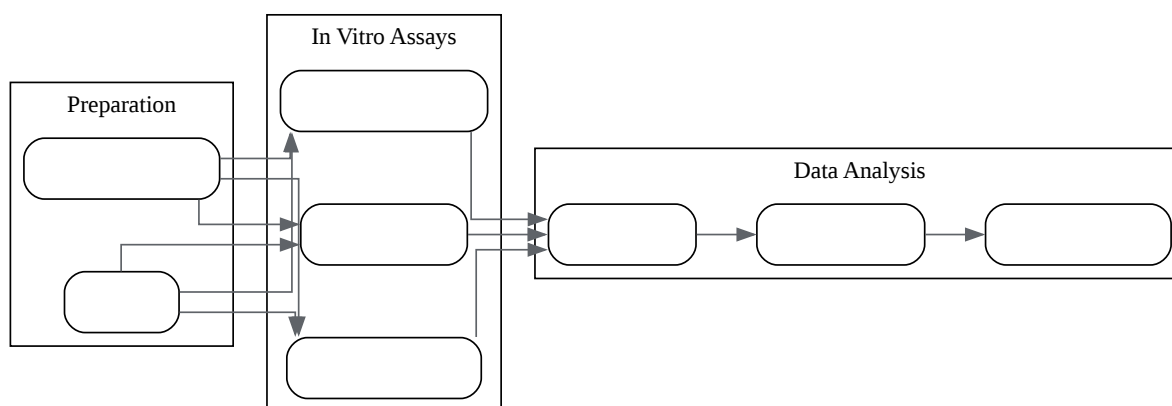

[Click to download full resolution via product page](#)

Need Custom Synthesis?

BenchChem offers custom synthesis for rare earth carbides and specific isotopic labeling.

Email: info@benchchem.com or [Request Quote Online](#).

References

- 1. medchemexpress.com [medchemexpress.com]
- 2. Cyclo(Gly-L-Pro) | Natural Product | TargetMol [targetmol.com]
- 3. Cyclo(His-Pro) exerts anti-inflammatory effects by modulating NF- κ B and Nrf2 signalling - PubMed [pubmed.ncbi.nlm.nih.gov]
- To cite this document: BenchChem. [Cyclo(Ala-Gly): A Comparative Analysis of In Vitro Biological Activities]. BenchChem, [2025]. [Online PDF]. Available at: [https://www.benchchem.com/product/b051597#statistical-analysis-of-in-vitro-data-for-cyclo-ala-gly-studies]

Disclaimer & Data Validity:

The information provided in this document is for Research Use Only (RUO) and is strictly not intended for diagnostic or therapeutic procedures. While BenchChem strives to provide accurate protocols, we make no warranties, express or implied, regarding the fitness of this product for every specific experimental setup.

Technical Support: The protocols provided are for reference purposes. Unsure if this reagent suits your experiment? [[Contact our Ph.D. Support Team for a compatibility check](#)]

Need Industrial/Bulk Grade? [Request Custom Synthesis Quote](#)

BenchChem

Our mission is to be the trusted global source of essential and advanced chemicals, empowering scientists and researchers to drive progress in science and industry.

Contact

Address: 3281 E Guasti Rd

Ontario, CA 91761, United States

Phone: (601) 213-4426

Email: info@benchchem.com