

Curindolizine's Mechanism of Action in Inflammatory Pathways: A Technical Guide

Author: BenchChem Technical Support Team. **Date:** December 2025

Compound of Interest

Compound Name: *Curindolizine*

Cat. No.: *B12418404*

[Get Quote](#)

For Researchers, Scientists, and Drug Development Professionals

Abstract

Curindolizine, a skeletally unprecedented indolizine alkaloid, has demonstrated notable anti-inflammatory properties. This technical guide provides an in-depth exploration of the proposed mechanism of action by which **Curindolizine** may modulate key inflammatory signaling pathways. While direct experimental evidence for **Curindolizine's** specific interactions with these pathways is currently limited, this document synthesizes the available data on its anti-inflammatory activity and outlines detailed experimental protocols to facilitate further investigation into its molecular targets. The primary focus is on the Nuclear Factor-kappa B (NF- κ B), Mitogen-Activated Protein Kinase (MAPK), and Janus Kinase/Signal Transducer and Activator of Transcription (JAK-STAT) signaling cascades, all of which are critical regulators of the inflammatory response. This guide is intended to serve as a valuable resource for researchers in the fields of pharmacology, immunology, and drug discovery.

Introduction to Curindolizine

Curindolizine is a unique indolizine alkaloid isolated from the white croaker-associated fungus *Curvularia* sp. IFB-Z10.[1] Structurally distinct from other known anti-inflammatory agents, **Curindolizine** has emerged as a compound of interest for its potential therapeutic applications in inflammatory diseases. Preliminary studies have shown that **Curindolizine** exhibits significant anti-inflammatory effects in cellular models of inflammation.[1]

Anti-Inflammatory Activity of Curindolizine

The anti-inflammatory potential of **Curindolizine** has been primarily demonstrated in lipopolysaccharide (LPS)-stimulated RAW 264.7 macrophages, a widely used in vitro model for studying inflammation. In this model, **Curindolizine** was found to inhibit the production of inflammatory mediators with a half-maximal inhibitory concentration (IC50) of $5.31 \pm 0.21 \mu\text{M}$. [1] This finding establishes **Curindolizine** as a potent anti-inflammatory agent and provides the basis for a deeper investigation into its mechanism of action.

Proposed Mechanism of Action in Inflammatory Pathways

Based on the known roles of key signaling pathways in inflammation and the observed anti-inflammatory activity of **Curindolizine**, this section outlines the proposed mechanisms through which this compound may exert its effects. It is important to note that these are hypothesized pathways and require direct experimental validation.

Inhibition of the NF- κ B Signaling Pathway

The NF- κ B pathway is a central regulator of inflammation, controlling the expression of numerous pro-inflammatory genes, including cytokines, chemokines, and adhesion molecules. It is proposed that **Curindolizine** may inhibit NF- κ B activation through the following steps:

- **Inhibition of I κ B α Phosphorylation and Degradation:** In resting cells, NF- κ B is sequestered in the cytoplasm by the inhibitor of κ B alpha (I κ B α). Upon stimulation with LPS, I κ B α is phosphorylated and subsequently degraded, allowing NF- κ B to translocate to the nucleus. **Curindolizine** may prevent this by inhibiting the I κ B kinase (IKK) complex, thereby stabilizing I κ B α .
- **Prevention of p65 Nuclear Translocation:** By preventing I κ B α degradation, **Curindolizine** would consequently block the nuclear translocation of the p65 subunit of NF- κ B.
- **Suppression of NF- κ B-mediated Gene Transcription:** With p65 retained in the cytoplasm, the transcription of NF- κ B target genes, such as those encoding for TNF- α , IL-6, and IL-1 β , would be suppressed.



[Click to download full resolution via product page](#)

Proposed inhibition of the NF-κB pathway by **Curindolizine**.

Modulation of the MAPK Signaling Pathway

The MAPK family, including p38, JNK, and ERK, plays a crucial role in the production of pro-inflammatory mediators. **Curindolizine** may exert its anti-inflammatory effects by inhibiting the phosphorylation of these key kinases.

- **Inhibition of p38, JNK, and ERK Phosphorylation:** Upon LPS stimulation, the phosphorylation of p38, JNK, and ERK is activated. **Curindolizine** may interfere with the upstream kinases responsible for their activation, leading to a reduction in their phosphorylated (active) forms.
- **Downregulation of Downstream Inflammatory Mediators:** The inhibition of MAPK phosphorylation would, in turn, suppress the expression and activity of downstream targets, including cyclooxygenase-2 (COX-2) and inducible nitric oxide synthase (iNOS), leading to decreased production of prostaglandins and nitric oxide, respectively.

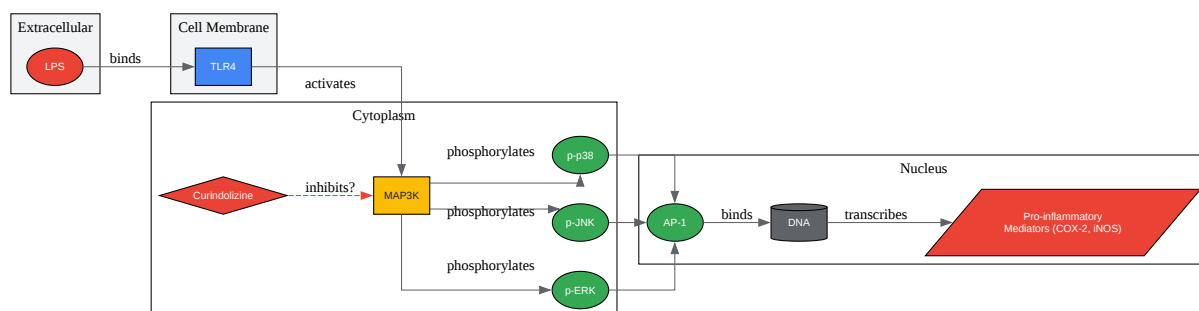

[Click to download full resolution via product page](#)

Proposed modulation of the MAPK pathway by **Curindolizine**.

Attenuation of the JAK-STAT Signaling Pathway

The JAK-STAT pathway is critical for transmitting signals from cytokine receptors to the nucleus, leading to the expression of genes involved in inflammation and immunity.

Curindolizine's anti-inflammatory action may involve the inhibition of this pathway.

- Inhibition of STAT3 Phosphorylation: Pro-inflammatory cytokines can activate the phosphorylation of STAT3. **Curindolizine** may inhibit the activity of Janus kinases (JAKs), which are responsible for phosphorylating STAT3.
- Suppression of STAT3-mediated Gene Expression: By preventing STAT3 phosphorylation, **Curindolizine** would block its dimerization and translocation to the nucleus, thereby inhibiting the transcription of STAT3-dependent pro-inflammatory genes.

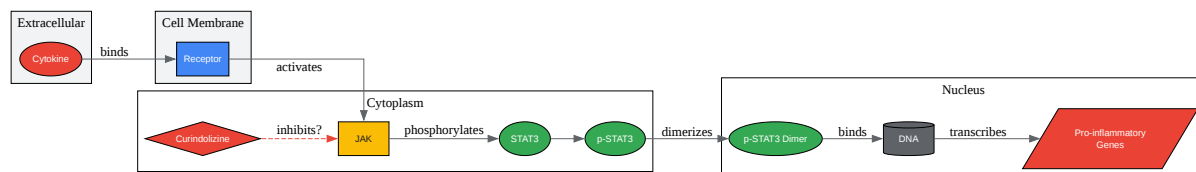

[Click to download full resolution via product page](#)

Need Custom Synthesis?

BenchChem offers custom synthesis for rare earth carbides and specific isotopic labeling.

Email: info@benchchem.com or [Request Quote Online](#).

References

- 1. Curindolizine, an Anti-Inflammatory Agent Assembled via Michael Addition of Pyrrole Alkaloids Inside Fungal Cells - PubMed [pubmed.ncbi.nlm.nih.gov]
- To cite this document: BenchChem. [Curindolizine's Mechanism of Action in Inflammatory Pathways: A Technical Guide]. BenchChem, [2025]. [Online PDF]. Available at: [https://www.benchchem.com/product/b12418404#curindolizine-mechanism-of-action-in-inflammatory-pathways]

Disclaimer & Data Validity:

The information provided in this document is for Research Use Only (RUO) and is strictly not intended for diagnostic or therapeutic procedures. While BenchChem strives to provide

accurate protocols, we make no warranties, express or implied, regarding the fitness of this product for every specific experimental setup.

Technical Support: The protocols provided are for reference purposes. Unsure if this reagent suits your experiment? [[Contact our Ph.D. Support Team for a compatibility check](#)]

Need Industrial/Bulk Grade? [Request Custom Synthesis Quote](#)

BenchChem

Our mission is to be the trusted global source of essential and advanced chemicals, empowering scientists and researchers to drive progress in science and industry.

Contact

Address: 3281 E Guasti Rd

Ontario, CA 91761, United States

Phone: (601) 213-4426

Email: info@benchchem.com