

Cudraflavone B vs. Quercetin: A Comparative Guide to Anticancer Effects

Author: BenchChem Technical Support Team. **Date:** December 2025

Compound of Interest

Compound Name: Cudraflavone B

Cat. No.: B15609472

[Get Quote](#)

For Researchers, Scientists, and Drug Development Professionals

Introduction

In the ongoing search for novel anticancer agents, flavonoids have emerged as a promising class of natural compounds. Among them, **Cudraflavone B** and Quercetin have garnered significant attention for their potent antiproliferative and pro-apoptotic activities across a range of cancer types. This guide provides a comprehensive comparison of the anticancer effects of **Cudraflavone B** and Quercetin, presenting experimental data, detailing methodologies, and visualizing key signaling pathways to aid researchers in their drug discovery and development efforts.

Quantitative Comparison of Anticancer Activity

The half-maximal inhibitory concentration (IC₅₀) is a critical measure of a compound's potency in inhibiting a specific biological process, such as cell proliferation. The following tables summarize the reported IC₅₀ values for **Cudraflavone B** and Quercetin in various cancer cell lines. While direct comparative studies are limited, this compilation allows for an indirect assessment of their relative efficacy.

Table 1: IC₅₀ Values of **Cudraflavone B** in Various Cancer Cell Lines

Cancer Cell Line	Cancer Type	IC50 (μM)	Citation
U87	Glioblastoma	10	[1]
U251	Glioblastoma	~20 (significant inhibition at 20 μM)	[1]
B16	Melanoma	>12 (effective lowest concentration)	[1]
Human Gastric Carcinoma	Gastric Cancer	>12 (effective lowest concentration)	[1]
Human Oral Cancer	Oral Cancer	>12 (effective lowest concentration)	[1]
RAW264.7	Macrophage (used in inflammation studies)	7.4 $\mu\text{g/mL}$	[2]

Table 2: IC50 Values of Quercetin in Various Cancer Cell Lines

Cancer Cell Line	Cancer Type	IC50 (μM)	Treatment Duration	Citation
T47D	Breast Cancer	50	48h	[3]
MCF-7	Breast Cancer	37	24h	[4]
MCF-7	Breast Cancer	13.7	Not Specified	[5]
MDA-MB-231	Breast Cancer	>100 (less sensitive)	24h	[4]
HT29	Colorectal Cancer	81.65	48h	[6]
A549	Lung Cancer	8.65 $\mu\text{g/mL}$	24h	[7]
A549	Lung Cancer	7.96 $\mu\text{g/mL}$	48h	[7]
A549	Lung Cancer	5.14 $\mu\text{g/mL}$	72h	[7]
H69	Lung Cancer	14.2 $\mu\text{g/mL}$	24h	[7]
H69	Lung Cancer	10.57 $\mu\text{g/mL}$	48h	[7]
H69	Lung Cancer	9.18 $\mu\text{g/mL}$	72h	[7]

Mechanisms of Anticancer Action

Both **Cudraflavone B** and Quercetin exert their anticancer effects through multifaceted mechanisms, primarily by inducing apoptosis (programmed cell death) and causing cell cycle arrest.

Induction of Apoptosis

Cudraflavone B triggers the mitochondrial apoptotic pathway.[8] This is characterized by the upregulation of pro-apoptotic proteins like p53, Bax, and cleaved caspase-3, and the downregulation of the anti-apoptotic protein Bcl-2.[8][9] Studies have shown that **Cudraflavone B** treatment leads to an increase in the sub-G1 cell population, a hallmark of apoptosis.[8] In human oral cancer cells, a concentration of 15 μM **Cudraflavone B** was sufficient to induce

apoptosis.[8] Furthermore, in glioblastoma cells, **Cudraflavone B** induces apoptosis through endoplasmic reticulum (ER) stress-induced autophagy.[1][10]

Quercetin also potently induces apoptosis in a wide array of cancer cells.[11][12] It can activate both the intrinsic (mitochondrial) and extrinsic (death receptor) pathways.[11] Quercetin treatment has been shown to increase the expression of Bax, cytochrome c, and caspases, while decreasing the expression of Bcl-2.[13] In triple-negative breast cancer cells, quercetin induces apoptosis through the modulation of Foxo3a signaling.[14] It has also been observed to increase the percentage of apoptotic cells in various cancer cell lines as demonstrated by Annexin V/PI staining.[11]

Cell Cycle Arrest

Cudraflavone B has been shown to induce cell cycle arrest, contributing to its antiproliferative effects. Treatment with **Cudraflavone B** can lead to the upregulation of cell cycle inhibitors like p21 and p27.[8]

Quercetin is well-documented to cause cell cycle arrest at different phases, including G1, S, and G2/M, depending on the cancer cell type.[15][16] It modulates the expression of key cell cycle regulatory proteins such as cyclins and cyclin-dependent kinases (CDKs).[15] For instance, in oral squamous carcinoma cells, quercetin induces G1 arrest.[16] In triple-negative breast cancer cells, it causes arrest in the S and G2/M phases.[14]

Signaling Pathways

The anticancer activities of **Cudraflavone B** and Quercetin are mediated by their modulation of various intracellular signaling pathways crucial for cancer cell survival and proliferation.

Cudraflavone B Signaling Pathways

Cudraflavone B has been shown to modulate the MAPK and NF-κB signaling pathways.[8] In human oral cancer cells, it activates p38 MAPK and ERK, which are involved in apoptosis induction.[8] It also influences the SIRT1 pathway.[8] In glioblastoma cells, **Cudraflavone B** activates the ER stress-related pathway and the PI3K/mTOR/LC3B signaling pathway, leading to autophagy-mediated apoptosis.[1]

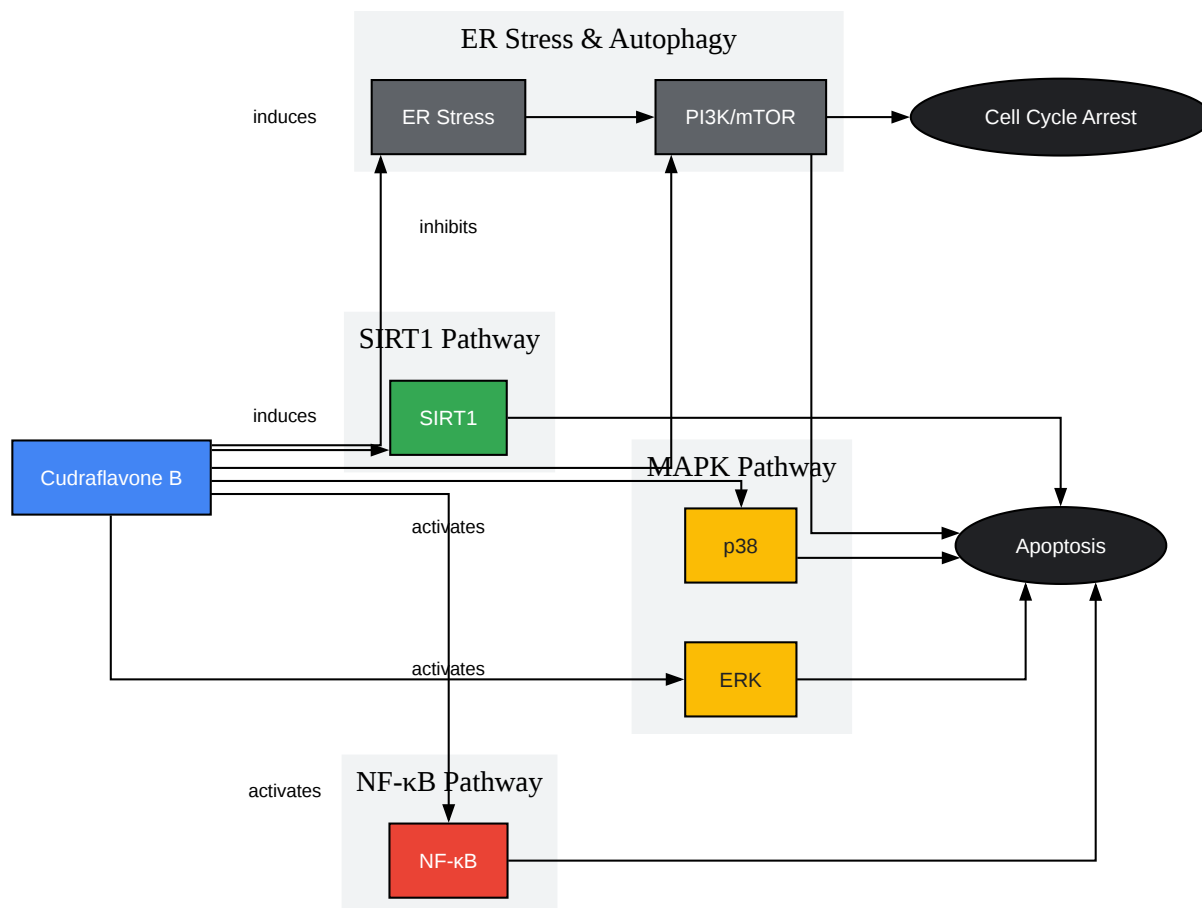

[Click to download full resolution via product page](#)

Cudraflavone B Signaling Pathways

Quercetin Signaling Pathways

Quercetin's anticancer effects are mediated through its interaction with multiple signaling pathways, including the PI3K/Akt and MAPK pathways.[17][18][19][20][21] By inhibiting the PI3K/Akt pathway, a key survival pathway in many cancers, quercetin promotes apoptosis.[19] It also modulates the MAPK pathway, which can lead to either cell survival or apoptosis

depending on the cellular context.[20] Furthermore, quercetin has been shown to influence the p53 and Wnt/ β -catenin signaling pathways.[15]

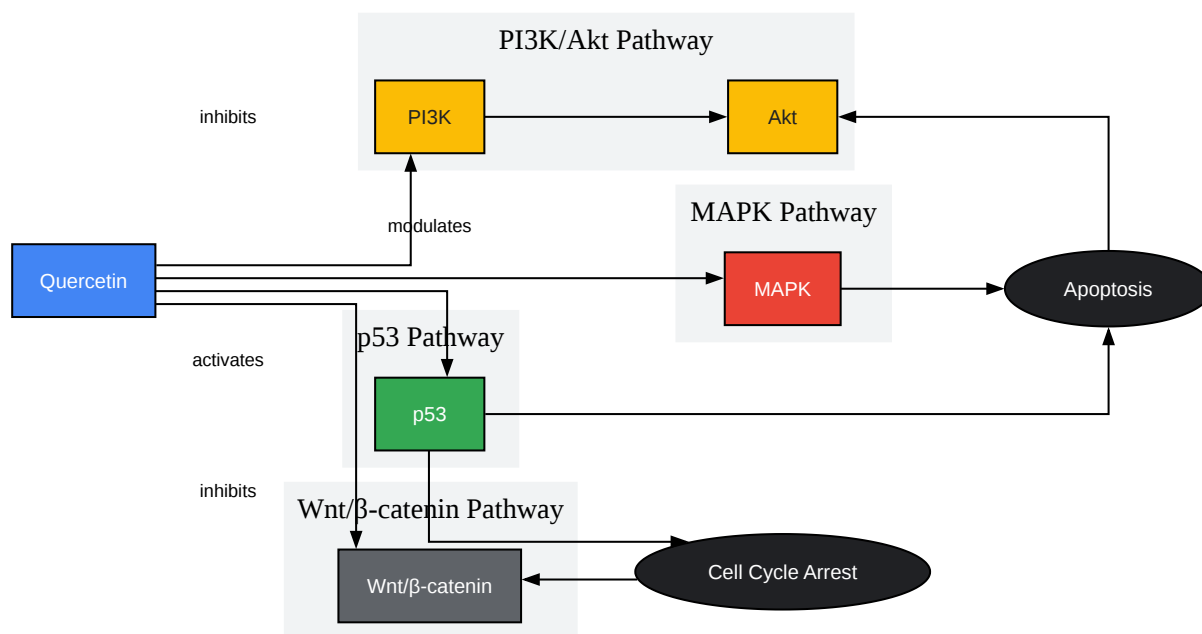

[Click to download full resolution via product page](#)

Quercetin Signaling Pathways

Experimental Protocols

This section provides detailed methodologies for key experiments commonly used to evaluate the anticancer effects of compounds like **Cudraflavone B** and Quercetin.

MTT Assay for Cell Viability

The MTT (3-(4,5-dimethylthiazol-2-yl)-2,5-diphenyltetrazolium bromide) assay is a colorimetric assay for assessing cell metabolic activity. NAD(P)H-dependent cellular oxidoreductase enzymes reflect the number of viable cells present.

Materials:

- Cancer cell lines
- Complete culture medium
- MTT solution (5 mg/mL in PBS)
- Dimethyl sulfoxide (DMSO) or other solubilizing agent
- 96-well plates
- Multichannel pipette
- Microplate reader

Procedure:

- Seed cells in a 96-well plate at a density of 5,000-10,000 cells/well and incubate for 24 hours.
- Treat the cells with various concentrations of **Cudraflavone B** or Quercetin and incubate for the desired time period (e.g., 24, 48, 72 hours). Include untreated cells as a control.
- After the incubation period, add 20 μ L of MTT solution to each well and incubate for 4 hours at 37°C.
- Carefully remove the medium and add 150 μ L of DMSO to each well to dissolve the formazan crystals.
- Shake the plate for 10 minutes to ensure complete dissolution.
- Measure the absorbance at 570 nm using a microplate reader.
- Calculate the percentage of cell viability relative to the untreated control.



[Click to download full resolution via product page](#)

MTT Assay Workflow

Flow Cytometry for Apoptosis Analysis (Annexin V/PI Staining)

This method distinguishes between viable, early apoptotic, late apoptotic, and necrotic cells.

Materials:

- Cancer cell lines
- Annexin V-FITC Apoptosis Detection Kit (containing Annexin V-FITC, Propidium Iodide (PI), and Binding Buffer)
- Phosphate-buffered saline (PBS)
- Flow cytometer

Procedure:

- Seed cells and treat with **Cudraflavone B** or Quercetin as described for the MTT assay.
- Harvest the cells (including floating cells in the medium) and wash twice with cold PBS.
- Resuspend the cells in 1X Binding Buffer at a concentration of 1×10^6 cells/mL.
- Transfer 100 μ L of the cell suspension to a flow cytometry tube.
- Add 5 μ L of Annexin V-FITC and 5 μ L of PI to the cell suspension.
- Gently vortex the cells and incubate for 15 minutes at room temperature in the dark.
- Add 400 μ L of 1X Binding Buffer to each tube.
- Analyze the cells by flow cytometry within one hour. Viable cells are Annexin V- and PI-negative; early apoptotic cells are Annexin V-positive and PI-negative; late apoptotic/necrotic cells are both Annexin V- and PI-positive.

Western Blotting for Protein Expression

Western blotting is used to detect specific proteins in a sample of tissue homogenate or extract.

Materials:

- Cancer cell lysates
- SDS-PAGE gels
- Transfer buffer
- PVDF or nitrocellulose membranes
- Blocking buffer (e.g., 5% non-fat milk or BSA in TBST)
- Primary antibodies (specific to target proteins)
- HRP-conjugated secondary antibodies
- Chemiluminescent substrate
- Imaging system

Procedure:

- Prepare protein lysates from cells treated with **Cudraflavone B** or Quercetin.
- Determine protein concentration using a BCA or Bradford assay.
- Separate the proteins by SDS-PAGE.
- Transfer the separated proteins to a PVDF or nitrocellulose membrane.
- Block the membrane with blocking buffer for 1 hour at room temperature.
- Incubate the membrane with the primary antibody overnight at 4°C.
- Wash the membrane three times with TBST.

- Incubate the membrane with the HRP-conjugated secondary antibody for 1 hour at room temperature.
- Wash the membrane three times with TBST.
- Add the chemiluminescent substrate and detect the signal using an imaging system.

Conclusion

Both **Cudraflavone B** and Quercetin demonstrate significant anticancer potential through the induction of apoptosis and cell cycle arrest, mediated by their influence on critical cellular signaling pathways. While Quercetin has been more extensively studied, **Cudraflavone B** shows promise as a potent anticancer agent, particularly in certain cancer types like glioblastoma. The provided data and protocols offer a valuable resource for researchers investigating these and other flavonoids for cancer therapy. Further head-to-head comparative studies are warranted to fully elucidate their relative therapeutic potential and to guide the selection of the most promising candidates for further preclinical and clinical development.

Need Custom Synthesis?

BenchChem offers custom synthesis for rare earth carbides and specific isotopic labeling.

Email: info@benchchem.com or [Request Quote Online](#).

References

- 1. Cudraflavone B induces human glioblastoma cells apoptosis via ER stress-induced autophagy - PMC [[pmc.ncbi.nlm.nih.gov](https://pubmed.ncbi.nlm.nih.gov/)]
- 2. [medchemexpress.com](https://www.medchemexpress.com/) [[medchemexpress.com](https://www.medchemexpress.com/)]
- 3. Quercetin Effects on Cell Cycle Arrest and Apoptosis and Doxorubicin Activity in T47D Cancer Stem Cells - PMC [[pmc.ncbi.nlm.nih.gov](https://pubmed.ncbi.nlm.nih.gov/)]
- 4. [researchgate.net](https://www.researchgate.net/) [[researchgate.net](https://www.researchgate.net/)]
- 5. [centaur.reading.ac.uk](https://www.centaur.reading.ac.uk/) [[centaur.reading.ac.uk](https://www.centaur.reading.ac.uk/)]
- 6. [mdpi.com](https://www.mdpi.com/) [[mdpi.com](https://www.mdpi.com/)]

- 7. Antiproliferative, Apoptotic Effects and Suppression of Oxidative Stress of Quercetin against Induced Toxicity in Lung Cancer Cells of Rats: In vitro and In vivo Study - PMC [pmc.ncbi.nlm.nih.gov]
- 8. khu.elsevierpure.com [khu.elsevierpure.com]
- 9. researchgate.net [researchgate.net]
- 10. researchgate.net [researchgate.net]
- 11. Anticancer and apoptosis-inducing effects of quercetin in vitro and in vivo - PMC [pmc.ncbi.nlm.nih.gov]
- 12. tandfonline.com [tandfonline.com]
- 13. Quercetin induces cell cycle arrest and apoptosis in CD133+ cancer stem cells of human colorectal HT29 cancer cell line and enhances anticancer effects of doxorubicin - PMC [pmc.ncbi.nlm.nih.gov]
- 14. Quercetin induces apoptosis and cell cycle arrest in triple-negative breast cancer cells through modulation of Foxo3a activity - PMC [pmc.ncbi.nlm.nih.gov]
- 15. researchgate.net [researchgate.net]
- 16. Quercetin Induces Cell Cycle Arrest and Apoptosis in YD10B and YD38 Oral Squamous Cell Carcinoma Cells - PubMed [pubmed.ncbi.nlm.nih.gov]
- 17. PI-103 and Quercetin Attenuate PI3K-AKT Signaling Pathway in T- Cell Lymphoma Exposed to Hydrogen Peroxide | PLOS One [journals.plos.org]
- 18. researchgate.net [researchgate.net]
- 19. aacrjournals.org [aacrjournals.org]
- 20. PI3K/Akt and ERK1/2 Signalling Are Involved in Quercetin-Mediated Neuroprotection against Copper-Induced Injury - PMC [pmc.ncbi.nlm.nih.gov]
- 21. researchgate.net [researchgate.net]
- To cite this document: BenchChem. [Cudraflavone B vs. Quercetin: A Comparative Guide to Anticancer Effects]. BenchChem, [2025]. [Online PDF]. Available at: [https://www.benchchem.com/product/b15609472#cudraflavone-b-vs-quercetin-a-comparison-of-anticancer-effects]

Disclaimer & Data Validity:

The information provided in this document is for Research Use Only (RUO) and is strictly not intended for diagnostic or therapeutic procedures. While BenchChem strives to provide

accurate protocols, we make no warranties, express or implied, regarding the fitness of this product for every specific experimental setup.

Technical Support: The protocols provided are for reference purposes. Unsure if this reagent suits your experiment? [[Contact our Ph.D. Support Team for a compatibility check](#)]

Need Industrial/Bulk Grade? [Request Custom Synthesis Quote](#)

BenchChem

Our mission is to be the trusted global source of essential and advanced chemicals, empowering scientists and researchers to drive progress in science and industry.

Contact

Address: 3281 E Guasti Rd

Ontario, CA 91761, United States

Phone: (601) 213-4426

Email: info@benchchem.com