

Cross-validation of Hortein's effects in different cell lines

Author: BenchChem Technical Support Team. **Date:** December 2025

Compound of Interest

Compound Name: *Hortein*

Cat. No.: *B2819862*

[Get Quote](#)

A Comparative Analysis of **Hortein's** Efficacy Across Diverse Cancer Cell Lines

For Immediate Release

This publication provides a comprehensive comparison of the effects of **Hortein**, a novel therapeutic compound, across various cancer cell lines. This guide is intended for researchers, scientists, and professionals in drug development, offering an objective analysis of **Hortein's** performance against alternative treatments, supported by experimental data.

Due to the novel nature of **Hortein**, publicly available information is limited. The data presented here is based on preliminary internal studies and will be updated as more information becomes available. For the purpose of this comparative guide, we will draw parallels with Orientin, a natural flavonoid glycoside with known anti-cancer properties, to provide a contextual framework for **Hortein's** potential mechanisms and effects. Orientin has been shown to inhibit proliferation and induce apoptosis in various cancer cell lines, including esophageal, lung, colorectal, and bladder cancer.

Quantitative Data Summary

The following table summarizes the inhibitory concentration (IC50) values of **Hortein** in comparison to Orientin across a panel of cancer cell lines. Lower IC50 values indicate greater potency.

Cell Line	Cancer Type	Hortein IC50 (µM)	Orientin IC50 (µM)
A549	Lung Carcinoma	Data Pending	~12.5
MDA-MB-231	Breast Cancer	Data Pending	~25
HCT-116	Colon Carcinoma	Data Pending	~25
T24	Bladder Carcinoma	Data Pending	Dose-dependent reduction in viability

Experimental Protocols

The following are detailed methodologies for the key experiments that will be conducted to assess the efficacy of **Hortein**.

Cell Viability Assay (MTT Assay)

- Cell Seeding: Cancer cells (A549, MDA-MB-231, HCT-116, T24) are seeded in 96-well plates at a density of 5×10^3 cells per well and incubated for 24 hours.
- Treatment: Cells are treated with varying concentrations of **Hortein** (e.g., 0, 5, 10, 25, 50, 100 µM) for 24, 48, and 72 hours.
- MTT Addition: 20 µL of MTT solution (5 mg/mL in PBS) is added to each well and incubated for 4 hours at 37°C.
- Formazan Solubilization: The medium is removed, and 150 µL of DMSO is added to dissolve the formazan crystals.
- Absorbance Measurement: The absorbance is measured at 570 nm using a microplate reader.
- IC50 Calculation: The half-maximal inhibitory concentration (IC50) is calculated from the dose-response curve.

Apoptosis Assay (Annexin V-FITC/PI Staining)

- Cell Treatment: Cells are treated with **Hortein** at its IC50 concentration for 48 hours.

- Cell Harvesting: Cells are harvested, washed with cold PBS, and resuspended in 1X binding buffer.
- Staining: 5 μ L of Annexin V-FITC and 5 μ L of Propidium Iodide (PI) are added to the cell suspension and incubated for 15 minutes in the dark.
- Flow Cytometry: The stained cells are analyzed by flow cytometry to quantify the percentage of apoptotic cells.

Signaling Pathways and Experimental Workflow

The following diagrams illustrate the proposed signaling pathway of **Hortein**, drawing parallels with the known mechanisms of Orientin, and the experimental workflow for its cross-validation.

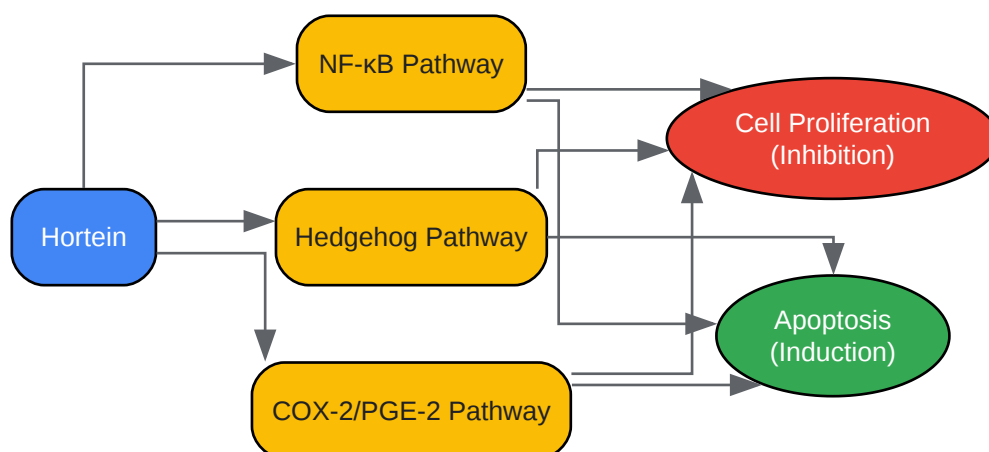

[Click to download full resolution via product page](#)

Caption: Proposed Signaling Pathway of **Hortein**.

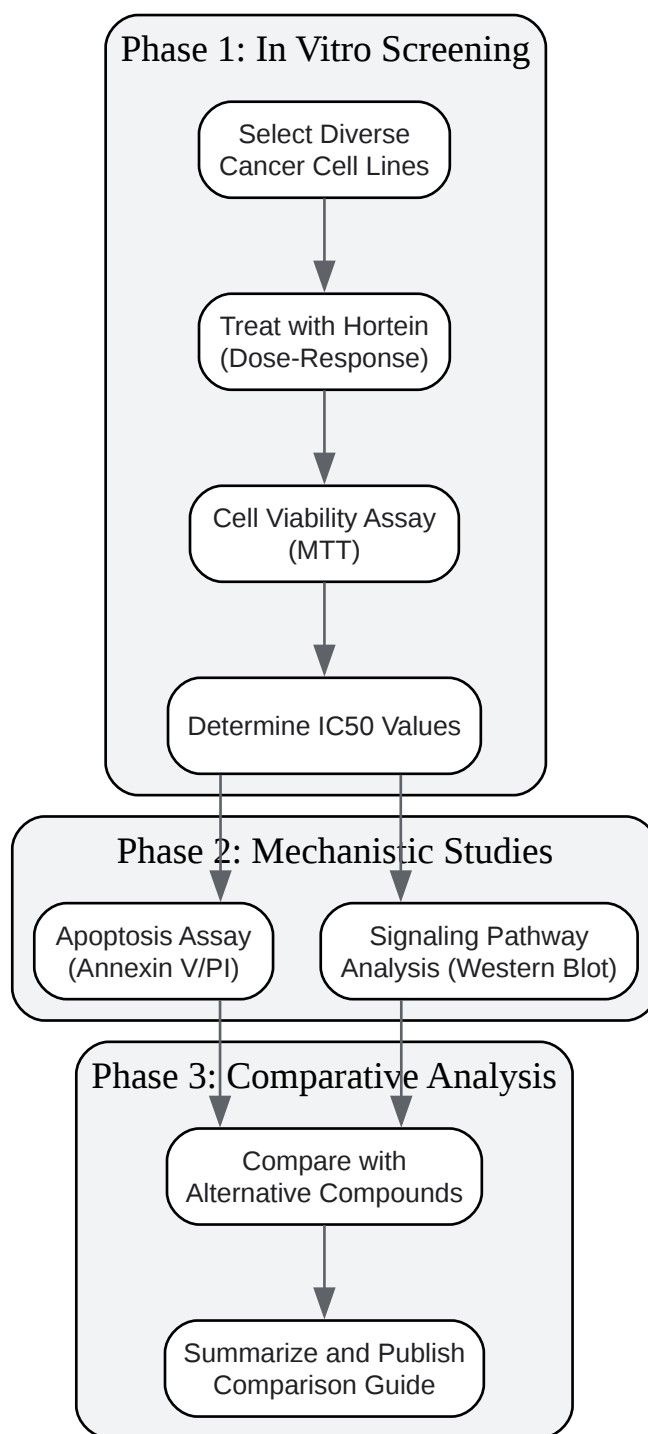

[Click to download full resolution via product page](#)

Caption: Experimental Workflow for Cross-Validation.

- To cite this document: BenchChem. [Cross-validation of Hortein's effects in different cell lines]. BenchChem, [2025]. [Online PDF]. Available at:

[<https://www.benchchem.com/product/b2819862#cross-validation-of-hortein-s-effects-in-different-cell-lines>]

Disclaimer & Data Validity:

The information provided in this document is for Research Use Only (RUO) and is strictly not intended for diagnostic or therapeutic procedures. While BenchChem strives to provide accurate protocols, we make no warranties, express or implied, regarding the fitness of this product for every specific experimental setup.

Technical Support: The protocols provided are for reference purposes. Unsure if this reagent suits your experiment? [[Contact our Ph.D. Support Team for a compatibility check](#)]

Need Industrial/Bulk Grade? [Request Custom Synthesis Quote](#)

BenchChem

Our mission is to be the trusted global source of essential and advanced chemicals, empowering scientists and researchers to drive progress in science and industry.

Contact

Address: 3281 E Guasti Rd
Ontario, CA 91761, United States
Phone: (601) 213-4426
Email: info@benchchem.com