

Comparison Guide: Cross-Reactivity Profile of Antidiabetic Agent 5

Author: BenchChem Technical Support Team. **Date:** December 2025

Compound of Interest

Compound Name: Antidiabetic agent 5

Cat. No.: B12371118

[Get Quote](#)

For Researchers, Scientists, and Drug Development Professionals

This guide provides a comparative analysis of the cross-reactivity profile of a hypothetical novel thiazolidinedione (TZD), "**Antidiabetic Agent 5**," against established drugs in its class, Rosiglitazone and Pioglitazone. The data presented herein is synthesized for illustrative purposes to guide researchers in evaluating the selectivity of new chemical entities.

Thiazolidinediones are potent insulin sensitizers that exert their effects by acting as agonists for the peroxisome proliferator-activated receptor-gamma (PPAR γ).^[1] Activation of PPAR γ regulates the transcription of genes involved in glucose and lipid metabolism.^[2] However, the clinical utility of TZDs has been hampered by adverse effects, including weight gain, fluid retention, and congestive heart failure, which can be linked to their cross-reactivity with other receptors or off-target effects.^{[3][4]} Therefore, a thorough assessment of the cross-reactivity profile of new TZD candidates is critical.

Data Presentation: Comparative Receptor Binding Affinity

The following table summarizes the binding affinities (K_i , nM) of "**Antidiabetic Agent 5**," Rosiglitazone, and Pioglitazone against a panel of selected nuclear receptors. Lower K_i values indicate higher binding affinity. Data for Agent 5 is hypothetical, assuming a higher selectivity for PPAR γ .

Target Receptor	Antidiabetic Agent 5 (Ki, nM)	Rosiglitazone (Ki, nM)	Pioglitazone (Ki, nM)
PPAR γ (Peroxisome Proliferator-Activated Receptor Gamma)	15	45	500
PPAR α (Peroxisome Proliferator-Activated Receptor Alpha)	5,000	>10,000	1,000
PPAR δ/β (Peroxisome Proliferator-Activated Receptor Delta/Beta)	>10,000	>10,000	>10,000
LXR (Liver X Receptor)	>10,000	>10,000	>10,000
FXR (Farnesoid X Receptor)	>10,000	>10,000	>10,000
GR (Glucocorticoid Receptor)	>10,000	>10,000	>10,000

Note: Data for Rosiglitazone and Pioglitazone are compiled from publicly available literature. Agent 5 data is hypothetical.

This data illustrates that while all three agents are potent PPAR γ agonists, Pioglitazone also shows some affinity for PPAR α .^[5] "Antidiabetic Agent 5" is designed to have a more selective profile for PPAR γ , which could potentially translate to a more favorable side-effect profile.

Experimental Protocols

Detailed methodologies are crucial for the accurate assessment of cross-reactivity. Below are protocols for key experiments used to generate the comparative data.

1. Radioligand Binding Assay

This assay is considered the gold standard for measuring the affinity of a ligand for a receptor. [6][7] It directly measures the binding of a radiolabeled ligand to a receptor preparation.

- Objective: To determine the binding affinity (K_i) of test compounds for various nuclear receptors.
- Materials:
 - Receptor-containing cell membrane preparations or purified receptor proteins.
 - Radioligand specific for the target receptor (e.g., [3H]-Rosiglitazone for PPAR γ).
 - Test compounds (**Antidiabetic Agent 5**, Rosiglitazone, Pioglitazone).
 - Assay buffer (e.g., 50 mM Tris, 5 mM MgCl₂, 0.1 mM EDTA, pH 7.4).[8]
 - 96-well filter plates.
 - Scintillation fluid.
 - Microplate scintillation counter.
- Procedure:
 - Prepare serial dilutions of the test compounds.
 - In a 96-well plate, add the receptor preparation, a fixed concentration of the radioligand, and varying concentrations of the test compound.[8]
 - Incubate the plate to allow the binding to reach equilibrium (e.g., 60 minutes at 30°C with gentle agitation).[8]
 - Separate the bound from the free radioligand by vacuum filtration through the filter plates. [6]
 - Wash the filters with ice-cold assay buffer to remove any unbound radioligand.
 - Dry the filters and add scintillation fluid.

- Measure the radioactivity in each well using a microplate scintillation counter.
- Data Analysis: The concentration of the test compound that inhibits 50% of the specific binding of the radioligand (IC50) is determined. The Ki is then calculated using the Cheng-Prusoff equation.

2. Cell-Based Transactivation Assay

This assay measures the functional consequence of ligand binding, specifically the activation of gene transcription by a nuclear receptor.

- Objective: To determine the functional potency (EC50) of test compounds as agonists for nuclear receptors.
- Materials:
 - Mammalian cell line (e.g., HEK293T).
 - Expression plasmid for the full-length nuclear receptor or a chimera of the receptor's ligand-binding domain and a GAL4 DNA-binding domain.[9]
 - Reporter plasmid containing a luciferase gene under the control of a promoter with response elements for the nuclear receptor (or GAL4).[10]
 - Transfection reagent.
 - Cell culture medium and supplements.
 - Test compounds.
 - Luciferase assay reagent.
 - Luminometer.
- Procedure:
 - Co-transfect the cells with the expression and reporter plasmids.[11]

- Plate the transfected cells in a 96-well plate and allow them to recover.
- Treat the cells with serial dilutions of the test compounds.
- Incubate for a sufficient period to allow for gene transcription and protein expression (e.g., 24 hours).
- Lyse the cells and add the luciferase assay reagent.
- Measure the luminescence in each well using a luminometer.
- Data Analysis: The concentration of the test compound that produces 50% of the maximal response (EC50) is determined by plotting the luminescence signal against the compound concentration.

Mandatory Visualization

The diagrams below illustrate the primary signaling pathway of TZDs and a typical workflow for assessing drug cross-reactivity.

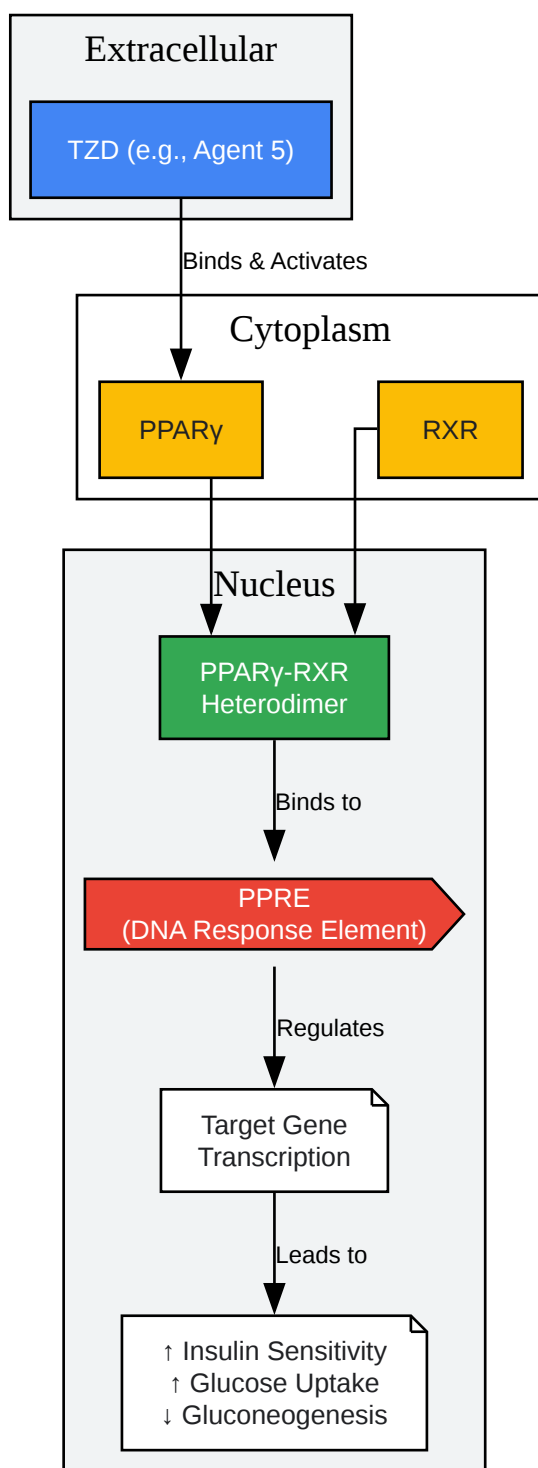

[Click to download full resolution via product page](#)

Caption: PPAR γ signaling pathway activated by Thiazolidinediones (TZDs).

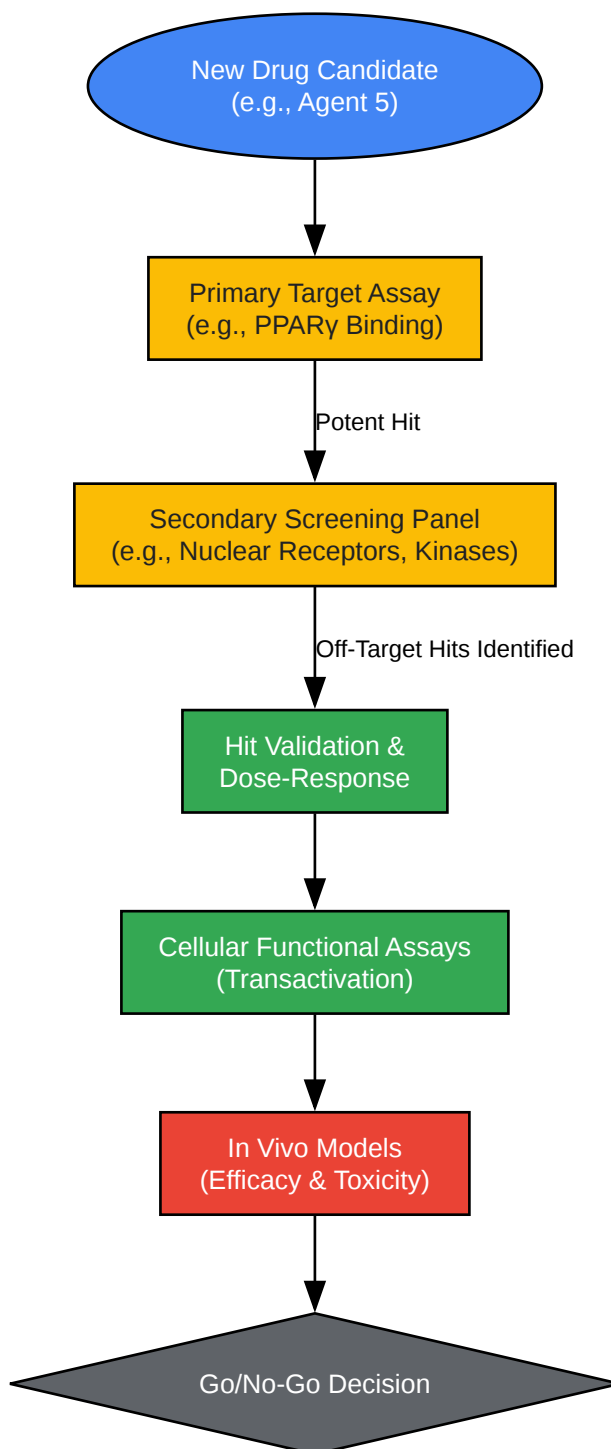

[Click to download full resolution via product page](#)

Caption: Workflow for assessing drug candidate cross-reactivity.

Need Custom Synthesis?

BenchChem offers custom synthesis for rare earth carbides and specific isotopic labeling.

Email: info@benchchem.com or [Request Quote Online](#).

References

- 1. Targeting Peroxisome Proliferator-Activated Receptors Using Thiazolidinediones: Strategy for Design of Novel Antidiabetic Drugs - PMC [pmc.ncbi.nlm.nih.gov]
- 2. go.drugbank.com [go.drugbank.com]
- 3. Thiazolidinediones and PPAR γ agonists: time for a reassessment - PubMed [pubmed.ncbi.nlm.nih.gov]
- 4. researchgate.net [researchgate.net]
- 5. Pioglitazone - StatPearls - NCBI Bookshelf [ncbi.nlm.nih.gov]
- 6. giffordbioscience.com [giffordbioscience.com]
- 7. Radioligand Binding Assay - Creative Bioarray [dda.creative-bioarray.com]
- 8. giffordbioscience.com [giffordbioscience.com]
- 9. researchgate.net [researchgate.net]
- 10. researchgate.net [researchgate.net]
- 11. A High-Throughput Mammalian Cell-Based Transient Transfection Assay | Springer Nature Experiments [experiments.springernature.com]
- To cite this document: BenchChem. [Comparison Guide: Cross-Reactivity Profile of Antidiabetic Agent 5]. BenchChem, [2025]. [Online PDF]. Available at: [https://www.benchchem.com/product/b12371118#antidiabetic-agent-5-cross-reactivity-studies]

Disclaimer & Data Validity:

The information provided in this document is for Research Use Only (RUO) and is strictly not intended for diagnostic or therapeutic procedures. While BenchChem strives to provide accurate protocols, we make no warranties, express or implied, regarding the fitness of this product for every specific experimental setup.

Technical Support: The protocols provided are for reference purposes. Unsure if this reagent suits your experiment? [[Contact our Ph.D. Support Team for a compatibility check](#)]

Need Industrial/Bulk Grade? [Request Custom Synthesis Quote](#)

BenchChem

Our mission is to be the trusted global source of essential and advanced chemicals, empowering scientists and researchers to drive progress in science and industry.

Contact

Address: 3281 E Guasti Rd

Ontario, CA 91761, United States

Phone: (601) 213-4426

Email: info@benchchem.com