

# Comparative recovery of Florfenicol amine using different extraction methods.

**Author:** BenchChem Technical Support Team. **Date:** December 2025

## Compound of Interest

Compound Name: Florfenicol amine (hydrochloride)

Cat. No.: B8802616

[Get Quote](#)

## A Head-to-Head Battle: Maximizing Florfenicol Amine Recovery in the Lab

A deep dive into the comparative efficacy of QuEChERS, Solid-Phase Extraction, and Liquid-Liquid Extraction for the recovery of Florfenicol amine, offering researchers critical data for informed methodological choices in residue analysis.

For researchers and professionals in drug development, the accurate quantification of antibiotic residues is paramount. Florfenicol, a broad-spectrum antibiotic used in veterinary medicine, and its primary metabolite, Florfenicol amine, are of particular interest due to regulatory limits in food products.<sup>[1]</sup> The choice of extraction method from complex biological matrices significantly influences analytical outcomes. This guide provides a comparative analysis of three prevalent extraction techniques—QuEChERS, Solid-Phase Extraction (SPE), and Liquid-Liquid Extraction (LLE)—to elucidate their performance in recovering Florfenicol amine.

## Performance Snapshot: Recovery Rates at a Glance

The efficiency of an extraction method is primarily judged by its recovery rate—the percentage of the target analyte successfully extracted from the sample matrix. The following table summarizes the comparative recovery of Florfenicol amine using QuEChERS, SPE, and LLE methods across various biological samples.

Extraction Method	Matrix	Florfenicol Amine Recovery (%)	Reference
QuEChERS	Eggs (Whole, Yolk, Albumen)	76.1 - 92.7	[2]
Tilapia Muscle	62 - 69	[3]	
Solid-Phase Extraction (SPE)	Bovine Muscle & Liver	93 - 104	[1]
Fish Muscle	89 - 106	[4]	
Catfish Muscle	85.7 - 92.3		
Cerebrospinal Fluid	91.7 - 98.8		
Liquid-Liquid Extraction (LLE)	Eggs (Whole, Yolk, Albumen)	71.6 - 90.2	

## In-Depth Experimental Protocols

To ensure reproducibility and methodological clarity, detailed protocols for each of the compared extraction techniques are provided below.

### QuEChERS (Quick, Easy, Cheap, Effective, Rugged, and Safe) Method

The QuEChERS method is a two-step process that involves an initial extraction with an organic solvent and partitioning salts, followed by a dispersive solid-phase extraction (d-SPE) cleanup.

#### 1. Sample Preparation:

- Homogenize 2-5 grams of the sample tissue.

#### 2. Extraction:

- Place the homogenized sample into a 50 mL centrifuge tube.
- Add 10 mL of acetonitrile (or acidified acetonitrile) and appropriate internal standards.

- Add a salt mixture, typically containing magnesium sulfate and sodium chloride, to induce liquid-liquid partitioning.
- Vortex the tube vigorously for 1 minute to ensure thorough mixing.
- Centrifuge at 4000-5000 rpm for 5 minutes.

### 3. Dispersive Solid-Phase Extraction (d-SPE) Cleanup:

- Transfer an aliquot of the upper acetonitrile layer to a d-SPE tube.
- The d-SPE tube contains a sorbent mixture, such as primary secondary amine (PSA) and C18, to remove interfering matrix components like fatty acids and pigments.
- Vortex for 30 seconds and then centrifuge.
- The resulting supernatant is the final extract, ready for analysis by LC-MS/MS.

## Solid-Phase Extraction (SPE)

SPE is a chromatographic technique used to extract, concentrate, and purify analytes from a complex mixture.

### 1. Sample Preparation and Hydrolysis:

- Weigh 2 grams of homogenized tissue into a 50 mL centrifuge tube.
- To convert Florfenicol and its metabolites to Florfenicol amine, add 5 mL of 6M hydrochloric acid.
- Incubate the sample at 90°C for 2 hours.
- Cool the sample to room temperature.
- Adjust the pH to  $\geq 12.5$  with 30% (w/v) sodium hydroxide.

### 2. SPE Cartridge Conditioning:

- Condition a reversed-phase SPE cartridge (e.g., Oasis MCX) by passing through methanol followed by water.

### 3. Sample Loading and Elution:

- Load the prepared sample onto the conditioned SPE cartridge.
- Wash the cartridge with a weak solvent to remove interferences.
- Elute the target analyte, Florfenicol amine, using an appropriate elution solvent.
- The eluate can then be concentrated and reconstituted in a suitable solvent for instrumental analysis.

## Liquid-Liquid Extraction (LLE)

LLE is a classic separation technique that partitions a solute between two immiscible liquid phases.

### 1. Sample Preparation:

- Homogenize the sample tissue.

### 2. Extraction:

- Add the homogenized sample to a separation funnel.
- Add an immiscible organic solvent (e.g., ethyl acetate).
- Shake the funnel vigorously to facilitate the transfer of Florfenicol amine from the aqueous sample matrix to the organic solvent.
- Allow the two phases to separate.

### 3. Collection and Concentration:

- Collect the organic layer containing the extracted Florfenicol amine.

- The solvent is then typically evaporated, and the residue is reconstituted in a smaller volume of a suitable solvent for analysis.

## Visualizing the Workflow

To better illustrate the logical flow of comparing these extraction methods, the following diagram outlines the experimental process.

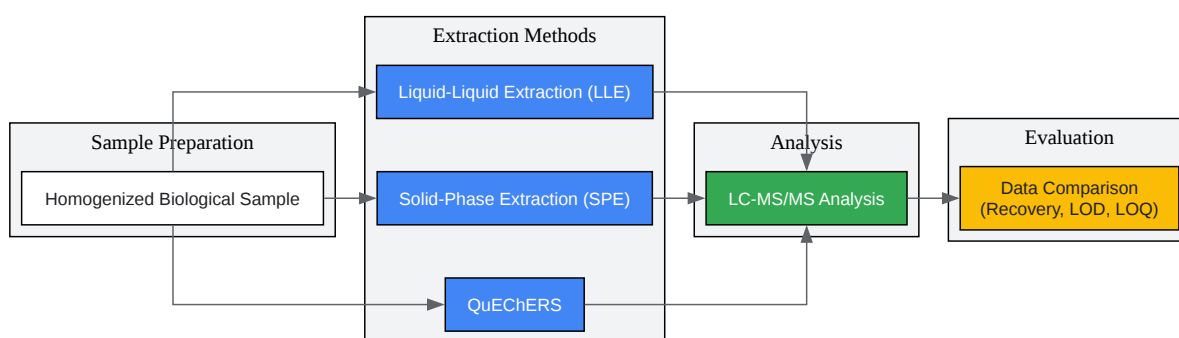

[Click to download full resolution via product page](#)

Caption: Comparative workflow for Florfenicol amine extraction methods.

## Conclusion

The selection of an appropriate extraction method is a critical decision in the analytical workflow for Florfenicol amine. While SPE often demonstrates higher recovery rates, particularly in complex matrices like bovine tissues, the QuEChERS method offers a simpler and more rapid alternative, proving effective for samples such as eggs. LLE remains a fundamental technique, though it may yield slightly lower recovery compared to the other methods. Ultimately, the optimal choice depends on the specific research needs, including the matrix type, required sensitivity, and available resources. The data and protocols presented here serve as a valuable resource for making an informed decision to ensure accurate and reliable quantification of Florfenicol amine residues.

**Need Custom Synthesis?**

BenchChem offers custom synthesis for rare earth carbides and specific isotopic labeling.

Email: [info@benchchem.com](mailto:info@benchchem.com) or [Request Quote Online](#).

## References

- 1. benchchem.com [benchchem.com]
- 2. Development of a QuEChERS–HPLC–FLD Procedure for the Simultaneous Detection of Residues of Florfenicol, Its Metabolite Florfenicol Amine, and Three Fluoroquinolones in Eggs - PMC [pmc.ncbi.nlm.nih.gov]
- 3. researchgate.net [researchgate.net]
- 4. Phenylboronic Acid Solid Phase Extraction Cleanup and Isotope Dilution Liquid Chromatography-Tandem Mass Spectrometry for the Determination of Florfenicol Amine in Fish Muscles - PubMed [pubmed.ncbi.nlm.nih.gov]
- To cite this document: BenchChem. [Comparative recovery of Florfenicol amine using different extraction methods.]. BenchChem, [2025]. [Online PDF]. Available at: [https://www.benchchem.com/product/b8802616#comparative-recovery-of-florfenicol-amine-using-different-extraction-methods]

---

### Disclaimer & Data Validity:

The information provided in this document is for Research Use Only (RUO) and is strictly not intended for diagnostic or therapeutic procedures. While BenchChem strives to provide accurate protocols, we make no warranties, express or implied, regarding the fitness of this product for every specific experimental setup.

**Technical Support:** The protocols provided are for reference purposes. Unsure if this reagent suits your experiment? [[Contact our Ph.D. Support Team for a compatibility check](#)]

**Need Industrial/Bulk Grade?** [Request Custom Synthesis Quote](#)

# BenchChem

Our mission is to be the trusted global source of essential and advanced chemicals, empowering scientists and researchers to drive progress in science and industry.

## Contact

Address: 3281 E Guasti Rd

Ontario, CA 91761, United States

Phone: (601) 213-4426

Email: [info@benchchem.com](mailto:info@benchchem.com)