

Comparative Transcriptomic Analysis of Umckalin and Alternative Immunomodulators in Cellular Models

Author: BenchChem Technical Support Team. **Date:** December 2025

Compound of Interest

Compound Name: *Umckalin*

Cat. No.: *B150616*

[Get Quote](#)

A Guide for Researchers and Drug Development Professionals

In the quest for effective immunomodulatory agents for respiratory and inflammatory conditions, understanding the molecular mechanisms at the transcriptomic level is paramount. This guide provides a comparative analysis of the transcriptomic effects of **Umckalin**, the key bioactive compound in *Pelargonium sidoides*, with other well-known herbal immunomodulators: *Echinacea*, *Sambucus nigra* (elderberry), and *Andrographis paniculata*. Due to the absence of publicly available comprehensive transcriptomic datasets for **Umckalin**-treated cells, this comparison is based on documented effects on specific gene and protein expression, juxtaposed with available transcriptomic data for the alternative compounds.

Data Summary: Gene Expression Modulation

The following tables summarize the known effects of **Umckalin** (*Pelargonium sidoides*) and the comparative transcriptomic data from studies on *Echinacea*, *Sambucus nigra*, and *Andrographis paniculata* on key immune and inflammatory genes.

Table 1: Comparative Effects on Pro-Inflammatory Gene Expression

Gene/Protein	Umckalin / Pelargonium sidoides Extract	Echinacea purpurea Extract	Sambucus nigra (Elderberry) Extract	Andrographis paniculata (Andrographolide)
TNF- α	Inhibition of expression and production[1]	Initial induction, then modest decrease in vivo[2]	Increased expression[3]	Inhibition of expression[4][5]
IL-6	Inhibition of production[1]	-	Increased expression[3]	Inhibition of expression[4][5]
IL-1 β	Inhibition of production[1]	Initial induction, then modest decrease in vivo[2]	-	Inhibition of expression[4]
iNOS	Inhibition of expression[1]	-	-	Inhibition of production[6]
COX-2	Inhibition of expression[1]	-	-	Inhibition of expression[4]
IL-8	-	Initial induction, then modest decrease in vivo[2]	Increased expression[3]	Downregulation of expression[5]
CCL2 (MCP-1)	-	Upregulation in dendritic cells[7]	-	Downregulation of expression[5]
CCL3 (MIP-1 α)	-	Downregulation in dendritic cells[7]	-	-
CCL4 (MIP-1 β)	-	Upregulation in dendritic cells[7]	-	-

Table 2: Comparative Effects on Immune Response and Antiviral Gene Expression

Gene/Protein	Umckalin / Pelargonium sidoides Extract	Echinacea purpurea Extract	Sambucus nigra (Elderberry) Extract	Andrographis paniculata (Andrographol ide)
IFN- α	-	Steady increase in vivo[2]	-	-
IFN- β	Induction of production	-	-	-
SOCS-1	Upregulation	-	-	-
β -defensin-1	Upregulation	-	-	-
ICOS	Decreased expression	-	-	-
ICOSL	Decreased expression	-	-	-
IL-10	Induction of production	Initial induction in vitro[2]	-	Decreased production[5]
MHC Class II	-	Stimulation of expression[8]	-	-

Experimental Protocols

Detailed methodologies are crucial for the interpretation and replication of transcriptomic studies. Below are representative experimental protocols from the cited literature for the alternative immunomodulators.

Echinacea purpurea Extract Treatment of Human Bronchial Epithelial Cells

- Cell Line: BEAS-2B (human bronchial epithelial cell line).
- Treatment: Cells were treated with either a polysaccharide-rich or an alkylamide and caffeic acid derivative-rich extract of Echinacea purpurea.

- Infection Model: In some experiments, cells were infected with human rhinovirus (HRV-14) prior to or concurrently with Echinacea treatment.
- RNA Extraction and Analysis: Total RNA was extracted, and gene expression was analyzed using the Affymetrix Human Genome U133A 2.0 Array, evaluating over 13,000 human genes.
- Data Analysis: Gene expression changes were analyzed to identify differentially expressed genes, which were then subjected to pathway analysis using programs like Ingenuity Pathway Analysis to identify key regulatory nodes.[8]

Sambucus nigra (Elderberry) Extract Treatment in an Influenza Model

- Methodology: The study aimed to determine the mechanism of action of elderberry against influenza virus.
- Assays: Direct effects were studied via hemagglutination inhibition, plaque reduction, and flow cytometry.
- Cytokine Analysis: To assess immunomodulatory effects, the modulation of pro-inflammatory cytokines (IL-6, IL-8, and TNF- α) was evaluated. The study found an increased expression of these cytokines, suggesting an indirect immunomodulatory effect.[3]

Andrographis paniculata (Andrographolide) in a Co-culture Inflammation Model

- Cell Lines: Caco-2 (human epithelial colorectal adenocarcinoma) and RAW264.7 (murine macrophage) cells were co-cultured.
- Treatment: The co-culture was treated with an ethanolic extract of Andrographis paniculata (ApEtOH).
- Inflammation Induction: Inflammation was induced by lipopolysaccharide (LPS).
- Gene Expression Analysis: The expression of chemokines (RANTES, MCP-1, and ENA-78) in Caco-2 cells infected with Salmonella Typhimurium was assessed via quantitative real-time PCR (qRT-PCR).
- Cytokine Measurement: Production of TNF- α and IL-6 was measured by ELISA.[5]

Visualizing Molecular Pathways and Workflows

The following diagrams, generated using Graphviz, illustrate the known signaling pathways affected by **Umckalin** and a general workflow for transcriptomic analysis of herbal extracts.

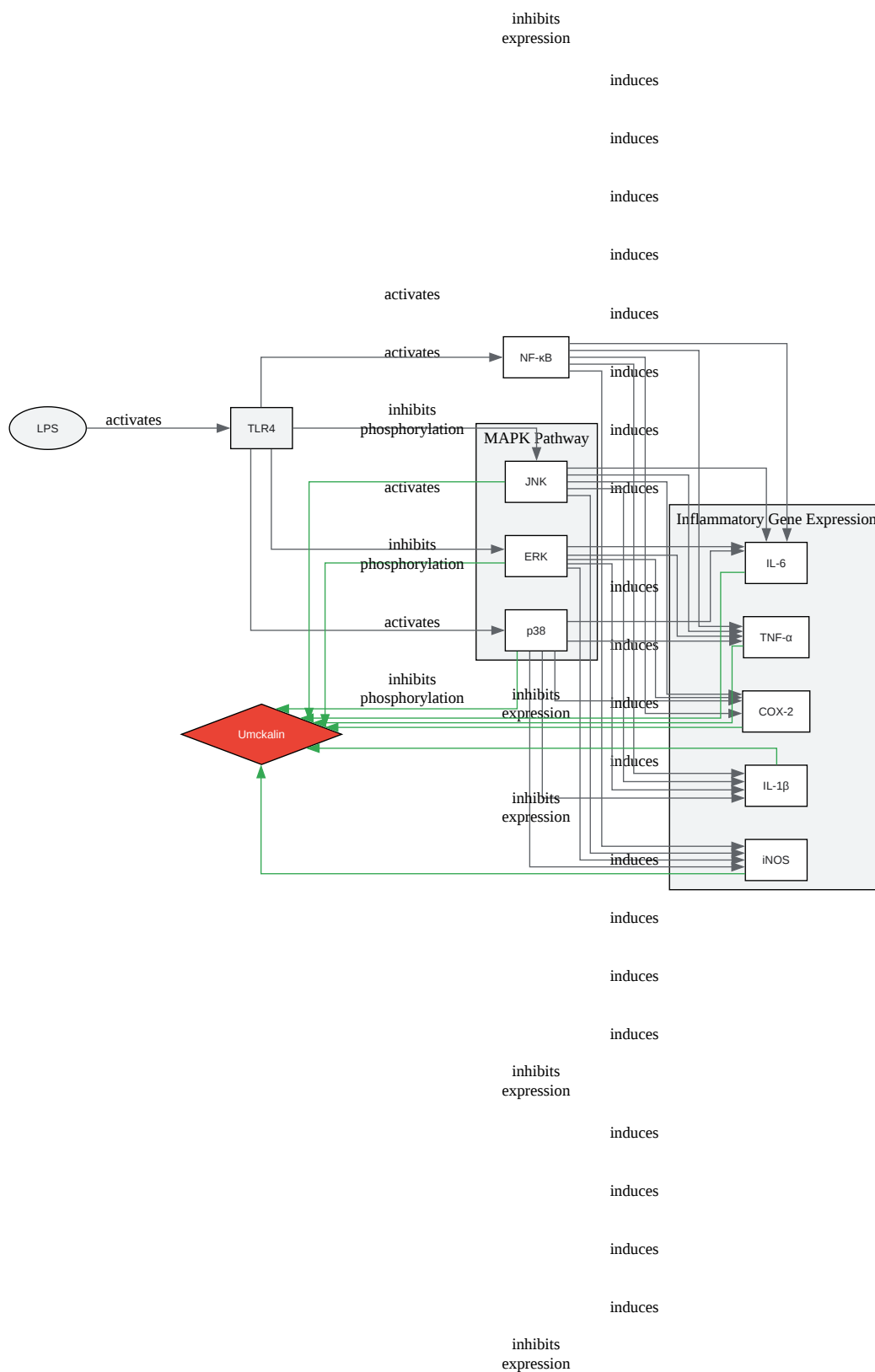

[Click to download full resolution via product page](#)

Caption: **Umckalin's** anti-inflammatory signaling pathway.

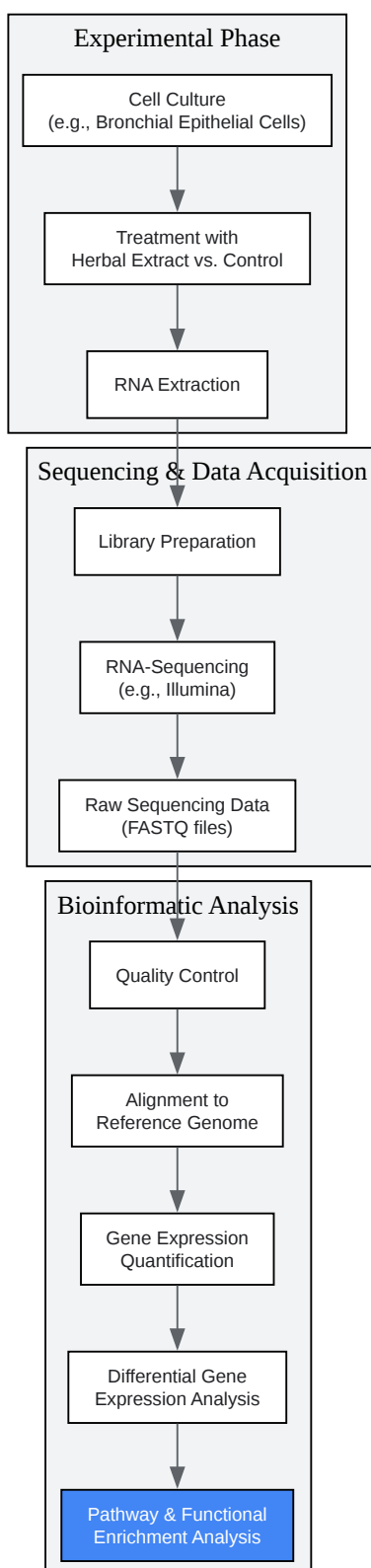

[Click to download full resolution via product page](#)

Caption: General workflow for transcriptomic analysis.

Conclusion

While a direct, high-throughput transcriptomic comparison involving **Umckalin** is not yet available in the public domain, the existing evidence on its molecular targets provides a solid foundation for a comparative assessment. **Umckalin**, and the broader Pelargonium sidoides extract, demonstrates a potent anti-inflammatory profile by downregulating key pro-inflammatory mediators such as TNF- α , IL-6, iNOS, and COX-2, primarily through the inhibition of the MAPK signaling pathway.[1] In comparison, herbal immunomodulators like Echinacea and Sambucus nigra show a more complex, and sometimes contrasting, immunomodulatory effect, with some studies indicating an initial induction of pro-inflammatory cytokines.[2][3][8] Andrographis paniculata appears to share a more similar anti-inflammatory transcriptomic signature with **Umckalin**, notably in its inhibition of the NF- κ B and MAPK pathways.[4][6]

For researchers and drug development professionals, this guide highlights the necessity for comprehensive transcriptomic studies on **Umckalin** to fully elucidate its mechanism of action and to enable more direct and quantitative comparisons with alternative therapies. The inferred comparative data presented here, however, underscores the distinct molecular impact of these herbal compounds on the immune system and provides a valuable framework for future research and development in the field of immunomodulation.

Need Custom Synthesis?

BenchChem offers custom synthesis for rare earth carbides and specific isotopic labeling.

Email: info@benchchem.com or [Request Quote Online](#).

References

- 1. ijpsr.com [ijpsr.com]
- 2. Regulation of human immune gene expression as influenced by a commercial blended Echinacea product: preliminary studies - PubMed [pubmed.ncbi.nlm.nih.gov]
- 3. cabidigitallibrary.org [cabidigitallibrary.org]
- 4. Biological properties of andrographolide, an active ingredient of Andrographis Paniculata: a narrative review - PMC [pmc.ncbi.nlm.nih.gov]

- 5. [Frontiers | Andrographis paniculata restores gut health by suppressing inflammation and strengthening mucosal immunity \[frontiersin.org\]](#)
- 6. [researchgate.net \[researchgate.net\]](#)
- 7. [Modulatory effects of Echinacea purpurea extracts on human dendritic cells: a cell- and gene-based study - PubMed \[pubmed.ncbi.nlm.nih.gov\]](#)
- 8. [Modulation of immune response gene expression by echinacea extracts: results of a gene array analysis - PubMed \[pubmed.ncbi.nlm.nih.gov\]](#)
- To cite this document: BenchChem. [Comparative Transcriptomic Analysis of Umckalin and Alternative Immunomodulators in Cellular Models]. BenchChem, [2025]. [Online PDF]. Available at: [<https://www.benchchem.com/product/b150616#comparative-transcriptomics-of-umckalin-treated-cells>]

Disclaimer & Data Validity:

The information provided in this document is for Research Use Only (RUO) and is strictly not intended for diagnostic or therapeutic procedures. While BenchChem strives to provide accurate protocols, we make no warranties, express or implied, regarding the fitness of this product for every specific experimental setup.

Technical Support: The protocols provided are for reference purposes. Unsure if this reagent suits your experiment? [[Contact our Ph.D. Support Team for a compatibility check](#)]

Need Industrial/Bulk Grade? [Request Custom Synthesis Quote](#)

BenchChem

Our mission is to be the trusted global source of essential and advanced chemicals, empowering scientists and researchers to drive progress in science and industry.

Contact

Address: 3281 E Guasti Rd
Ontario, CA 91761, United States
Phone: (601) 213-4426
Email: info@benchchem.com