

# Comparative Receptor Binding Analysis: Analgesic agent-1

**Author:** BenchChem Technical Support Team. **Date:** December 2025

## Compound of Interest

Compound Name: Analgesic agent-1

Cat. No.: B15141981

[Get Quote](#)

This guide provides a comparative analysis of "**Analgesic agent-1**," a novel compound, against the benchmark opioid analgesic, morphine. The data presented herein is intended for researchers, scientists, and professionals in the field of drug development to objectively evaluate the receptor binding characteristics of this new agent.

## Receptor Binding Affinity

The binding affinity of **Analgesic agent-1** and morphine was determined at three primary opioid receptor subtypes: mu ( $\mu$ ), delta ( $\delta$ ), and kappa ( $\kappa$ ). The inhibition constant ( $K_i$ ), a measure of binding affinity, was quantified for each compound at human recombinant receptors expressed in Chinese hamster ovary (CHO) cell membranes. A lower  $K_i$  value indicates a higher binding affinity.

The results, summarized in the table below, indicate that **Analgesic agent-1** exhibits significantly higher affinity and selectivity for the mu-opioid receptor compared to morphine.

Compound	Mu ( $\mu$ ) Receptor $K_i$ (nM)	Delta ( $\delta$ ) Receptor $K_i$ (nM)	Kappa ( $\kappa$ ) Receptor $K_i$ (nM)	$\mu/\delta$ Selectivity Ratio	$\mu/\kappa$ Selectivity Ratio
Analgesic agent-1	0.15	120	250	800	1667
Morphine	1.2[1]	210	350	175	292

Table 1: Comparative receptor binding affinities ( $K_i$ , nM) of **Analgesic agent-1** and Morphine at human opioid receptors. Selectivity ratios were calculated as  $K_i$  ( $\delta$  or  $\kappa$ ) /  $K_i$  ( $\mu$ ).

## Experimental Protocols

### Competitive Radioligand Binding Assay

The binding affinities of the test compounds were determined using a competitive radioligand binding assay.[2][3] This method measures the ability of a test compound to displace a known high-affinity radioligand from its receptor.

- Receptor Source: Commercially available cell membranes from CHO cell lines stably expressing either the human mu ( $\mu$ ), delta ( $\delta$ ), or kappa ( $\kappa$ ) opioid receptor were used.[3]
- Radioligands:
  - Mu ( $\mu$ ) Receptor: [ $^3$ H]-DAMGO, a selective mu-opioid peptide agonist, was used.[3]
  - Delta ( $\delta$ ) Receptor: [ $^3$ H]-DPDPE, a selective delta-opioid peptide agonist, was used.
  - Kappa ( $\kappa$ ) Receptor: [ $^3$ H]-U69,593, a selective kappa-opioid agonist, was used.
- Assay Buffer: 50 mM Tris-HCl, 3 mM MgCl<sub>2</sub>, 0.2 mM EGTA, pH 7.7.
- Procedure:
  - Cell membranes (10-20  $\mu$ g of protein) were incubated with a fixed concentration of the respective radioligand and varying concentrations of the competitive test compound (**Analgesic agent-1** or morphine).
  - Non-specific binding was determined in the presence of a high concentration (10  $\mu$ M) of a non-radiolabeled, high-affinity ligand such as Naloxone.
  - Incubation was carried out for 60 minutes at room temperature in 96-well plates.
  - The reaction was terminated by rapid filtration through glass fiber filters using a cell harvester, separating the receptor-bound radioligand from the unbound radioligand.

- The filters were washed with ice-cold wash buffer (50 mM Tris-HCl, pH 7.4).
- Radioactivity trapped on the filters was quantified using a liquid scintillation counter.
- Data Analysis: The concentration of the test compound that inhibits 50% of the specific binding of the radioligand (IC<sub>50</sub>) was determined from competition curves. The inhibition constant (K<sub>i</sub>) was then calculated using the Cheng-Prusoff equation:  $K_i = IC_{50} / (1 + [L]/K_d)$ , where [L] is the concentration of the radioligand and K<sub>d</sub> is its dissociation constant.

## Visualizations

The following diagrams illustrate the experimental workflow for the receptor binding assay and the canonical signaling pathway of the mu-opioid receptor.

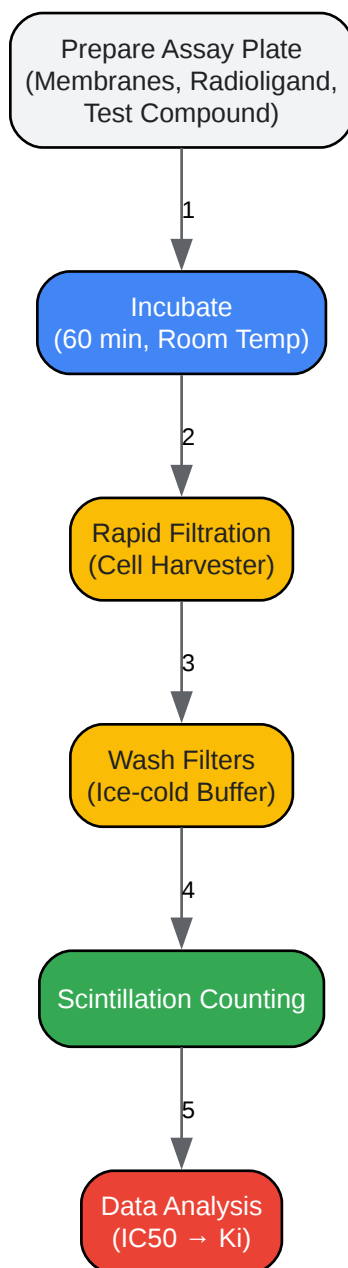

[Click to download full resolution via product page](#)

## Radioligand Binding Assay Workflow

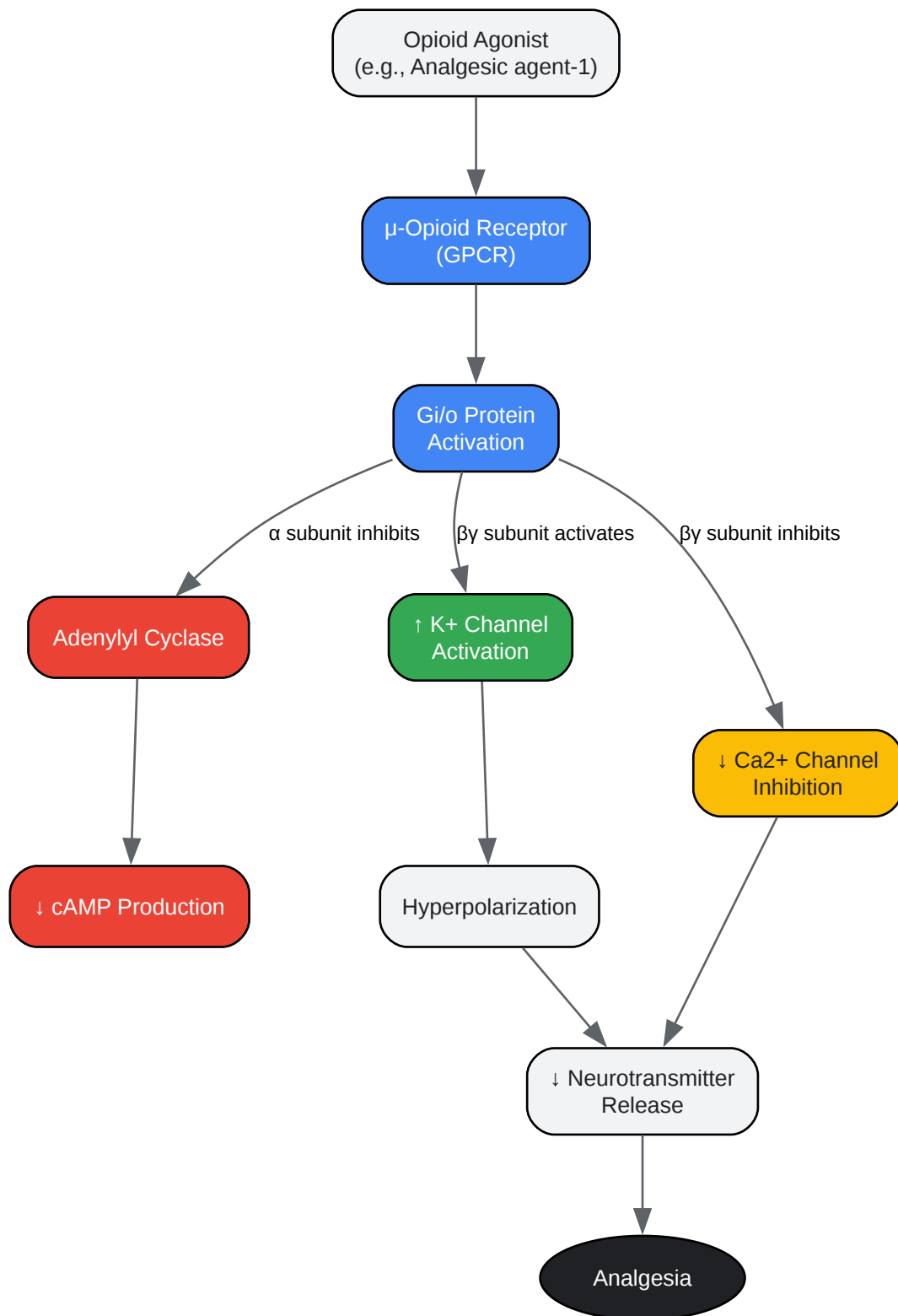

[Click to download full resolution via product page](#)

Mu-Opioid Receptor Signaling Pathway

The primary signaling pathway for the mu-opioid receptor involves coupling to inhibitory G-proteins (Gi/o). Activation of the receptor by an agonist leads to the inhibition of adenylyl cyclase, which reduces intracellular cAMP levels. Additionally, the G-protein subunits can directly activate inwardly rectifying potassium channels and inhibit voltage-gated calcium channels. These actions collectively lead to neuronal hyperpolarization and a reduction in neurotransmitter release, producing the analgesic effect.

#### Need Custom Synthesis?

BenchChem offers custom synthesis for rare earth carbides and specific isotopic labeling.

Email: [info@benchchem.com](mailto:info@benchchem.com) or [Request Quote Online](#).

## References

- 1. Mu receptor binding of some commonly used opioids and their metabolites - PubMed [[pubmed.ncbi.nlm.nih.gov](https://pubmed.ncbi.nlm.nih.gov)]
- 2. benchchem.com [[benchchem.com](https://www.benchchem.com)]
- 3. Receptor-Binding Assay. [[bio-protocol.org](https://www.bio-protocol.org)]
- To cite this document: BenchChem. [Comparative Receptor Binding Analysis: Analgesic agent-1]. BenchChem, [2025]. [Online PDF]. Available at: [<https://www.benchchem.com/product/b15141981#analgesic-agent-1-comparative-receptor-binding-studies>]

---

#### Disclaimer & Data Validity:

The information provided in this document is for Research Use Only (RUO) and is strictly not intended for diagnostic or therapeutic procedures. While BenchChem strives to provide accurate protocols, we make no warranties, express or implied, regarding the fitness of this product for every specific experimental setup.

**Technical Support:** The protocols provided are for reference purposes. Unsure if this reagent suits your experiment? [[Contact our Ph.D. Support Team for a compatibility check](#)]

**Need Industrial/Bulk Grade?** [Request Custom Synthesis Quote](#)

# BenchChem

Our mission is to be the trusted global source of essential and advanced chemicals, empowering scientists and researchers to drive progress in science and industry.

## Contact

Address: 3281 E Guasti Rd

Ontario, CA 91761, United States

Phone: (601) 213-4426

Email: [info@benchchem.com](mailto:info@benchchem.com)