

# Comparative In Vivo Potency of BMS-587101: A Guide for Researchers

**Author:** BenchChem Technical Support Team. **Date:** December 2025

## Compound of Interest

Compound Name: BMS-587101

Cat. No.: B1667226

[Get Quote](#)

This guide provides a detailed comparison of the in vivo potency of **BMS-587101**, a small-molecule antagonist of Leukocyte Function-Associated Antigen-1 (LFA-1), against other relevant anti-inflammatory compounds. The data presented is intended for researchers, scientists, and drug development professionals working on novel therapeutics for autoimmune and inflammatory diseases.

**BMS-587101** inhibits the interaction between LFA-1 and Intercellular Adhesion Molecule (ICAM), a critical step in the inflammatory cascade involving T-cell activation, adhesion, and migration.[1] This guide focuses on its efficacy in established preclinical models of arthritis and compares its performance with other therapeutic agents, including a monoclonal antibody targeting LFA-1.

## Mechanism of Action: LFA-1 Signaling Pathway

**BMS-587101** exerts its anti-inflammatory effects by targeting the LFA-1/ICAM-1 interaction. This interaction is crucial for the adhesion of T-cells to endothelial cells, a prerequisite for their migration into inflamed tissues. By blocking this, **BMS-587101** effectively inhibits T-cell proliferation and the production of pro-inflammatory Th1 cytokines.[2][3]

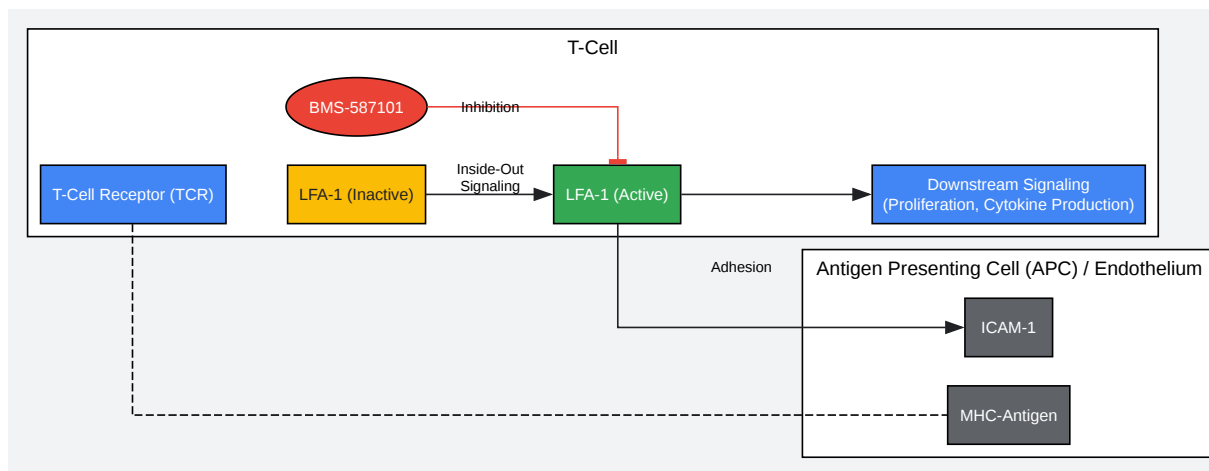

[Click to download full resolution via product page](#)

Caption: LFA-1 signaling and inhibition by **BMS-587101**.

## In Vivo Potency in Murine Arthritis Models

**BMS-587101** has demonstrated significant efficacy in reducing disease severity in both antibody-induced arthritis (AIA) and collagen-induced arthritis (CIA) mouse models. Its potency was found to be comparable or superior to that of an anti-mouse LFA-1 monoclonal antibody (M17).<sup>[2][3]</sup>

### Antibody-Induced Arthritis (AIA) Model

In the AIA model, which mimics the inflammatory phase of arthritis, **BMS-587101** was administered therapeutically after the onset of clinical symptoms.

Compound	Dose	Route	Efficacy Metric	Result	Reference
BMS-587101	65 mg/kg	Oral (BID)	Reduction in Clinical Score	Significant reduction vs. vehicle	[3]
BMS-587101	100 mg/kg	Oral (BID)	Reduction in Clinical Score	Significant reduction, comparable to M17	[3]
Anti-LFA-1 mAb (M17)	100 µg	S.C. (once)	Reduction in Clinical Score	Significant reduction vs. vehicle	[3]
Vehicle	N/A	Oral (BID)	Clinical Score	Progressive increase in arthritis severity	[3]

## Collagen-Induced Arthritis (CIA) Model

In the more complex CIA model, which involves autoimmune T-cell and B-cell responses, **BMS-587101** treatment resulted in marked protection from inflammation and bone destruction.[2]

Compound	Dose	Route	Efficacy Metric	Result	Reference
BMS-587101	Not Specified	Oral	Joint Inflammation & Destruction	Marked protection	[2]
Vehicle	N/A	Oral	Joint Inflammation & Destruction	Extensive inflammation and bone destruction	[2]

## Cytokine Modulation

**BMS-587101** treatment also led to a significant reduction in the mRNA levels of pro-inflammatory cytokines in the joints of arthritic animals compared to vehicle-treated controls.[2]

## Experimental Protocols

The following section details the methodology for the antibody-induced arthritis model, a key experiment for evaluating the in vivo potency of anti-inflammatory compounds like **BMS-587101**.

### Antibody-Induced Arthritis (AIA) Experimental Workflow

- **Disease Induction:** Arthritis is induced in BALB/c mice via an intravenous injection of a cocktail of anti-collagen type II monoclonal antibodies.
- **Lipopolysaccharide (LPS) Challenge:** Three days after the antibody injection, mice receive an intraperitoneal injection of LPS to synchronize and enhance the inflammatory response.
- **Disease Onset & Scoring:** Clinical signs of arthritis (erythema, paw swelling) typically appear within 24-48 hours after the LPS challenge. Disease severity is monitored daily using a clinical scoring system.
- **Therapeutic Intervention:** Once the average clinical score reaches a predetermined threshold (e.g.,  $\geq 2$ ), mice are randomized into treatment groups.
- **Compound Administration:** **BMS-587101** or vehicle is administered orally, typically twice a day (BID). Comparator compounds, such as monoclonal antibodies, are administered as a single subcutaneous injection.
- **Endpoint Analysis:** The primary endpoint is the daily clinical score. Secondary endpoints can include paw swelling measurements, histological analysis of joints for inflammation and bone erosion, and measurement of cytokine levels in joint tissue.

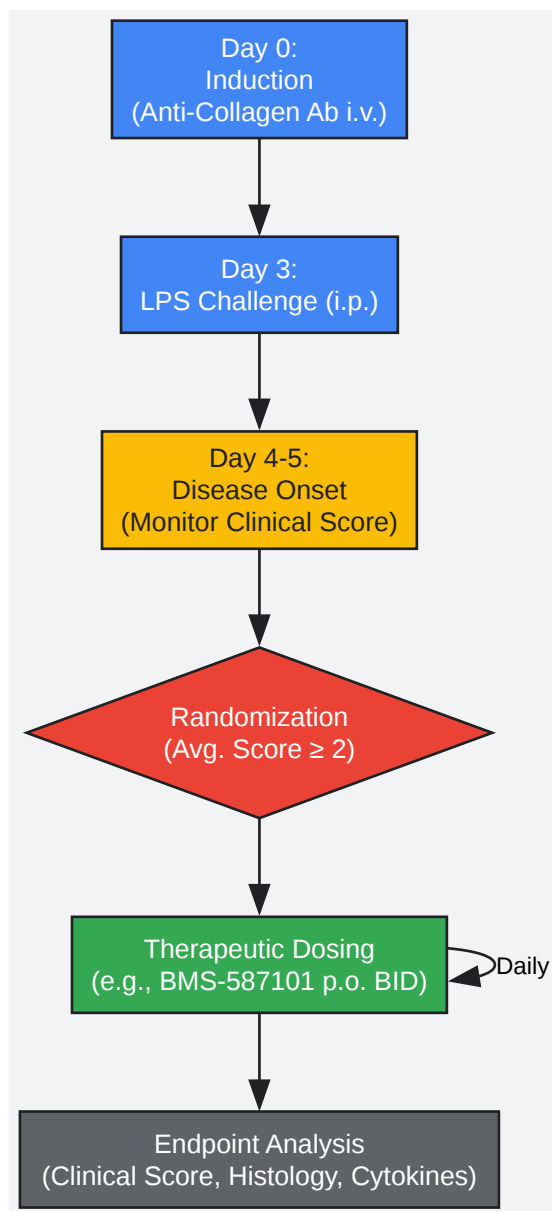

[Click to download full resolution via product page](#)

Caption: Workflow for the Antibody-Induced Arthritis (AIA) model.

## Conclusion

The available in vivo data robustly supports the potency of **BMS-587101** as an LFA-1 antagonist for the treatment of inflammatory diseases. In preclinical models of arthritis, it demonstrates efficacy that is comparable, and in some aspects superior, to antibody-based therapies targeting the same pathway.[2] Its oral bioavailability presents a significant advantage over parenteral administration of biologicals.[2] The data indicates that **BMS-587101** effectively

reduces clinical signs of arthritis, protects against joint destruction, and modulates the underlying pro-inflammatory cytokine environment. These findings underscore the therapeutic potential of small-molecule LFA-1 antagonists in diseases like rheumatoid arthritis.[2]

#### Need Custom Synthesis?

BenchChem offers custom synthesis for rare earth carbides and specific isotopic labeling.

Email: [info@benchchem.com](mailto:info@benchchem.com) or [Request Quote Online](#).

## References

- 1. [newdrugapprovals.org](http://newdrugapprovals.org) [[newdrugapprovals.org](http://newdrugapprovals.org)]
- 2. An LFA-1 (alphaLbeta2) small-molecule antagonist reduces inflammation and joint destruction in murine models of arthritis - PubMed [[pubmed.ncbi.nlm.nih.gov](http://pubmed.ncbi.nlm.nih.gov)]
- 3. [researchgate.net](http://researchgate.net) [[researchgate.net](http://researchgate.net)]
- To cite this document: BenchChem. [Comparative In Vivo Potency of BMS-587101: A Guide for Researchers]. BenchChem, [2025]. [Online PDF]. Available at: [<https://www.benchchem.com/product/b1667226#in-vivo-potency-of-bms-587101-compared-to-other-compounds>]

---

#### Disclaimer & Data Validity:

The information provided in this document is for Research Use Only (RUO) and is strictly not intended for diagnostic or therapeutic procedures. While BenchChem strives to provide accurate protocols, we make no warranties, express or implied, regarding the fitness of this product for every specific experimental setup.

**Technical Support:** The protocols provided are for reference purposes. Unsure if this reagent suits your experiment? [[Contact our Ph.D. Support Team for a compatibility check](#)]

**Need Industrial/Bulk Grade?** [Request Custom Synthesis Quote](#)

# BenchChem

Our mission is to be the trusted global source of essential and advanced chemicals, empowering scientists and researchers to drive progress in science and industry.

## Contact

Address: 3281 E Guasti Rd

Ontario, CA 91761, United States

Phone: (601) 213-4426

Email: [info@benchchem.com](mailto:info@benchchem.com)