

# Comparative Analysis of Tricadmium Compounds for Research Applications: A Data-Driven Guide

**Author:** BenchChem Technical Support Team. **Date:** December 2025

## Compound of Interest

Compound Name: *Tricadmium*

Cat. No.: *B15196845*

[Get Quote](#)

For researchers and professionals in drug development and materials science, the selection of inorganic compounds with tailored properties is critical. This guide provides a comparative analysis of **tricadmium** orthophosphate ( $\text{Cd}_3(\text{PO}_4)_2$ ) and, as a well-characterized alternative, cadmium selenide ( $\text{CdSe}$ ), cross-referencing available experimental data with the NIST chemical database and other scientific sources. While the diatomic **tricadmium** ( $\text{Cd}_3$ ) exists primarily in the gas phase with limited available data beyond its ionization energy, this guide will focus on a more stable and experimentally rich **tricadmium** compound to provide a practical comparison for laboratory applications.

The primary entry for **tricadmium** in the NIST Chemistry WebBook specifies its molecular formula as  $\text{Cd}_3$ , a molecular weight of 337.233 g/mol, and a CAS Registry Number of 53809-79-3.[1] The key experimental data point available from NIST is its gas phase ionization energy, determined to be 7.1 eV.[2] Due to the scarcity of further experimental data on this specific intermetallic cluster, we will pivot our detailed comparison to **tricadmium** orthophosphate, a stable compound for which extensive data is available.

## Quantitative Data Comparison

The following table summarizes the key physical and electronic properties of **tricadmium** orthophosphate and cadmium selenide, providing a basis for comparison in material selection.

Property	Tricadmium Orthophosphate (Cd <sub>3</sub> (PO <sub>4</sub> ) <sub>2</sub> )	Cadmium Selenide (CdSe)
CAS Registry Number	13477-17-3	1306-24-7
Molecular Formula	Cd <sub>3</sub> (PO <sub>4</sub> ) <sub>2</sub>	CdSe
Molar Mass	527.18 g/mol	191.37 g/mol
Crystal System	Monoclinic	Hexagonal (Wurtzite) or Cubic (Zincblende)
Band Gap Energy	3.85 eV (Indirect)[3][4]	~1.74 eV (Direct)
Synthesis Method	Hydrothermal, Solid-State Reaction[3][4]	Colloidal Synthesis, Chemical Bath Deposition
Primary Application	Phosphors, Pigments	Quantum Dots, Bioimaging, Solar Cells

## Experimental Protocols

The synthesis and characterization of these materials involve precise experimental procedures. Below are representative protocols for **tricadmium** orthophosphate.

### Synthesis of **Tricadmium** Orthophosphate (Cd<sub>3</sub>(PO<sub>4</sub>)<sub>2</sub>)

- **Hydrothermal Synthesis:** Single crystals of **tricadmium** orthophosphate can be synthesized via the hydrothermal route. This method involves the reaction of soluble cadmium and phosphate precursors in an aqueous solution within a sealed vessel (autoclave) and heated to elevated temperatures and pressures. This process allows for the slow crystallization of the product.
- **Solid-State Synthesis:** A powder form of **tricadmium** orthophosphate is obtainable through a solid-solid process.[3][4] This typically involves the intimate mixing of stoichiometric amounts of cadmium oxide (CdO) and ammonium dihydrogen phosphate (NH<sub>4</sub>H<sub>2</sub>PO<sub>4</sub>) followed by calcination at high temperatures.

### Characterization Techniques

- X-Ray Diffraction (XRD): Used to determine the crystal structure, phase purity, and lattice parameters of the synthesized material. The single-crystal diffraction analysis of  $\beta\text{-Cd}_3(\text{PO}_4)_2$  confirmed a monoclinic system with space group  $P2_1/n$ .[\[3\]](#)[\[4\]](#)
- Scanning Electron Microscopy (SEM): Employed to investigate the surface morphology and microstructure of the material.
- Energy-Dispersive X-ray Spectroscopy (EDX): Used in conjunction with SEM to confirm the elemental composition and stoichiometry of the synthesized compound.
- UV-Visible Spectroscopy: To determine the optical properties, specifically the band gap energy. An absorbance band at 289 nm is observed for  $\beta\text{-Cd}_3(\text{PO}_4)_2$ , and the Kubelka-Munk method can be used to estimate the optical band gap.[\[3\]](#)[\[4\]](#)
- Infrared (IR) Spectroscopy: To identify the functional groups present in the material. For **tricadmium** orthophosphate, IR analysis corroborates the presence of isolated phosphate tetrahedrons in the structure.[\[4\]](#)

## Visualizing Experimental Workflow

The following diagram illustrates a typical experimental workflow for the synthesis and characterization of **tricadmium** orthophosphate.

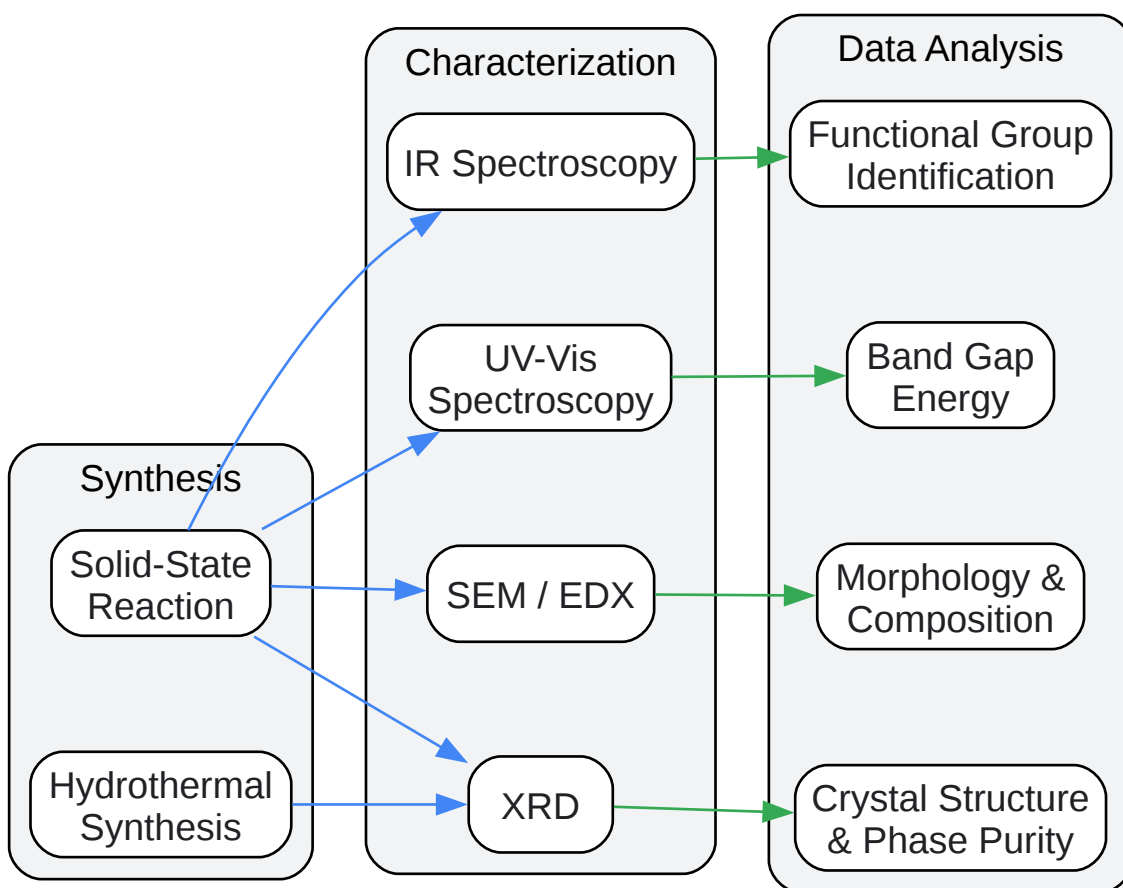

[Click to download full resolution via product page](#)

Caption: Experimental workflow for synthesis and characterization of **tricadmium** orthophosphate.

### Need Custom Synthesis?

BenchChem offers custom synthesis for rare earth carbides and specific isotopic labeling.

Email: [info@benchchem.com](mailto:info@benchchem.com) or [Request Quote Online](#).

## References

- 1. Tricadmium [webbook.nist.gov]
- 2. Tricadmium [webbook.nist.gov]
- 3. journals.iucr.org [journals.iucr.org]

- 4. mdpi.com [mdpi.com]
- To cite this document: BenchChem. [Comparative Analysis of Tricadmium Compounds for Research Applications: A Data-Driven Guide]. BenchChem, [2025]. [Online PDF]. Available at: [<https://www.benchchem.com/product/b15196845#cross-referencing-experimental-data-with-the-nist-chemical-database-for-tricadmium>]

---

### Disclaimer & Data Validity:

The information provided in this document is for Research Use Only (RUO) and is strictly not intended for diagnostic or therapeutic procedures. While BenchChem strives to provide accurate protocols, we make no warranties, express or implied, regarding the fitness of this product for every specific experimental setup.

**Technical Support:** The protocols provided are for reference purposes. Unsure if this reagent suits your experiment? [[Contact our Ph.D. Support Team for a compatibility check](#)]

**Need Industrial/Bulk Grade?** [Request Custom Synthesis Quote](#)

## BenchChem

Our mission is to be the trusted global source of essential and advanced chemicals, empowering scientists and researchers to drive progress in science and industry.

### Contact

Address: 3281 E Guasti Rd

Ontario, CA 91761, United States

Phone: (601) 213-4426

Email: [info@benchchem.com](mailto:info@benchchem.com)