

Comparative Analysis of MRT 68601 Hydrochloride and Amlexanox Selectivity

Author: BenchChem Technical Support Team. **Date:** December 2025

Compound of Interest

Compound Name: MRT 68601 hydrochloride

Cat. No.: B609330

[Get Quote](#)

A Guide for Researchers in Drug Discovery and Development

This guide provides a detailed comparison of the kinase inhibitor selectivity of **MRT 68601 hydrochloride** and Amlexanox, two compounds known to target TANK-binding kinase 1 (TBK1) and I κ B kinase ϵ (IKK ϵ). Both kinases are critical regulators of innate immunity and inflammatory signaling pathways, making them attractive targets for therapeutic intervention in a range of diseases, from autoimmune disorders to cancer. This document is intended for researchers, scientists, and drug development professionals, offering a comprehensive overview of the available data to inform compound selection and experimental design.

Executive Summary

MRT 68601 hydrochloride and Amlexanox are both inhibitors of the non-canonical I κ B kinases, TBK1 and IKK ϵ . However, they exhibit distinct selectivity profiles. **MRT 68601 hydrochloride** is a highly potent inhibitor of TBK1 with a reported IC₅₀ in the low nanomolar range. In contrast, Amlexanox is a less potent, dual inhibitor of both TBK1 and IKK ϵ , with IC₅₀ values in the low micromolar range. While Amlexanox has been shown to be selective against the canonical I κ B kinases IKK α and IKK β , MRT 68601 is reported to have off-target activity on over 20 other kinases within a 10-fold window of its TBK1 affinity. This guide presents a detailed breakdown of their known potencies, selectivity, and the experimental methods used for their characterization.

Data Presentation: Potency and Selectivity

The following tables summarize the available quantitative data for **MRT 68601 hydrochloride** and Amlexanox, focusing on their inhibitory activity against their primary targets and known off-targets.

Table 1: Inhibitory Potency (IC50) against Primary Targets

Compound	Target	IC50
MRT 68601 hydrochloride	TBK1	6 nM[1]
Amlexanox	TBK1	~1-2 µM[2]
IKKε	~1-2 µM[2]	

Table 2: Known Selectivity and Off-Target Profile

Compound	Selectivity Profile	Known Off-Targets
MRT 68601 hydrochloride	Reported to have nanomolar affinities for >20 other kinases within a 10-fold window of its TBK1 binding affinity. A comprehensive, publicly available kinase panel profile is not available.	Specific off-target kinases are not extensively documented in publicly available literature.
Amlexanox	Selective for TBK1/IKKε over the canonical IKKs (IKKα and IKKβ)[2]. A detailed target profile analysis revealed binding to twelve protein targets.	GRK1, GRK5, PDE4B, 5- and 12-lipoxygenases, FGF-1, HSP90, S100A4, S100A12, S100A13

Signaling Pathways

Both MRT 68601 and Amlexanox exert their effects by inhibiting TBK1 and IKKε, which are key kinases in the signaling pathways that lead to the activation of the transcription factors IRF3,

IRF7, and NF- κ B. These pathways are central to the production of type I interferons and other inflammatory mediators in response to pathogens and other stimuli.

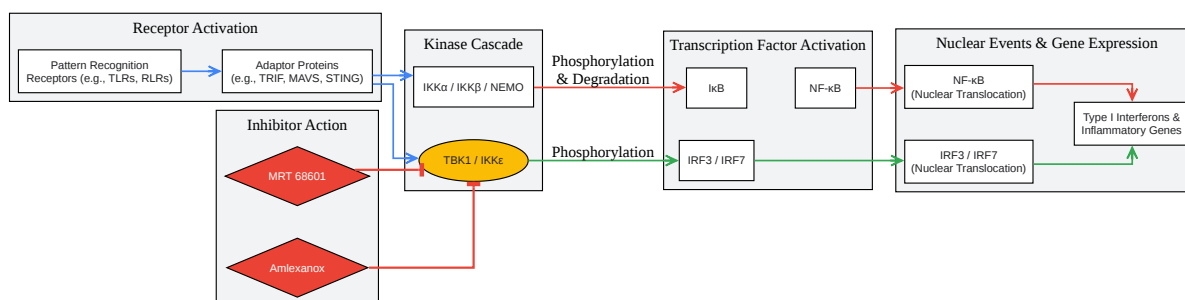

[Click to download full resolution via product page](#)

TBK1/IKK ϵ Signaling Pathway and Points of Inhibition.

Experimental Protocols

The determination of inhibitor potency and selectivity is critical for the characterization of kinase inhibitors. Below are detailed methodologies for common in vitro kinase assays relevant to the evaluation of compounds like MRT 68601 and Amlexanox.

Radiometric Kinase Assay (e.g., for TBK1)

This method measures the transfer of a radiolabeled phosphate from [γ - 32 P]ATP to a substrate by the kinase.

Materials:

- Recombinant human TBK1 enzyme

- Myelin Basic Protein (MBP) or a specific peptide substrate
- Kinase Assay Buffer (e.g., 40 mM Tris-HCl pH 7.5, 20 mM MgCl₂, 0.1 mg/mL BSA, 50 μM DTT)[3]
- [γ -³²P]ATP
- Unlabeled ATP
- Test compounds (MRT 68601 or Amlexanox) dissolved in DMSO
- P81 phosphocellulose paper
- 0.75% Phosphoric acid
- Scintillation counter

Procedure:

- Prepare serial dilutions of the test compound in DMSO.
- In a reaction tube, combine the kinase assay buffer, substrate (e.g., MBP at 0.2 mg/mL), and the diluted test compound or DMSO (for control).
- Add the recombinant TBK1 enzyme to the reaction mixture and pre-incubate for 10-20 minutes at room temperature.
- Initiate the kinase reaction by adding a mixture of unlabeled ATP and [γ -³²P]ATP to a final concentration that is at or near the K_m of ATP for the kinase.
- Incubate the reaction at 30°C for a defined period (e.g., 30-60 minutes), ensuring the reaction is in the linear range.
- Stop the reaction by spotting a portion of the reaction mixture onto P81 phosphocellulose paper.
- Wash the P81 paper extensively with 0.75% phosphoric acid to remove unincorporated [γ -³²P]ATP.

- Measure the incorporated radioactivity on the P81 paper using a scintillation counter.
- Calculate the percentage of kinase inhibition for each compound concentration relative to the DMSO control.
- Determine the IC50 value by fitting the data to a dose-response curve using appropriate software.

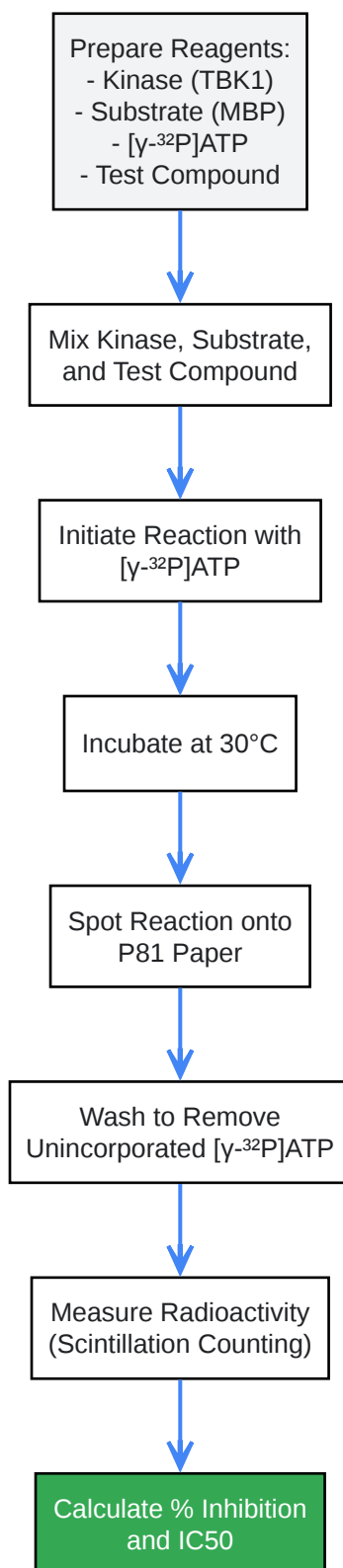

[Click to download full resolution via product page](#)

Workflow for a Radiometric Kinase Assay.

ADP-Glo™ Kinase Assay (Luminescence-based)

This assay quantifies kinase activity by measuring the amount of ADP produced in the kinase reaction.

Materials:

- Recombinant human TBK1 or IKKε enzyme
- Appropriate substrate
- Kinase Assay Buffer
- ATP
- Test compounds
- ADP-Glo™ Reagent
- Kinase Detection Reagent

Procedure:

- Set up the kinase reaction in a multi-well plate containing the kinase, substrate, ATP, and the test compound at various concentrations.
- Incubate the reaction at room temperature for a specified time (e.g., 60 minutes)[3].
- Add the ADP-Glo™ Reagent to stop the kinase reaction and deplete the remaining ATP.
- Incubate for 40 minutes at room temperature[3].
- Add the Kinase Detection Reagent to convert the ADP to ATP and generate a luminescent signal via a luciferase reaction.
- Incubate for 30-60 minutes at room temperature.
- Measure the luminescence using a plate reader. The luminescent signal is proportional to the amount of ADP produced and thus to the kinase activity.

- Calculate the IC50 values from the dose-response curves.

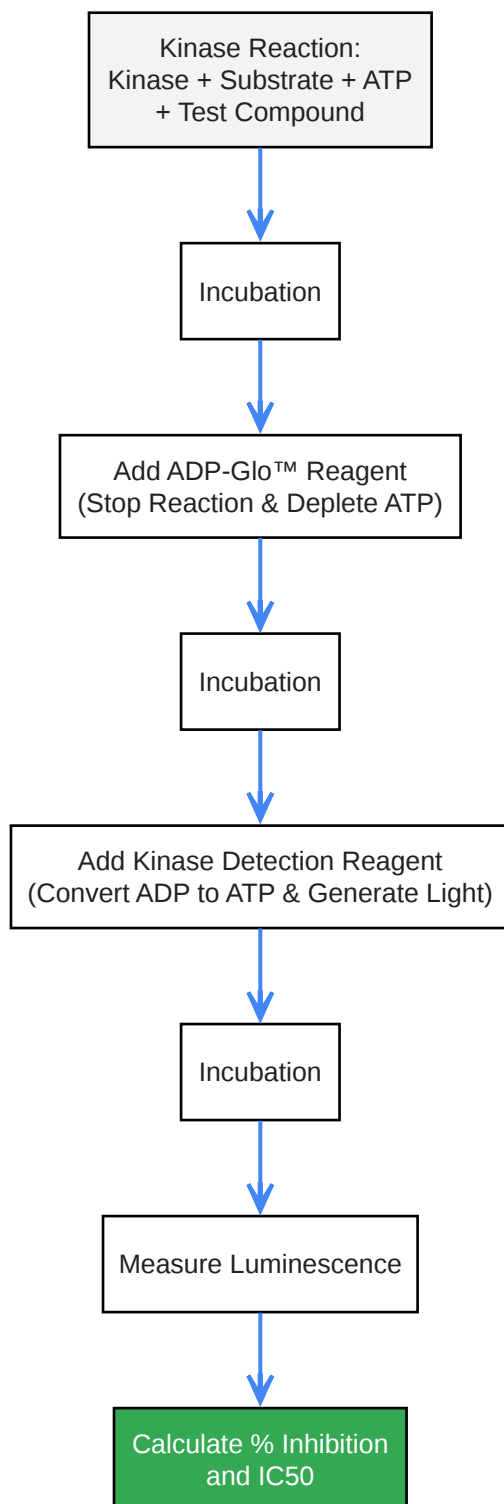

[Click to download full resolution via product page](#)

Workflow for an ADP-Glo™ Kinase Assay.

Conclusion

The choice between **MRT 68601 hydrochloride** and Amlexanox will depend on the specific research question and experimental context. MRT 68601 offers high potency for TBK1 inhibition, which may be desirable for studies focused on the specific roles of this kinase. However, its potential for off-target effects should be carefully considered and controlled for in experimental designs. Amlexanox, while less potent, provides dual inhibition of TBK1 and IKKε and has a better-characterized selectivity profile with known off-targets outside of the kinase family. Its established clinical use for other indications also provides a wealth of safety and pharmacological data. For studies requiring highly selective inhibition of TBK1/IKKε, further profiling of MRT 68601 or the use of more recently developed and characterized inhibitors may be warranted. Researchers should carefully evaluate the data presented in this guide and consult the primary literature to make an informed decision for their specific application.

Need Custom Synthesis?

BenchChem offers custom synthesis for rare earth carbides and specific isotopic labeling.

Email: info@benchchem.com or [Request Quote Online](#).

References

- 1. medchemexpress.com [medchemexpress.com]
- 2. A high-throughput radiometric kinase assay - PMC [pmc.ncbi.nlm.nih.gov]
- 3. promega.com [promega.com]
- To cite this document: BenchChem. [Comparative Analysis of MRT 68601 Hydrochloride and Amlexanox Selectivity]. BenchChem, [2025]. [Online PDF]. Available at: [https://www.benchchem.com/product/b609330#selectivity-of-mrt-68601-hydrochloride-compared-to-amlexanox]

Disclaimer & Data Validity:

The information provided in this document is for Research Use Only (RUO) and is strictly not intended for diagnostic or therapeutic procedures. While BenchChem strives to provide

accurate protocols, we make no warranties, express or implied, regarding the fitness of this product for every specific experimental setup.

Technical Support: The protocols provided are for reference purposes. Unsure if this reagent suits your experiment? [[Contact our Ph.D. Support Team for a compatibility check](#)]

Need Industrial/Bulk Grade? [Request Custom Synthesis Quote](#)

BenchChem

Our mission is to be the trusted global source of essential and advanced chemicals, empowering scientists and researchers to drive progress in science and industry.

Contact

Address: 3281 E Guasti Rd

Ontario, CA 91761, United States

Phone: (601) 213-4426

Email: info@benchchem.com