

Common mistakes to avoid when using ATP-Red 1

Author: BenchChem Technical Support Team. **Date:** December 2025

Compound of Interest

Compound Name: ATP-Red 1

Cat. No.: B560525

[Get Quote](#)

ATP-Red 1 Technical Support Center

Welcome to the technical support center for **ATP-Red 1**, a fluorescent probe for the detection of intracellular ATP. This resource is designed for researchers, scientists, and drug development professionals to provide troubleshooting guidance and answers to frequently asked questions to ensure successful experimentation.

Frequently Asked Questions (FAQs)

Q1: What is **ATP-Red 1** and how does it work?

ATP-Red 1 is a cell-permeable fluorescent probe designed to selectively detect adenosine triphosphate (ATP) within living cells.[1][2] Its mechanism is based on a multi-site binding interaction with the ATP molecule, which induces a conformational change in the probe, leading to a significant increase in its fluorescence intensity.[1][3] In its unbound state, **ATP-Red 1** is weakly fluorescent.[4]

Q2: What are the excitation and emission wavelengths for **ATP-Red 1**?

The optimal excitation and emission wavelengths for **ATP-Red 1** are approximately 510 nm and 590 nm, respectively. Some sources may report slight variations, such as an absorption maximum at 570/566 nm and an emission maximum at 590/585 nm.

Q3: In which cellular compartment does **ATP-Red 1** primarily localize?

ATP-Red 1 predominantly localizes in the mitochondria. This is attributed to the high concentration of ATP in this organelle, which is the primary site of cellular respiration and ATP synthesis.

Q4: Is **ATP-Red 1** selective for ATP over other nucleotides like ADP and AMP?

ATP-Red 1 exhibits good selectivity for ATP over adenosine diphosphate (ADP) and adenosine monophosphate (AMP). While ADP and AMP can induce a slight increase in fluorescence, the response is significantly lower than that observed with ATP. The probe also shows minimal cross-reactivity with other biomolecules such as various metal ions and carbohydrates.

Q5: Can **ATP-Red 1** be used in flow cytometry?

Yes, **ATP-Red 1** can be utilized for flow cytometry to analyze and sort cell populations based on their intracellular ATP levels.

Troubleshooting Guide

Problem 1: Weak or No Fluorescent Signal

Q: I am not observing any signal, or the signal is very weak. What could be the cause?

A: Several factors can contribute to a weak or absent fluorescent signal. Consider the following potential causes and solutions:

- **Suboptimal Probe Concentration:** The concentration of **ATP-Red 1** may be too low. It is recommended to perform a titration to determine the optimal concentration for your specific cell type and experimental conditions.
- **Incorrect Filter Sets:** Ensure that the excitation and emission filters on your microscope or flow cytometer are appropriate for the spectral properties of **ATP-Red 1** (Ex/Em \approx 510/590 nm).
- **Low Intracellular ATP Levels:** The cells may have depleted ATP levels. This can be due to cell stress, nutrient deprivation, or treatment with metabolic inhibitors. Consider using a positive control of healthy, metabolically active cells.

- **Insufficient Incubation Time:** The incubation time may not be sufficient for the probe to penetrate the cells and bind to ATP. Optimize the incubation time, typically ranging from 15 to 30 minutes.
- **Improper Storage of **ATP-Red 1**:** Ensure the probe has been stored correctly, protected from light, and has not undergone repeated freeze-thaw cycles.

Problem 2: High Background Fluorescence

Q: My images have high background fluorescence, making it difficult to distinguish the signal. How can I reduce it?

A: High background can obscure your signal and is often caused by the following:

- **Excess Probe Concentration:** Using too high a concentration of **ATP-Red 1** can lead to non-specific binding and high background. Titrate the probe to find the lowest effective concentration.
- **Inadequate Washing:** Ensure that cells are thoroughly washed with a suitable buffer (e.g., PBS) after incubation with **ATP-Red 1** to remove any unbound probe.
- **Autofluorescence:** Some cell types or media components (like phenol red) can exhibit autofluorescence. Image unstained cells under the same conditions to assess the level of autofluorescence and consider using phenol red-free media.
- **Contaminated Reagents or Consumables:** Use high-quality, clean reagents and consumables to avoid fluorescent contaminants.

Problem 3: Photobleaching

Q: The fluorescent signal fades quickly during imaging. What can I do to prevent this?

A: Photobleaching is the photochemical destruction of a fluorophore upon exposure to excitation light. To minimize this effect:

- **Reduce Exposure Time and Intensity:** Use the lowest possible excitation light intensity and the shortest exposure time that still provides a detectable signal.

- **Minimize Exposure:** Avoid prolonged exposure of the sample to the excitation light. Use the brightfield channel to locate and focus on the cells before switching to the fluorescence channel for image acquisition.
- **Use an Antifade Mounting Medium:** For fixed-cell imaging, using a mounting medium containing an antifade reagent can help to reduce photobleaching.

Problem 4: Inconsistent or Unexpected Results

Q: I am getting variable results between experiments or observing unexpected changes in fluorescence.

A: Inconsistent results can be due to a variety of factors:

- **Cell Health and Density:** Ensure that cells are healthy, in the exponential growth phase, and plated at a consistent density for all experiments. Cell stress can significantly impact ATP levels.
- **Experimental Conditions:** Maintain consistent experimental parameters such as temperature, incubation times, and reagent concentrations across all samples and experiments.
- **Presence of Inhibitors or Activators:** Be aware that components in your experimental treatment may interfere with cellular metabolism, thereby altering ATP levels. For example, KCN is an inhibitor of oxidative phosphorylation and can reduce mitochondrial ATP levels.

Quantitative Data

Table 1: Recommended Experimental Parameters for **ATP-Red 1**

| Parameter | Recommended Range/Value | Notes |
|------------------------------|--------------------------|---|
| Stock Solution Concentration | 1-10 mM in DMSO | Aliquot and store at -20°C or -80°C to avoid repeat freeze-thaw cycles. |
| Working Concentration | 1-10 µM | Optimal concentration should be determined empirically for each cell type. |
| Incubation Time | 15-30 minutes | Longer times may be needed for certain cell types or for live-cell imaging. |
| Incubation Temperature | Room Temperature or 37°C | 37°C is generally preferred for live-cell experiments. |
| Excitation Wavelength | ~510 nm | Can vary slightly depending on the instrument. |
| Emission Wavelength | ~590 nm | Can vary slightly depending on the instrument. |

Table 2: Selectivity of **ATP-Red 1**

| Analyte (5 mM) | Fluorescence Intensity Increase (Fold Change) |
|--|---|
| ATP | 5.6 |
| ADP | Slight increase |
| AMP | Slight increase |
| Various Metal Ions (e.g., Zn ²⁺ , Mg ²⁺ , Ca ²⁺) | No significant increase |
| Various Carbohydrates (e.g., glucose, fructose) | No significant increase |
| Other Nucleoside Triphosphates (GTP, CTP, UTP) | Slight increase |

(Data synthesized from reference)

Experimental Protocols

Detailed Methodology for Fluorescence Microscopy

- Cell Preparation:
 - Plate cells on a suitable imaging dish or slide (e.g., glass-bottom dish) and culture until they reach the desired confluency.
- Preparation of **ATP-Red 1** Working Solution:
 - Thaw a vial of **ATP-Red 1** stock solution (typically 1-10 mM in DMSO) at room temperature.
 - Dilute the stock solution in serum-free medium or PBS to the desired final working concentration (e.g., 5 μM). The working solution should be prepared fresh and protected from light.
- Staining:
 - Remove the culture medium from the cells and wash once with warm PBS.

- Add the **ATP-Red 1** working solution to the cells and incubate for 15-30 minutes at 37°C, protected from light.
- Washing:
 - Remove the staining solution and wash the cells two to three times with warm PBS or serum-free medium to remove any unbound probe.
- Imaging:
 - Add fresh, pre-warmed imaging medium (phenol red-free is recommended) to the cells.
 - Image the cells using a fluorescence microscope equipped with appropriate filters for **ATP-Red 1** (Ex/Em ≈ 510/590 nm).

Detailed Methodology for Flow Cytometry

- Cell Preparation:
 - Harvest cells and prepare a single-cell suspension at a concentration of approximately 1×10^6 cells/mL in a suitable buffer (e.g., PBS).
- Preparation of **ATP-Red 1** Working Solution:
 - Prepare a 2X working solution of **ATP-Red 1** in serum-free medium or PBS.
- Staining:
 - Add an equal volume of the 2X **ATP-Red 1** working solution to the cell suspension.
 - Incubate for 15-30 minutes at 37°C, protected from light.
- Washing:
 - Centrifuge the cells to pellet, remove the supernatant, and resuspend the cell pellet in fresh buffer.
 - Repeat the wash step two to three times.

- Analysis:
 - Resuspend the final cell pellet in a suitable buffer for flow cytometry.
 - Analyze the cells on a flow cytometer using the appropriate laser and emission filter for **ATP-Red 1** (e.g., a blue laser for excitation and a PE-Texas Red or similar channel for emission).

Visualizations

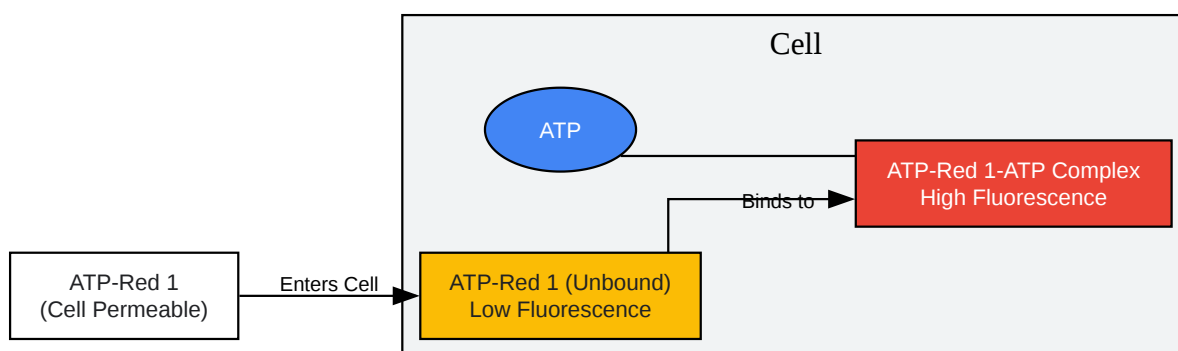

[Click to download full resolution via product page](#)

Caption: Mechanism of **ATP-Red 1** fluorescence activation upon binding to intracellular ATP.

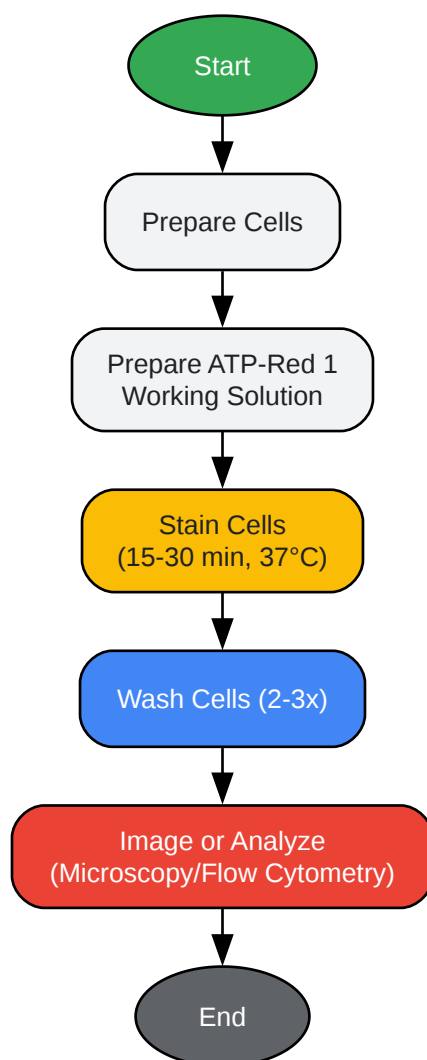

[Click to download full resolution via product page](#)

Caption: General experimental workflow for using **ATP-Red 1**.

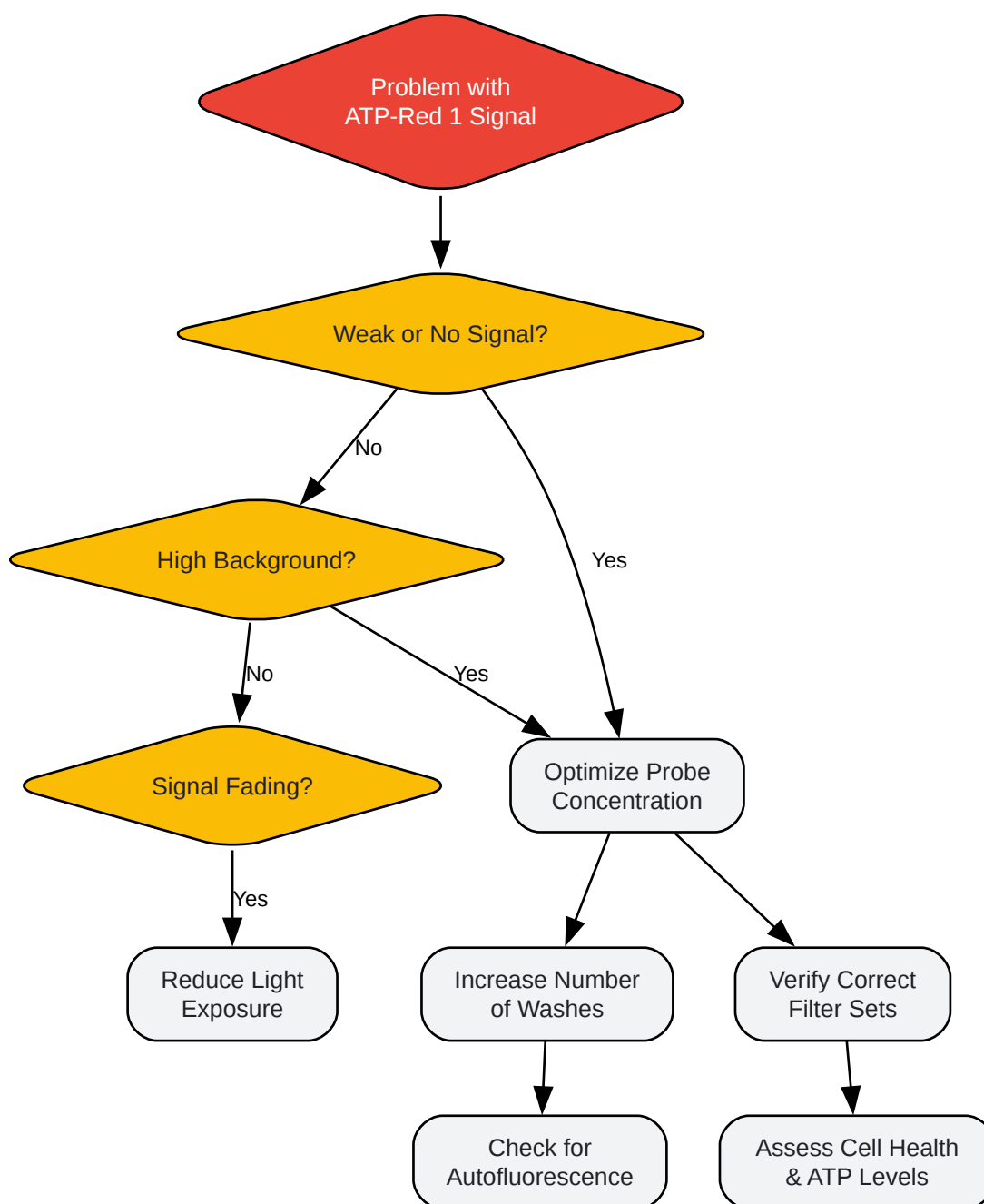

[Click to download full resolution via product page](#)

Caption: A logical troubleshooting guide for common issues with **ATP-Red 1**.

Need Custom Synthesis?

BenchChem offers custom synthesis for rare earth carbides and specific isotopic labeling.

Email: info@benchchem.com or [Request Quote Online](#).

References

- 1. researchgate.net [researchgate.net]
- 2. medchemexpress.com [medchemexpress.com]
- 3. sigmaaldrich.com [sigmaaldrich.com]
- 4. researchgate.net [researchgate.net]
- To cite this document: BenchChem. [Common mistakes to avoid when using ATP-Red 1]. BenchChem, [2025]. [Online PDF]. Available at: [https://www.benchchem.com/product/b560525#common-mistakes-to-avoid-when-using-atp-red-1]

Disclaimer & Data Validity:

The information provided in this document is for Research Use Only (RUO) and is strictly not intended for diagnostic or therapeutic procedures. While BenchChem strives to provide accurate protocols, we make no warranties, express or implied, regarding the fitness of this product for every specific experimental setup.

Technical Support: The protocols provided are for reference purposes. Unsure if this reagent suits your experiment? [[Contact our Ph.D. Support Team for a compatibility check](#)]

Need Industrial/Bulk Grade? [Request Custom Synthesis Quote](#)

BenchChem

Our mission is to be the trusted global source of essential and advanced chemicals, empowering scientists and researchers to drive progress in science and industry.

Contact

Address: 3281 E Guasti Rd
Ontario, CA 91761, United States
Phone: (601) 213-4426
Email: info@benchchem.com