

Common experimental artifacts with Iganidipine treatment

Author: BenchChem Technical Support Team. **Date:** December 2025

Compound of Interest

Compound Name: Iganidipine

Cat. No.: B044766

[Get Quote](#)

Technical Support Center: Iganidipine Treatment

This technical support center provides troubleshooting guides and frequently asked questions (FAQs) for researchers, scientists, and drug development professionals working with **Iganidipine**. The content is designed to address common experimental challenges and provide detailed protocols and guidance for obtaining reliable and reproducible results.

Frequently Asked Questions (FAQs)

Q1: What is **Iganidipine** and what is its primary mechanism of action?

A1: **Iganidipine** is a dihydropyridine derivative that functions as a calcium channel antagonist. Its primary mechanism of action is the blockade of L-type voltage-gated calcium channels, which are crucial for the excitation-contraction coupling in smooth and cardiac muscle.[1] By inhibiting the influx of calcium into these cells, **Iganidipine** leads to vasodilation and a reduction in cardiac contractility.[1] This makes it a subject of interest in cardiovascular research.

Q2: **Iganidipine** is described as "water-soluble," but I am observing precipitation in my experiments. Why might this be happening?

A2: While **Iganidipine** is noted for its water solubility, especially in comparison to other dihydropyridines, several factors can lead to precipitation in an experimental setting:

- **Concentration:** Exceeding the solubility limit in your specific buffer or cell culture medium can cause the compound to fall out of solution.
- **pH of the Medium:** The solubility of many compounds is pH-dependent. A change in the pH of your experimental medium could reduce **Iganidipine**'s solubility.
- **Temperature:** Changes in temperature during storage or incubation can affect solubility.
- **Buffer Composition:** The presence of certain salts or proteins in your buffer system could interact with **Iganidipine** and reduce its solubility. It is advisable to prepare high-concentration stock solutions in an appropriate solvent (like DMSO) and then dilute to the final concentration in your aqueous experimental medium immediately before use.

Q3: How should I prepare and store **Iganidipine** stock solutions?

A3: For optimal stability and to avoid solubility issues, follow these guidelines:

- **Stock Solution:** Prepare a high-concentration stock solution (e.g., 10 mM) in a high-quality, anhydrous solvent such as dimethyl sulfoxide (DMSO).
- **Storage:** Store the stock solution at -20°C or -80°C in small aliquots to avoid repeated freeze-thaw cycles. Protect from light, as dihydropyridines can be light-sensitive.
- **Working Solution:** On the day of the experiment, thaw an aliquot of the stock solution and dilute it to the final desired concentration in your pre-warmed cell culture medium or buffer. Ensure thorough mixing. Do not store diluted aqueous solutions for extended periods.

Q4: Are there known off-target effects or potential for assay interference with **Iganidipine**?

A4: Specific off-target screening data for **Iganidipine** is not widely available. However, based on the properties of similar dihydropyridine compounds like amlodipine, researchers should be aware of the following potential interferences:

- **Autofluorescence:** Some dihydropyridines exhibit intrinsic fluorescence.^[2] This can be a significant artifact in fluorescence-based assays, such as calcium imaging with fluorescent dyes (e.g., Fluo-4, Fura-2) or cell viability assays that use fluorescent readouts (e.g.,

resazurin). It is crucial to run control experiments with **Iganidipine** alone (without the fluorescent dye) to measure its background fluorescence at the relevant wavelengths.[2]

- Interaction with Assay Reagents: Like any small molecule, **Iganidipine** could potentially interact directly with assay components. For example, in cell viability assays like the MTT assay, a compound could affect cellular metabolic activity or the enzymes responsible for reducing the tetrazolium salt, independent of its effect on cell viability.[3] It is always recommended to confirm key findings with an orthogonal assay that relies on a different detection principle.

Quantitative Data Summary

Specific quantitative physicochemical and pharmacological data for **Iganidipine** are not readily available in the public literature. The following table summarizes typical data for other well-characterized dihydropyridine L-type calcium channel blockers to provide an approximate reference range for experimental design.

Property	Amlodipine	Felodipine	Cilnidipine	Lercanidipine	Expected Range for Iganidipine
Molecular Weight	408.9 g/mol [4]	384.2 g/mol [5]	492.5 g/mol [6]	611.7 g/mol [7]	~400-600 g/mol
LogP	3.0[4]	3.86[5]	4.7[6]	6.4[7]	Likely moderately to highly lipophilic
Aqueous Solubility	Slightly soluble[4]	19.7 mg/L[5]	Insoluble[6]	0.156 mg/L[7]	Variable, but noted as "water-soluble"
IC ₅₀ (L-type Ca ²⁺ channel)	0.229 μM (rat cardiomyocytes)[8]	N/A	< 10 nM (A7r5 cells)	0.5 nM (human arteries)	Sub-micromolar to low nanomolar

Troubleshooting Guides

Electrophysiology (Patch Clamp) Experiments

Issue: Weak or no inhibition of L-type calcium currents after **Iganidipine** application.

Possible Cause	Troubleshooting Steps
Drug Degradation/Precipitation	Prepare fresh dilutions of Iganidipine from a frozen stock for each experiment. Visually inspect the final solution for any signs of precipitation.
Incorrect Drug Concentration	Verify the calculations for your dilutions. Based on related compounds, the IC ₅₀ is likely in the nM to low μM range.[8] Perform a dose-response curve to determine the optimal concentration.
Slow On-Rate	Some lipophilic dihydropyridines have a slow onset of action. Ensure you are perfusing the drug for a sufficient duration to allow it to reach its binding site and achieve steady-state block.
Voltage-Dependence of Block	Dihydropyridine block is voltage-dependent, with higher affinity for inactivated channels. The blocking effect will be more pronounced at depolarized holding potentials. Ensure your voltage protocol is appropriate for observing L-type channel activity and its inhibition.
Poor Gigaseal or Cell Health	Unstable recordings or low current amplitude can mask the effect of the drug. Ensure you have a high-resistance seal (>1 GΩ) and that the cell is healthy (stable resting membrane potential, low leak current).

Calcium Imaging Experiments

Issue: Unexpected increase in fluorescence signal after **Iganidipine** application.

Possible Cause	Troubleshooting Steps
Iganidipine Autofluorescence	Iganidipine may be fluorescent at the excitation/emission wavelengths of your calcium indicator. Control Experiment: Perfuse cells with Iganidipine without loading them with the calcium dye. Any signal detected is from the drug itself and must be subtracted from your experimental data.
Solvent Effects	The vehicle (e.g., DMSO) used to dissolve Iganidipine might have an effect on the cells or the dye. Run a vehicle control where you apply the same concentration of DMSO without the drug.
Off-Target Effects	Iganidipine could be causing calcium release from internal stores through an off-target mechanism. This is less likely for a specific L-type blocker but can be tested by performing the experiment in a calcium-free external solution to isolate intracellular effects.

Western Blotting for Downstream Signaling

Issue: No change in the phosphorylation status of downstream proteins after **Iganidipine** treatment.

Possible Cause	Troubleshooting Steps
Suboptimal Treatment Conditions	The duration of treatment or the concentration of lganidipine may be insufficient to elicit a measurable downstream effect. Optimize both through time-course and dose-response experiments.
Cell Line Unresponsive	The specific signaling pathway you are investigating may not be strongly modulated by L-type calcium channel activity in your chosen cell line. Confirm that your cells express L-type calcium channels and that these channels are active under your culture conditions.
Protein Degradation or Poor Lysis	Ensure that lysis buffers contain fresh protease and phosphatase inhibitors to preserve the phosphorylation status of your target proteins.
General Western Blot Issues	Refer to standard Western blot troubleshooting guides for issues like poor antibody quality, inefficient protein transfer, or incorrect blocking/washing steps.

Experimental Protocols & Visualizations

Key Signaling Pathway: L-Type Calcium Channel Blockade

The primary mechanism of **lganidipine** involves blocking the L-type calcium channel (Ca V 1.2) on the plasma membrane of excitable cells like vascular smooth muscle cells. This prevents the influx of extracellular Ca²⁺ that is necessary for triggering muscle contraction.

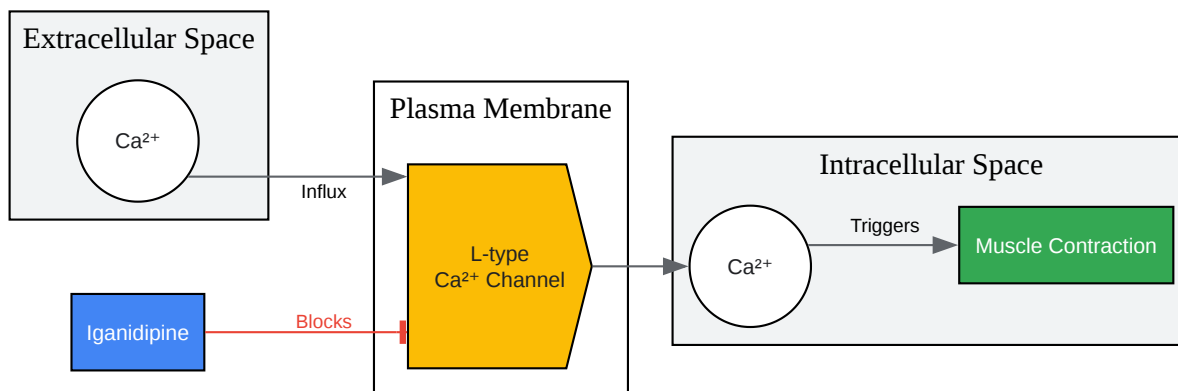

[Click to download full resolution via product page](#)

Caption: **Iganidipine** blocks L-type calcium channels, inhibiting Ca²⁺ influx and muscle contraction.

General Troubleshooting Workflow

This workflow provides a logical sequence for diagnosing issues in experiments involving **Iganidipine** treatment.

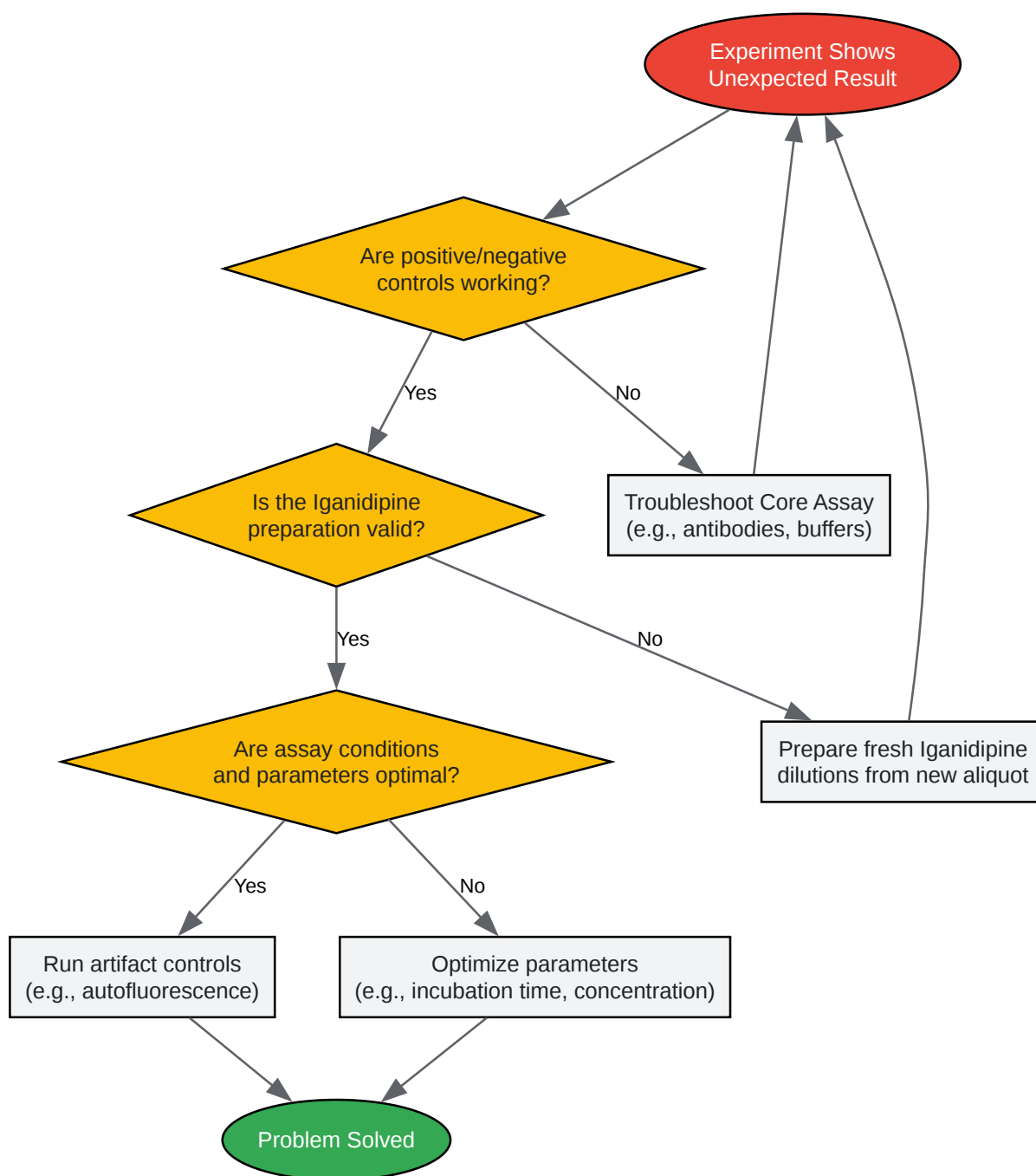

[Click to download full resolution via product page](#)

Caption: A logical workflow for troubleshooting common experimental issues with **Iganidipine**.

Protocol 1: Patch Clamp Electrophysiology for I_{Ca,L} Inhibition

This protocol outlines the measurement of L-type calcium currents ($I_{Ca,L}$) in a voltage-clamp experiment.

- Cell Preparation: Culture cells known to express L-type calcium channels (e.g., HEK293 cells transfected with Ca_v1.2, or primary vascular smooth muscle cells) on glass coverslips suitable for electrophysiology.
- Solutions:
 - External Solution (in mM): 135 TEA-Cl, 10 BaCl₂ (or CaCl₂), 1 MgCl₂, 10 HEPES, 10 Glucose. Adjust to pH 7.4 with CsOH. Barium is often used instead of calcium to increase current amplitude and reduce calcium-dependent inactivation.
 - Internal (Pipette) Solution (in mM): 120 CsCl, 10 EGTA, 10 HEPES, 5 Mg-ATP, 0.1 Na-GTP. Adjust to pH 7.2 with CsOH.
- Recording:
 - Establish a whole-cell patch clamp configuration.
 - Hold the cell at a negative potential (e.g., -80 mV) to keep channels in a closed, resting state.
 - Apply depolarizing voltage steps (e.g., to 0 mV for 200 ms) to elicit inward Ba²⁺ currents through L-type channels.
 - Establish a stable baseline recording of the current for several minutes.
- **Iganidipine** Application:
 - Prepare **Iganidipine** in the external solution at the desired final concentration immediately before application.
 - Perfuse the cell with the **Iganidipine**-containing solution.
 - Continuously monitor the current amplitude with repeated voltage steps.
 - Allow sufficient time (e.g., 5-10 minutes) for the drug effect to reach a steady state.

- Data Analysis:
 - Measure the peak inward current before (control) and after drug application.
 - Calculate the percentage of inhibition: $(1 - (I_{\text{drug}} / I_{\text{control}})) * 100\%$.
 - Perform a washout by perfusing with the drug-free external solution to assess the reversibility of the block.

Protocol 2: Control for Autofluorescence in Calcium Imaging

This protocol is essential to determine if **Iganidipine** itself contributes to the fluorescence signal in your imaging experiments.

- Cell Preparation: Plate cells on an imaging-quality glass-bottom dish or chamber slide.
- Mock Loading: Prepare two groups of cells from the same plating.
 - Group 1 (Experimental): Load with your fluorescent calcium indicator (e.g., Fluo-4 AM) according to the manufacturer's protocol.
 - Group 2 (Control): "Mock-load" this group by incubating with the same loading buffer but containing only the vehicle (e.g., DMSO) instead of the dye.
- Imaging:
 - Wash both groups with imaging buffer (e.g., HBSS).
 - Place the dish on the fluorescence microscope and acquire a baseline recording from both groups using the same filter set and acquisition parameters (e.g., excitation/emission wavelengths, exposure time).
 - Apply **Iganidipine** at the highest concentration you plan to use in your experiments to both groups.
 - Record the fluorescence signal over the same time course as your planned experiment.

- Data Analysis:
 - In Group 2 (Control), any increase in fluorescence intensity upon **Iganidipine** application is due to the drug's autofluorescence.
 - This autofluorescence signal can be averaged and subtracted from the signal recorded in Group 1 (Experimental) to correct for the artifact. If the autofluorescence is very high, consider using a different calcium indicator that excites/emits at different wavelengths.

Need Custom Synthesis?

BenchChem offers custom synthesis for rare earth carbides and specific isotopic labeling.

Email: info@benchchem.com or [Request Quote Online](#).

References

- 1. L-type calcium channel - Wikipedia [en.wikipedia.org]
- 2. Structural basis for inhibition of a voltage-gated Ca²⁺ channel by Ca²⁺ antagonist drugs - PMC [pmc.ncbi.nlm.nih.gov]
- 3. Amlodipine | C₂₀H₂₅ClN₂O₅ | CID 2162 - PubChem [pubchem.ncbi.nlm.nih.gov]
- 4. Felodipine | C₁₈H₁₉Cl₂N₂O₄ | CID 3333 - PubChem [pubchem.ncbi.nlm.nih.gov]
- 5. Cilnidipine | C₂₇H₂₈N₂O₇ | CID 5282138 - PubChem [pubchem.ncbi.nlm.nih.gov]
- 6. Lercanidipine | C₃₆H₄₁N₃O₆ | CID 65866 - PubChem [pubchem.ncbi.nlm.nih.gov]
- 7. Comparison of electrophysiological effects of calcium channel blockers on cardiac repolarization - PMC [pmc.ncbi.nlm.nih.gov]
- 8. Pharmacology of L-type Calcium Channels: Novel Drugs for Old Targets? - PMC [pmc.ncbi.nlm.nih.gov]
- To cite this document: BenchChem. [Common experimental artifacts with Iganidipine treatment]. BenchChem, [2025]. [Online PDF]. Available at: [https://www.benchchem.com/product/b044766#common-experimental-artifacts-with-iganidipine-treatment]

Disclaimer & Data Validity:

The information provided in this document is for Research Use Only (RUO) and is strictly not intended for diagnostic or therapeutic procedures. While BenchChem strives to provide accurate protocols, we make no warranties, express or implied, regarding the fitness of this product for every specific experimental setup.

Technical Support: The protocols provided are for reference purposes. Unsure if this reagent suits your experiment? [[Contact our Ph.D. Support Team for a compatibility check](#)]

Need Industrial/Bulk Grade? [Request Custom Synthesis Quote](#)

BenchChem

Our mission is to be the trusted global source of essential and advanced chemicals, empowering scientists and researchers to drive progress in science and industry.

Contact

Address: 3281 E Guasti Rd
Ontario, CA 91761, United States
Phone: (601) 213-4426
Email: info@benchchem.com