

Ciprofibrate vs. gemfibrozil: efficacy and safety in preclinical models

Author: BenchChem Technical Support Team. **Date:** December 2025

Compound of Interest

Compound Name: Ciprofibrate

Cat. No.: B1669075

[Get Quote](#)

A Comparative Guide to the Preclinical Efficacy and Safety of **Ciprofibrate** and Gemfibrozil

For researchers and drug development professionals, understanding the nuanced differences between hypolipidemic agents in preclinical settings is paramount for translational success. **Ciprofibrate** and gemfibrozil, both members of the fibrate class of drugs, are widely used to manage dyslipidemia. Their primary mechanism of action involves the activation of Peroxisome Proliferator-Activated Receptor Alpha (PPAR α), a nuclear receptor that regulates the transcription of genes involved in lipid metabolism.^{[1][2][3]} Despite a shared mechanism, preclinical studies reveal distinct profiles in their efficacy and safety.

Comparative Efficacy in Preclinical Models

The lipid-modifying effects of **ciprofibrate** and gemfibrozil have been assessed in various preclinical models, most commonly in rodents with diet-induced or chemically-induced dyslipidemia.^{[4][5][6][7]} Both drugs consistently demonstrate an ability to lower plasma triglycerides and raise High-Density Lipoprotein (HDL) cholesterol.

Table 1: Efficacy in Rodent Models of Dyslipidemia

Parameter	Animal Model	Ciprofibrate	Gemfibrozil
Plasma Triglycerides	High-Fat Diet Rats	Significant Reduction	Significant Reduction[8]
VLDL Cholesterol	High-Fat Diet Rats	Significant Reduction[9]	Significant Reduction[8]
Total Cholesterol	High-Fat Diet Rats	↓ 17-20%[9][10]	↓ ~20%[8]
LDL Cholesterol	High-Fat Diet Rats	↓ 22-24%[9][10]	↓ ~20%[8]
HDL Cholesterol	High-Fat Diet Rats	↑ ~10%[9][10]	Significant Increase[11]

Comparative Safety in Preclinical Models

A critical aspect of fibrate evaluation is their safety profile, particularly concerning the liver. In rodents, fibrates are known to cause peroxisome proliferation and hepatomegaly, effects that are linked to their potent activation of rodent PPAR α . Long-term studies in rats have also raised concerns about hepatocarcinogenicity.[2][12]

Table 2: Safety and Toxicity in Rodent Models

Parameter	Animal Model	Ciprofibrate	Gemfibrozil
Hepatomegaly (Liver Enlargement)	Rats	Marked Increase	Moderate Increase[2]
Peroxisome Proliferation	Rats	Potent Inducer	Inducer[2]
Hepatocellular Tumors (Long-term)	Rats	Increased Incidence	Increased Incidence[12]

It is important to note that the hepatocarcinogenic effects observed in rodents are generally considered not to be predictive of human risk, as humans are significantly less responsive to the peroxisome proliferative effects of PPAR α agonists.[2][12]

Signaling Pathway and Experimental Workflow

The therapeutic effects of both **ciprofibrate** and gemfibrozil are mediated through the activation of PPAR α . This activation leads to a cascade of downstream events that collectively improve the lipid profile.

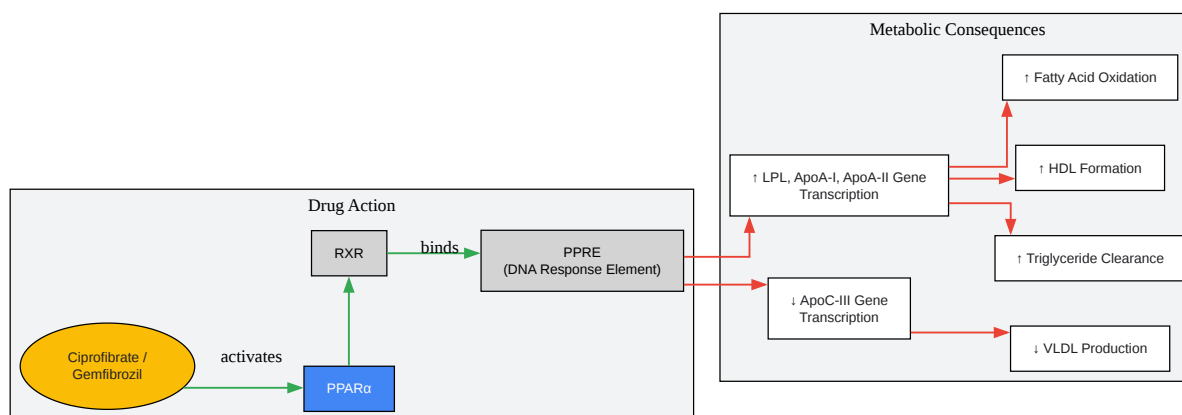

[Click to download full resolution via product page](#)

Caption: Fibrate mechanism of action via PPAR α activation.

A typical preclinical study to compare these compounds follows a standardized workflow to ensure robust and reproducible data.

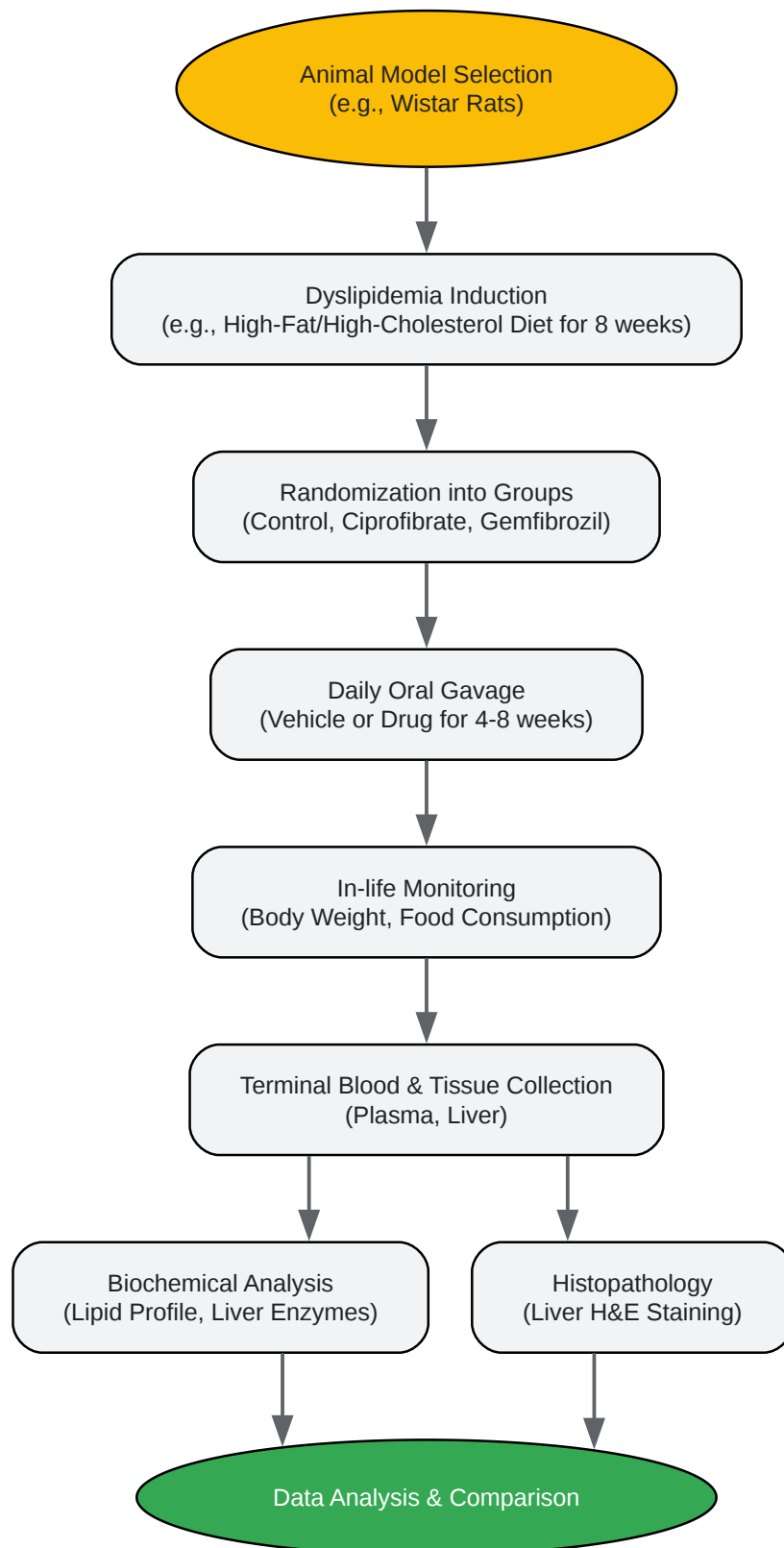

[Click to download full resolution via product page](#)

Caption: Standard preclinical workflow for fibrate comparison.

Experimental Protocols

Detailed methodologies are essential for the interpretation and replication of preclinical findings.

High-Fat Diet (HFD) Induced Dyslipidemia in Rats

- Animal Model: Male Wistar or Sprague-Dawley rats (150-200g) are commonly used.[4][13]
- Acclimatization: Animals are housed in standard conditions (12h light/dark cycle, controlled temperature and humidity) for at least one week before the experiment.
- Induction of Dyslipidemia: Rats are fed a high-fat diet for a period of 4 to 8 weeks.[5][7] A typical HFD consists of standard chow supplemented with cholesterol (1-2%), cholic acid (0.5%), and fat (e.g., lard or ghee, 10-20%).[7]
- Grouping and Treatment: After the induction period, baseline blood samples are collected. Animals are then randomized into control and treatment groups. Drugs (**ciprofibrate** or gemfibrozil) or vehicle (e.g., 0.5% carboxymethyl cellulose) are administered daily via oral gavage for an additional 4 to 8 weeks.
- Sample Collection: At the end of the treatment period, animals are fasted overnight. Blood is collected via cardiac puncture under anesthesia for serum/plasma separation. The liver is excised, weighed, and sections are preserved in formalin for histology and flash-frozen for biochemical analysis.
- Biochemical Analysis: Plasma samples are analyzed for total cholesterol, triglycerides, HDL-C, and LDL-C using commercially available enzymatic kits. Liver enzymes such as Alanine Aminotransferase (ALT) and Aspartate Aminotransferase (AST) are measured as markers of hepatotoxicity.

Triton WR-1339 Induced Hyperlipidemia Model

- Animal Model: Male Wistar rats (180-220g).
- Principle: Triton WR-1339 is a non-ionic surfactant that suppresses the activity of lipoprotein lipase, leading to an acute and significant increase in plasma triglycerides and cholesterol.[7]

- Procedure:
 - Animals are fasted for 18 hours prior to the experiment.
 - A single intraperitoneal (i.p.) injection of Triton WR-1339 (typically 200-400 mg/kg) dissolved in saline is administered.
 - The test compounds (**ciprofibrate** or gemfibrozil) are administered orally 1 hour before the Triton injection.
 - Blood samples are collected at baseline (pre-Triton) and at various time points post-injection (e.g., 6, 18, and 24 hours).
- Analysis: Plasma triglyceride and total cholesterol levels are measured to determine the ability of the test compounds to prevent or attenuate the Triton-induced hyperlipidemia.

Need Custom Synthesis?

BenchChem offers custom synthesis for rare earth carbides and specific isotopic labeling.

Email: info@benchchem.com or [Request Quote Online](#).

References

1. ema.europa.eu [ema.europa.eu]
2. Effects of the PPAR α Agonist and Widely Used Antihyperlipidemic Drug Gemfibrozil on Hepatic Toxicity and Lipid Metabolism - PMC [pmc.ncbi.nlm.nih.gov]
3. selleckchem.com [selleckchem.com]
4. Modelling hypercholesterolaemia in rats using high cholesterol diet - PMC [pmc.ncbi.nlm.nih.gov]
5. Development of an experimental diet model in rats to study hyperlipidemia and insulin resistance, markers for coronary heart disease - PMC [pmc.ncbi.nlm.nih.gov]
6. ijper.org [ijper.org]
7. globalresearchonline.net [globalresearchonline.net]
8. Gemfibrozil as a lipid lowering compound in hyperlipoproteinaemia. A placebo-controlled cross-over trial - PubMed [pubmed.ncbi.nlm.nih.gov]

- 9. Effects of ciprofibrate on LDL metabolism in man - PubMed [pubmed.ncbi.nlm.nih.gov]
- 10. Ciprofibrate in the therapy of type II hypercholesterolemia. A double-blind trial - PubMed [pubmed.ncbi.nlm.nih.gov]
- 11. The hypolipidemic effects of gemfibrozil in type V hyperlipidemia. A double-blind, crossover study - PubMed [pubmed.ncbi.nlm.nih.gov]
- 12. Gemfibrozil - Some Pharmaceutical Drugs - NCBI Bookshelf [ncbi.nlm.nih.gov]
- 13. researchgate.net [researchgate.net]
- To cite this document: BenchChem. [Ciprofibrate vs. gemfibrozil: efficacy and safety in preclinical models]. BenchChem, [2025]. [Online PDF]. Available at: [https://www.benchchem.com/product/b1669075#ciprofibrate-vs-gemfibrozil-efficacy-and-safety-in-preclinical-models]

Disclaimer & Data Validity:

The information provided in this document is for Research Use Only (RUO) and is strictly not intended for diagnostic or therapeutic procedures. While BenchChem strives to provide accurate protocols, we make no warranties, express or implied, regarding the fitness of this product for every specific experimental setup.

Technical Support: The protocols provided are for reference purposes. Unsure if this reagent suits your experiment? [[Contact our Ph.D. Support Team for a compatibility check](#)]

Need Industrial/Bulk Grade? [Request Custom Synthesis Quote](#)

BenchChem

Our mission is to be the trusted global source of essential and advanced chemicals, empowering scientists and researchers to drive progress in science and industry.

Contact

Address: 3281 E Guasti Rd
Ontario, CA 91761, United States
Phone: (601) 213-4426
Email: info@benchchem.com