

Chemical structure and properties of Ganoderenic acid C

Author: BenchChem Technical Support Team. **Date:** December 2025

Compound of Interest

Compound Name: Ganoderenic acid C

Cat. No.: B1139599

[Get Quote](#)

Ganoderenic Acid C: A Comprehensive Technical Guide

For Researchers, Scientists, and Drug Development Professionals

Abstract

Ganoderenic acid C, a lanostane-type triterpenoid isolated from the medicinal mushroom *Ganoderma lucidum*, is a molecule of significant interest in the pharmaceutical and scientific communities. This technical guide provides a detailed overview of the chemical structure, physicochemical properties, and biological activities of **ganoderenic acid C**. It includes a compilation of quantitative data, comprehensive experimental protocols for its isolation and analysis, and visualizations of its interactions with key cellular signaling pathways. This document is intended to serve as a foundational resource for researchers exploring the therapeutic potential of this promising natural compound.

Chemical Structure and Physicochemical Properties

Ganoderenic acid C is a highly oxygenated tetracyclic triterpenoid. Its structure was first elucidated in 1985 and is characterized by a lanostane core with hydroxyl, ketone, and carboxylic acid functional groups.[1]

IUPAC Name: (20E)-3 β ,7 β ,15 α -trihydroxy-11,23-dioxo-lanosta-8,20(22)-dien-26-oic acid[1]

Table 1: Physicochemical Properties of **Ganoderenic Acid C**

Property	Value	Reference(s)
Molecular Formula	C ₃₀ H ₄₂ O ₇	[1]
Molecular Weight	514.65 g/mol	[1]
CAS Number	100665-42-7	[1]
Appearance	Solid	[2]
Solubility	Soluble in methanol	[2]
Storage	Store at -20°C for long-term stability (≥ 4 years)	[2]

Table 2: Spectroscopic Data for **Ganoderenic Acid C**

Spectroscopic Technique	Key Observations	Reference(s)
Infrared (IR)	Reveals the presence of hydroxyl, ketone, and carboxylic acid functional groups. The region between 1500 cm ⁻¹ and 1800 cm ⁻¹ is particularly useful for distinguishing different ganoderic acids due to characteristic carbonyl absorptions.	[1]
Mass Spectrometry (MS)	Provides information on the molecular weight and fragmentation pattern. Common fragmentation pathways include the neutral loss of water (H ₂ O) and carbon dioxide (CO ₂).	[1][3]
Nuclear Magnetic Resonance (NMR)	¹ H and ¹³ C NMR are used to elucidate the complex tetracyclic triterpene core and the positions of various functional groups.	[2]

Biological Activities and Quantitative Data

Ganoderenic acid C and its close analogs have demonstrated a range of biological activities, including anti-inflammatory, cytotoxic, and hepatoprotective effects.

Table 3: In Vitro Cytotoxicity of **Ganoderenic Acid C** and Related Compounds

Compound	Cell Line	Cancer Type	IC50 Value	Reference(s)
Ganoderenic acid C	H460	Non-Small Cell Lung Cancer	93 μ M	[4][5]
Ganoderic Acid A	HepG2	Hepatocellular Carcinoma	187.6 μ M (at 24h)	[5]
Ganoderic Acid A	SMMC7721	Hepatocellular Carcinoma	158.9 μ M (at 24h)	[5]
Ganoderic Acid T	HeLa	Cervical Cancer	27.9 μ g/mL	[6]
Ganoderic Acid DM	MDA-MB-231	Breast Cancer	~20-40 μ M	[6]
Ganoderic Acid DM	PC-3	Prostate Cancer	~25-50 μ M	[6]

 Table 4: Anti-inflammatory Activity of **Ganoderenic Acid C** and Related Compounds

Compound	Assay System	Inhibited Mediator	IC50 Value	Reference(s)
Ganoderenic Acid C1	LPS-stimulated RAW 264.7 macrophages	TNF- α	24.5 μ g/mL	[7]
A related ganoderic acid	HMG-CoA Reductase Enzyme Assay	-	22.3 μ M	[8]
A related ganoderic acid	Acyl CoA-cholesterol Acyltransferase Enzyme Assay	-	5.5 μ M	[8]

Experimental Protocols

The following sections detail generalized methodologies for the extraction, purification, and analysis of **ganoderenic acid C** from *Ganoderma lucidum*.

Extraction and Purification of Ganoderenic Acid C

The isolation of **ganoderenic acid C** is a multi-step process involving extraction and several chromatographic purification stages.[\[9\]](#)[\[10\]](#)

Protocol 3.1.1: Crude Extraction

- Preparation of Material: Dry the fruiting bodies of *Ganoderma lucidum* and grind them into a fine powder (40-60 mesh) to increase the surface area for extraction.[\[10\]](#)
- Solvent Extraction: Macerate 1 kg of the powdered mushroom with 10 L of 95% ethanol at room temperature for 24 hours with occasional stirring.[\[10\]](#)
- Filtration: Filter the mixture through cheesecloth followed by Whatman No. 1 filter paper.[\[10\]](#)
- Repeat Extraction: Repeat the extraction process on the residue two more times with fresh 95% ethanol.[\[10\]](#)
- Concentration: Combine all ethanolic extracts and concentrate under reduced pressure using a rotary evaporator at a temperature not exceeding 50°C to obtain the crude extract.[\[10\]](#)

Protocol 3.1.2: Solvent Partitioning

- Resuspension: Resuspend the crude extract in water.
- Liquid-Liquid Extraction: Perform a liquid-liquid extraction with an equal volume of methylene chloride three times. The triterpenoids will partition into the methylene chloride layer.[\[9\]](#)
- Drying and Concentration: Combine the methylene chloride fractions, dry over anhydrous sodium sulfate, and evaporate the solvent under reduced pressure to yield a triterpenoid-enriched fraction.[\[9\]](#)

Protocol 3.1.3: Chromatographic Purification

- Silica Gel Column Chromatography:
 - Prepare a silica gel (200-300 mesh) column packed in chloroform.[9]
 - Dissolve the triterpenoid-enriched fraction in a minimal amount of chloroform and load it onto the column.[9]
 - Elute the column with a gradient of chloroform and methanol, gradually increasing the polarity.[9]
 - Collect fractions and monitor by Thin Layer Chromatography (TLC) or analytical High-Performance Liquid Chromatography (HPLC).[9]
 - Combine the fractions containing **ganoderenic acid C**. [9]
- Reversed-Phase C18 Column Chromatography:
 - Pack a C18 reversed-phase column with a suitable solvent system (e.g., methanol:water). [9]
 - Dissolve the semi-purified fraction in a minimal amount of the mobile phase and load it onto the column.[9]
 - Elute the column with a gradient of methanol and water, starting from 50% methanol and gradually increasing to 100% methanol.[9]
 - Collect and combine the fractions containing the target compound based on analytical HPLC monitoring.[9]
- Preparative HPLC:
 - For high-purity isolation, employ a preparative HPLC system with a C18 column.[9]
 - Use a mobile phase consisting of a gradient of acetonitrile and 0.1% aqueous acetic acid. [9]
 - Set the detection wavelength at 252 nm.[9]

- Collect the peak corresponding to **ganoderenic acid C**.[\[9\]](#)

Protocol 3.1.4: Crystallization

- Evaporate the solvent from the collected HPLC fraction.[\[9\]](#)
- Dissolve the residue in a minimal amount of hot methanol.[\[9\]](#)
- Allow the solution to cool slowly to room temperature, then at 4°C to promote crystallization.
[\[9\]](#)
- Collect the crystals by filtration, wash with a small amount of cold methanol, and dry under vacuum.[\[9\]](#)

Analytical High-Performance Liquid Chromatography (HPLC)

Analytical HPLC is used for the purity assessment and quantification of **ganoderenic acid C**.
[\[2\]](#)

Instrumentation and Conditions (Example):

- Column: Reversed-phase C18 column (e.g., 4.6 x 250 mm)[\[2\]](#)
- Mobile Phase: A gradient of acetonitrile and 0.1% aqueous acetic acid.[\[2\]](#)
- Flow Rate: Approximately 1.0 mL/min.[\[2\]](#)
- Detection: UV detector set at 252 nm.[\[2\]](#)
- Standard: A pure standard of **ganoderenic acid C** is used for identification and quantification.[\[2\]](#)

In Vitro Cytotoxicity Assay (WST-1 Assay)

This protocol details the methodology to determine the half-maximal inhibitory concentration (IC50) of **ganoderenic acid C** on a cancer cell line.[\[5\]](#)

- Cell Seeding:
 - Culture cancer cells (e.g., H460) in T-75 flasks until they reach 80-90% confluency.[5]
 - Trypsinize, count, and resuspend the cells to a concentration of 5×10^4 cells/mL.[5]
 - Seed 100 μ L of the cell suspension (5,000 cells/well) into each well of a 96-well plate and incubate for 24 hours.[5]
- Compound Treatment:
 - Prepare a serial dilution of **ganoderenic acid C** in the culture medium.[5]
 - Remove the medium from the wells and add 100 μ L of the prepared dilutions. Use a vehicle control with the same final DMSO concentration (less than 0.5%).[5]
 - Incubate the plate for 48-72 hours.[5]
- WST-1 Assay:
 - Add 10 μ L of WST-1 reagent to each well and incubate for an additional 1-4 hours at 37°C. [5]
 - Gently shake the plate for 1 minute.[5]
- Data Acquisition and Analysis:
 - Measure the absorbance at 450 nm using a microplate reader.[5]
 - Calculate the percentage of cell viability relative to the vehicle control.
 - Plot the percent viability against the log of the compound concentration and determine the IC50 value using non-linear regression analysis.[5]

Signaling Pathways and Mechanisms of Action

Ganoderenic acid C and its analogs exert their biological effects by modulating several key cellular signaling pathways.

Inhibition of NF- κ B Signaling Pathway

Ganoderic acids have been shown to inhibit the NF- κ B signaling pathway, a central regulator of inflammation and cell survival. The mechanism involves preventing the degradation of I κ B α , which sequesters NF- κ B in the cytoplasm. This blocks the nuclear translocation of the p65 subunit of NF- κ B, thereby inhibiting the transcription of pro-inflammatory and pro-survival genes.[2]

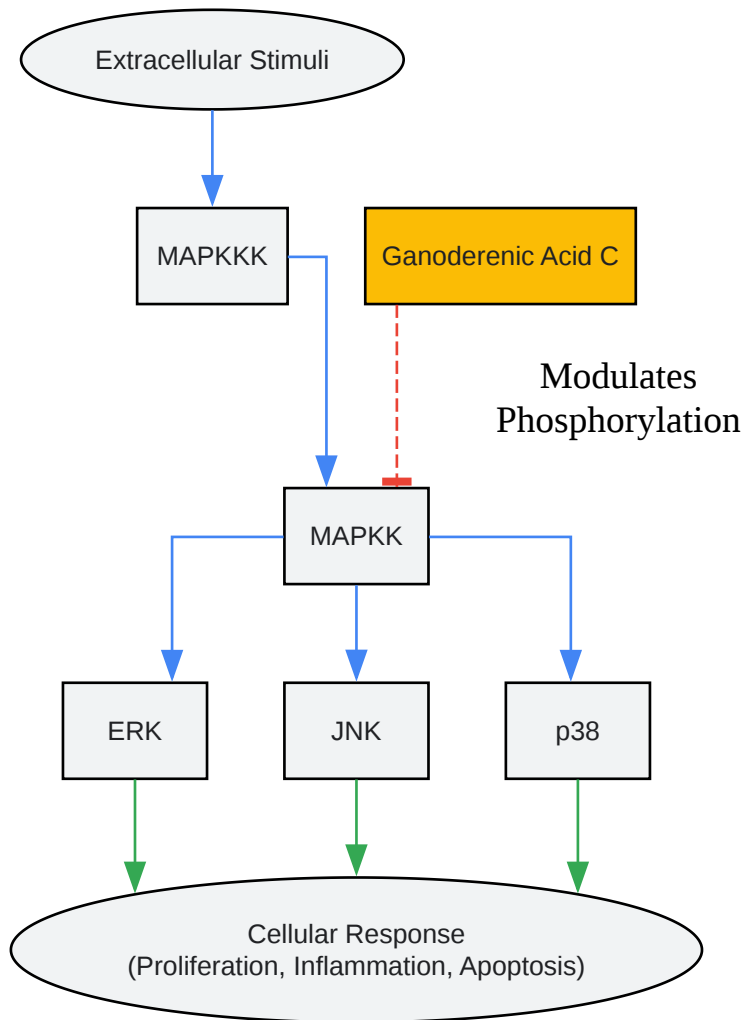
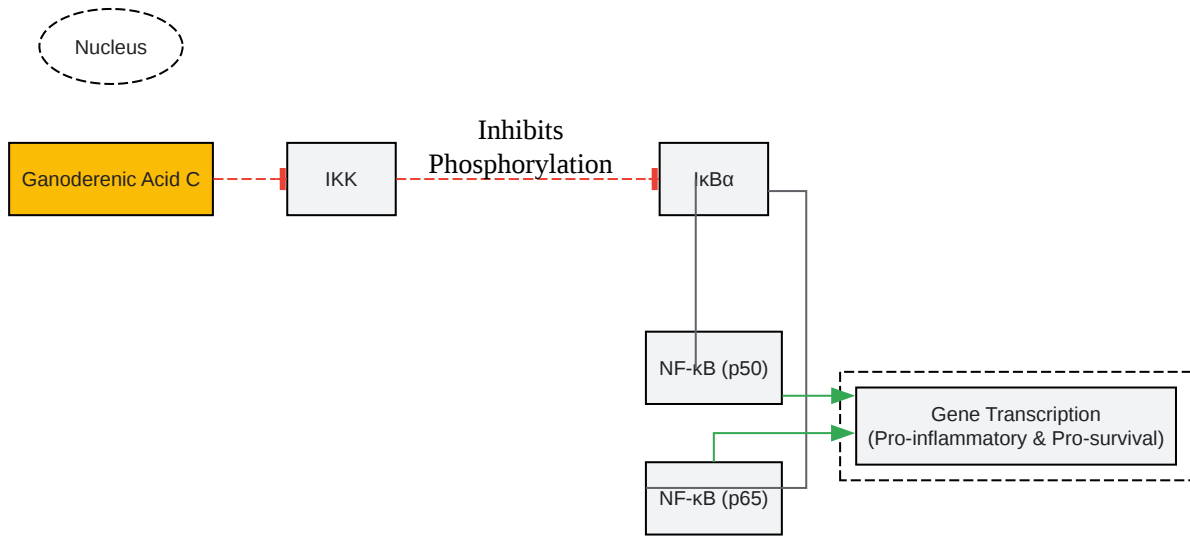

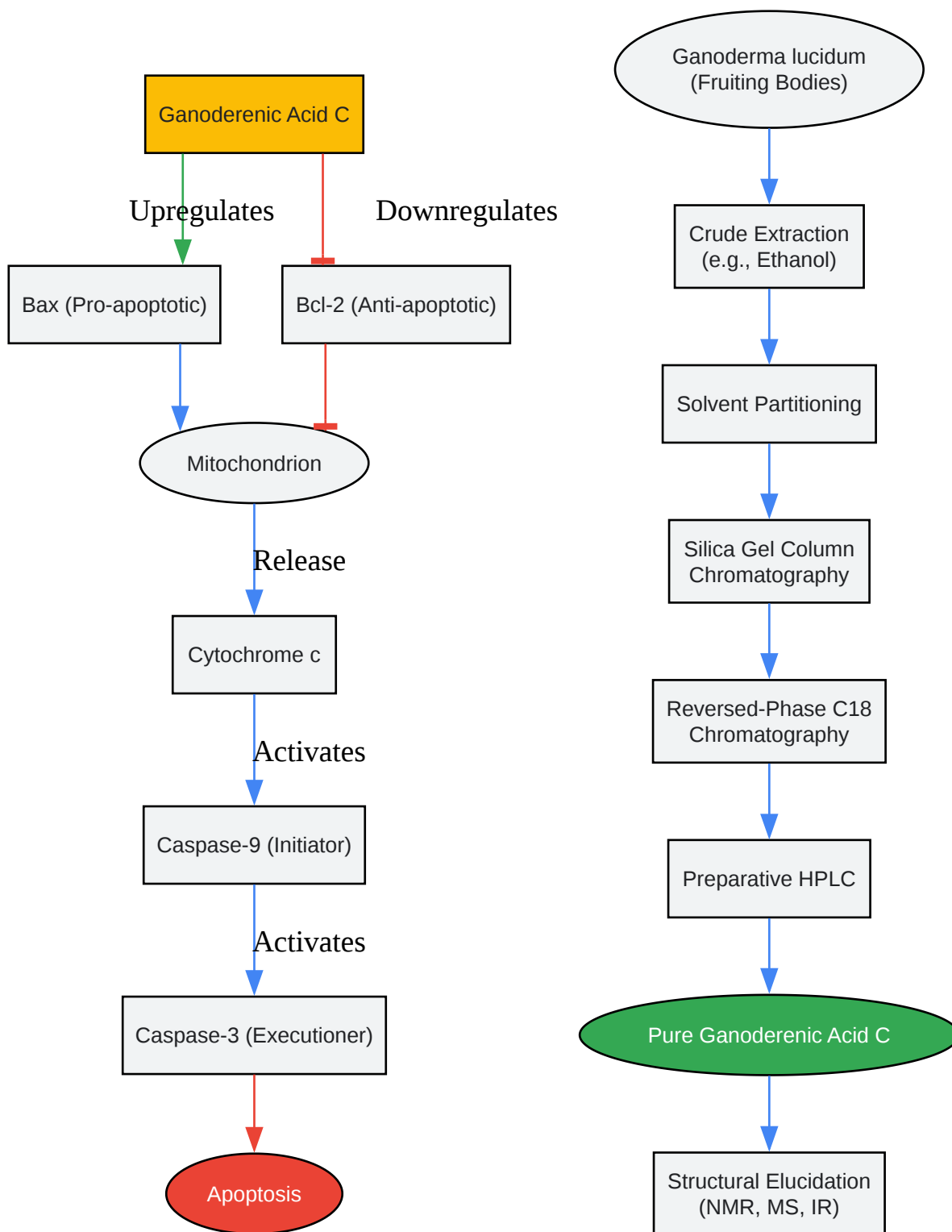

[Click to download full resolution via product page](#)

Need Custom Synthesis?

BenchChem offers custom synthesis for rare earth carbides and specific isotopic labeling.

Email: info@benchchem.com or [Request Quote Online](#).

References

- 1. benchchem.com [benchchem.com]
- 2. benchchem.com [benchchem.com]
- 3. scispace.com [scispace.com]
- 4. Ganoderic acid D prevents oxidative stress-induced senescence by targeting 14-3-3ε to activate CaM/CaMKII/NRF2 signaling pathway in mesenchymal stem cells - PubMed [pubmed.ncbi.nlm.nih.gov]
- 5. Ganoderic acid A: an in-depth review of pharmacological effects and molecular docking analysis - PubMed [pubmed.ncbi.nlm.nih.gov]
- 6. Ganoderic acid D prevents oxidative stress-induced senescence by targeting 14-3-3ε to activate CaM/CaMKII/NRF2 signaling pathway in mesenchymal stem cells - PMC [pmc.ncbi.nlm.nih.gov]
- 7. Inhibition of the JAK-STAT3 signaling pathway by ganoderic acid A enhances chemosensitivity of HepG2 cells to cisplatin - PubMed [pubmed.ncbi.nlm.nih.gov]
- 8. Research Progress on the Biological Activity of Ganoderic Acids in Ganoderma lucidum over the Last Five Years [mdpi.com]
- 9. Apoptotic and Immune Restoration Effects of Ganoderic Acids Define a New Prospective for Complementary Treatment of Cancer - PMC [pmc.ncbi.nlm.nih.gov]
- 10. Ganoderic acid hinders renal fibrosis via suppressing the TGF-β/Smad and MAPK signaling pathways - PMC [pmc.ncbi.nlm.nih.gov]
- To cite this document: BenchChem. [Chemical structure and properties of Ganoderenic acid C]. BenchChem, [2025]. [Online PDF]. Available at: [https://www.benchchem.com/product/b1139599#chemical-structure-and-properties-of-ganoderenic-acid-c]

Disclaimer & Data Validity:

The information provided in this document is for Research Use Only (RUO) and is strictly not intended for diagnostic or therapeutic procedures. While BenchChem strives to provide accurate protocols, we make no warranties, express or implied, regarding the fitness of this product for every specific experimental setup.

Technical Support: The protocols provided are for reference purposes. Unsure if this reagent suits your experiment? [[Contact our Ph.D. Support Team for a compatibility check](#)]

Need Industrial/Bulk Grade? [Request Custom Synthesis Quote](#)

BenchChem

Our mission is to be the trusted global source of essential and advanced chemicals, empowering scientists and researchers to drive progress in science and industry.

Contact

Address: 3281 E Guasti Rd
Ontario, CA 91761, United States
Phone: (601) 213-4426
Email: info@benchchem.com