

Benchmarking E3 Ligase Ligand 23 Against Novel CRBN Binders: A Comparative Guide

Author: BenchChem Technical Support Team. **Date:** December 2025

Compound of Interest

Compound Name: E3 ligase Ligand 23

Cat. No.: B8759177

[Get Quote](#)

For Researchers, Scientists, and Drug Development Professionals

In the rapidly advancing field of targeted protein degradation (TPD), the selection of an optimal E3 ubiquitin ligase ligand is a critical determinant of the success of a proteolysis-targeting chimera (PROTAC). Cereblon (CRBN), a substrate receptor of the CUL4-DDB1 E3 ubiquitin ligase complex, remains a widely exploited target for PROTAC development. This guide provides a comparative analysis of "E3 Ligase Ligand-Linker Conjugate 23 (TFA)," a representative of thalidomide-based ligands with an ether linkage, against emerging novel CRBN binders. This comparison focuses on key performance metrics, experimental validation, and the underlying biological pathways.

While direct comparative experimental data for "E3 Ligase Ligand-Linker Conjugate 23 (TFA)" is not publicly available, this guide will infer its potential characteristics based on its structural features and benchmark it against well-characterized novel CRBN binders. The aim is to provide a framework for researchers to evaluate and select the most appropriate CRBN ligand for their TPD projects.

Executive Summary

Traditional CRBN ligands, derived from immunomodulatory imide drugs (IMiDs) like thalidomide, pomalidomide, and lenalidomide, have been instrumental in the development of numerous PROTACs. However, their application is often hampered by challenges such as chemical instability and off-target effects arising from the degradation of endogenous CRBN neosubstrates (e.g., IKZF1, GSPT1). "E3 Ligase Ligand-Linker Conjugate 23 (TFA)" represents

a modification of the classic thalidomide scaffold, incorporating a polyethylene glycol (PEG) linker via an ether bond. This modification may offer altered physicochemical properties.

In response to the limitations of IMiDs, a new generation of CRBN binders has emerged. These novel ligands, including phenyl-glutarimides, benzamides, and cyclimids, are designed to offer improved stability, enhanced selectivity, and a differentiated neosubstrate degradation profile. This guide will delve into a comparative analysis of these different classes of CRBN binders.

Data Presentation: A Comparative Overview of CRBN Ligands

The following tables summarize key performance indicators for different classes of CRBN ligands. It is important to note that the data for "**E3 Ligase Ligand 23 (TFA)**" is inferred based on its structural similarity to other thalidomide-ether linked compounds, and direct experimental validation is required for confirmation.

Table 1: Quantitative Comparison of CRBN Ligand Performance

Ligand Class	Representative Structure	CRBN Binding Affinity (IC ₅₀ /K _d)	Target Degradation (PROTAC DC ₅₀)	Neosubstrate Degradation (IKZF1/GSPT1)	Chemical Stability	Key Advantages	Key Disadvantages
Thalimide-Ether Linker (e.g., E3 Ligase Ligand 23)	Thalimide core with ether-linked PEG chain	Likely in the μM range (inferred)	Dependent on target and linker	Potential for neosubstrate degradation	Moderate	Well-established chemistry	Potential instability, neosubstrate effects
Phenyl-Glutarimides	Phenyl ring replacing phthalimide	μM to nM range[1]	Can achieve pM to nM potency[1][2]	Reduced neosubstrate degradation reported	Improved hydrolytic stability[1]	High potency, improved stability	Newer scaffold, less explored
Benzamides	Non-phthalimide, mimics natural degron interactions	μM to nM range[3]	Potent degradation demonstrated	Favorable selectivity profile	Improved chemical stability	Reduced neosubstrate effects, stable	Newer scaffold, requires optimization
Cyclimids	Inspired by C-terminal cyclic imide degrons	nM to μM range	Potent and selective degradation	Can minimize off-target degradation	Stable	Distinct ternary complex formation	Newer class, structure-activity relationship still under

investigat
 ion

Table 2: Representative PROTAC Performance with Different CRBN Ligands

PROTAC	CRBN Ligand Class	Target Protein	DC50	Dmax	Cell Line	Reference
Hypothetical PROTAC with Ligand 23	Thalidomide-Ether Linker	-	Not Available	Not Available	-	-
PG PROTAC 4c	Phenyl-Glutarimide	BRD4	0.87 nM	>99%	MV4-11	
PD-PROTAC 5	Phenyl Dihydrouracil	LCK	0.23 nM	>98%	KOPT-K1	
dBET6	Thalidomide-based	BRD4	<100 nM	>90%	-	

Experimental Protocols

Accurate benchmarking of E3 ligase ligands requires robust and standardized experimental protocols. Below are methodologies for key experiments to evaluate the performance of CRBN binders.

CRBN Binding Affinity Assay (Fluorescence Polarization - FP)

This assay measures the binding affinity of a ligand to CRBN in a competitive format.

- Principle: A fluorescently labeled CRBN ligand (tracer) is displaced by a test compound, leading to a decrease in fluorescence polarization.
- Materials:
 - Purified recombinant CRBN protein (or CRBN-DDB1 complex).
 - Fluorescently labeled CRBN binder (e.g., FITC-thalidomide or a commercial Cy5-labeled thalidomide).
 - Test compounds (**E3 ligase ligand 23** and novel binders).
 - Assay buffer (e.g., 50 mM HEPES pH 7.5, 100 mM NaCl, 1 mM DTT, 0.01% BSA, 0.01% Tween-20).
 - Black, low-volume 384-well plates.
- Procedure:
 - Prepare serial dilutions of the test compounds in assay buffer.
 - In the microplate, add the CRBN protein and the fluorescent tracer at a fixed concentration.
 - Add the serially diluted test compounds or vehicle control.
 - Incubate the plate at room temperature for 60 minutes to reach binding equilibrium.
 - Measure the fluorescence polarization using a suitable plate reader.
- Data Analysis:
 - Plot the fluorescence polarization values against the logarithm of the test compound concentration.
 - Fit the data to a sigmoidal dose-response curve to determine the IC50 value.
 - Calculate the binding affinity (K_i) using the Cheng-Prusoff equation.

Cellular Protein Degradation Assay (Western Blot)

This assay quantifies the degradation of a target protein and neosubstrates in cells treated with a PROTAC.

- Principle: The levels of the target protein and neosubstrates are measured by immunoblotting after treating cells with a PROTAC incorporating the E3 ligase ligand of interest.
- Materials:
 - Cell line expressing the target protein and CRBN.
 - PROTACs synthesized with the respective CRBN ligands.
 - Cell lysis buffer (e.g., RIPA buffer with protease and phosphatase inhibitors).
 - Primary antibodies against the target protein, IKZF1, GSPT1, and a loading control (e.g., GAPDH, β -actin).
 - HRP-conjugated secondary antibodies.
 - Chemiluminescent substrate.
- Procedure:
 - Seed cells in multi-well plates and allow them to adhere.
 - Treat the cells with a serial dilution of the PROTACs for a specified time (e.g., 24 hours).
 - Lyse the cells and determine the protein concentration of the lysates.
 - Separate the proteins by SDS-PAGE and transfer them to a PVDF membrane.
 - Block the membrane and probe with the primary antibodies.
 - Incubate with the secondary antibodies and detect the signal using a chemiluminescence imaging system.

- Data Analysis:
 - Quantify the band intensities using densitometry software.
 - Normalize the target protein and neosubstrate band intensities to the loading control.
 - Calculate the percentage of protein degradation relative to the vehicle-treated control.
 - Plot the percentage of degradation against the logarithm of the PROTAC concentration to determine the DC50 (concentration for 50% degradation) and Dmax (maximum degradation) values.

Signaling Pathways and Experimental Workflows

Visualizing the underlying biological processes and experimental procedures is crucial for understanding and designing effective protein degraders.

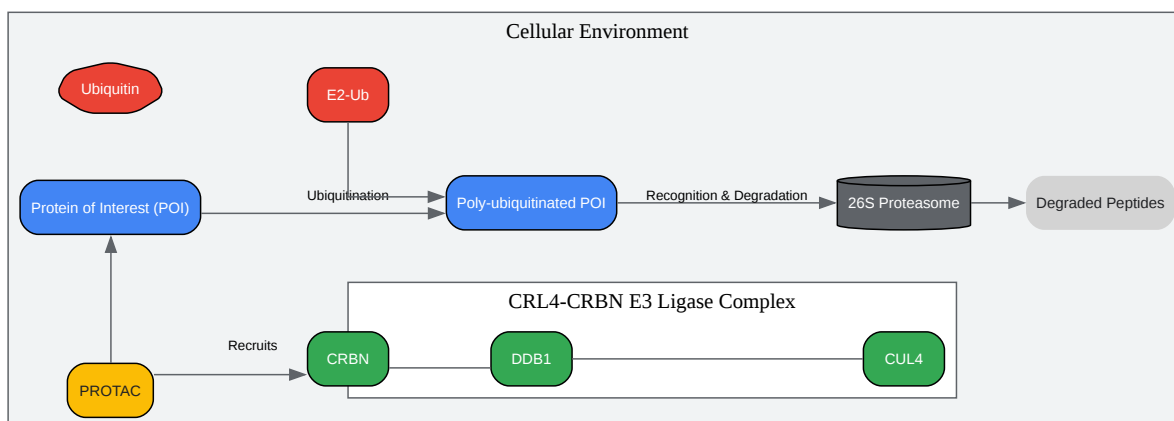

[Click to download full resolution via product page](#)

CRBN-mediated protein degradation pathway.

The diagram above illustrates the mechanism of action of a CRBN-recruiting PROTAC. The PROTAC molecule simultaneously binds to the Protein of Interest (POI) and the CRBN subunit of the CRL4-CRBN E3 ubiquitin ligase complex. This induced proximity facilitates the transfer of ubiquitin from an E2-conjugating enzyme to the POI, leading to its poly-ubiquitination. The poly-ubiquitinated POI is then recognized and degraded by the 26S proteasome.

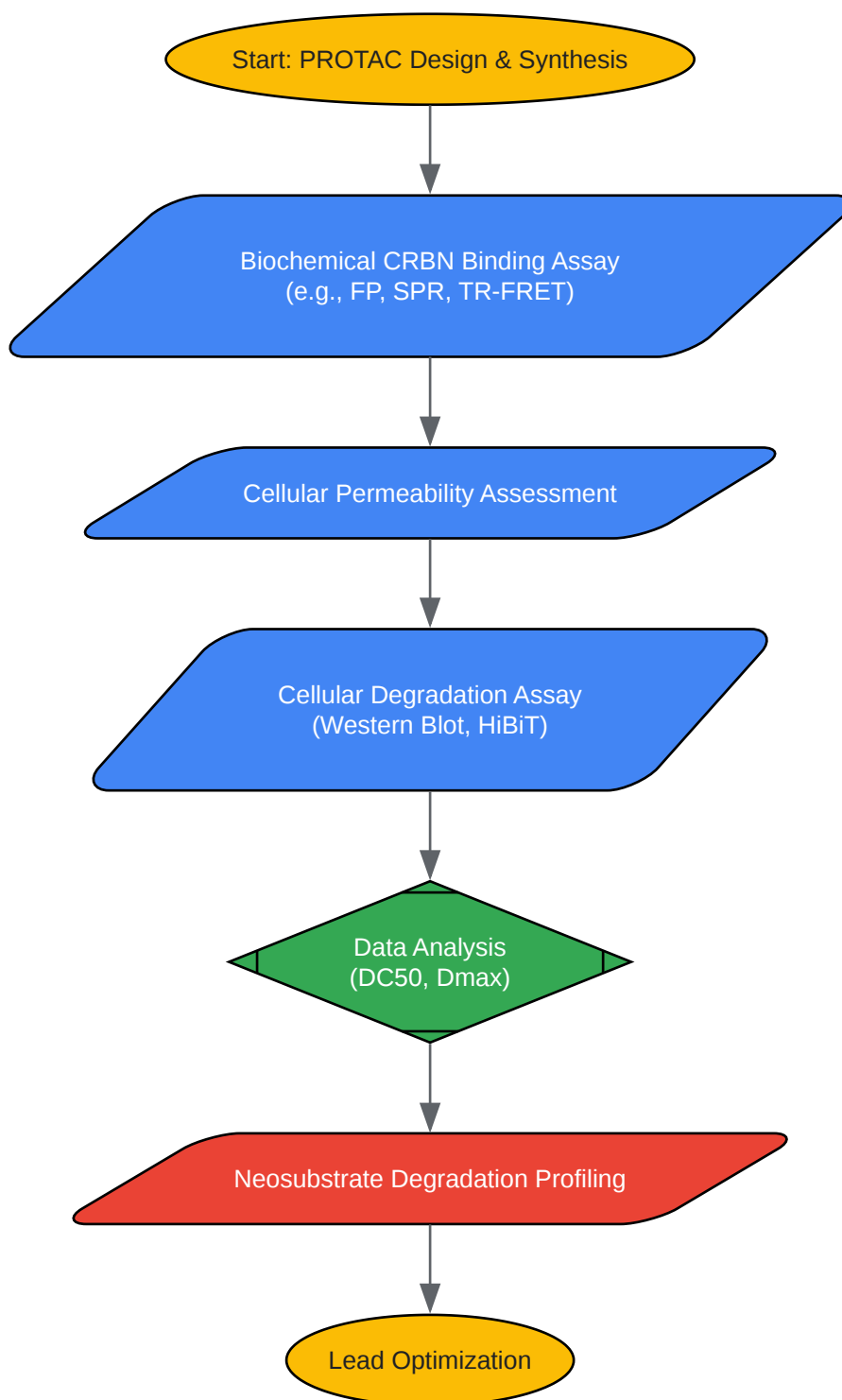

[Click to download full resolution via product page](#)

Experimental workflow for PROTAC evaluation.

The experimental workflow for evaluating a new PROTAC, and by extension its E3 ligase ligand, begins with the design and synthesis of the molecule. The initial biochemical validation of binding to the E3 ligase is a crucial first step. This is followed by assessing the compound's ability to enter cells and induce the degradation of the target protein. Quantitative analysis of degradation provides key performance metrics. Profiling for the degradation of known neosubstrates is essential for assessing off-target effects. The collective data from these assays informs the iterative process of lead optimization.

Conclusion

The landscape of CRBN ligands for targeted protein degradation is rapidly evolving, with novel binders offering promising advantages over traditional IMiD-based scaffolds. While "E3 Ligase Ligand-Linker Conjugate 23 (TFA)" represents a synthetically accessible starting point based on the well-established thalidomide core, its performance in terms of stability and selectivity needs to be experimentally validated against the emerging classes of novel CRBN binders.

Phenyl-glutarimides, benzamides, and cyclimids have demonstrated the potential to deliver highly potent and selective protein degraders with improved physicochemical properties and reduced off-target neosubstrate degradation. Researchers and drug developers are encouraged to consider these novel scaffolds in their PROTAC design strategies. The experimental protocols and workflows outlined in this guide provide a robust framework for the head-to-head comparison of different CRBN ligands, ultimately enabling the selection of the optimal E3 ligase binder to advance the development of next-generation protein degraders.

Need Custom Synthesis?

BenchChem offers custom synthesis for rare earth carbides and specific isotopic labeling.

Email: info@benchchem.com or [Request Quote Online](#).

References

- 1. Phenyl-Glutarimides: Alternative Cereblon Binders for the Design of PROTACs - PMC [pmc.ncbi.nlm.nih.gov]
- 2. researchgate.net [researchgate.net]
- 3. pubs.acs.org [pubs.acs.org]
- To cite this document: BenchChem. [Benchmarking E3 Ligase Ligand 23 Against Novel CRBN Binders: A Comparative Guide]. BenchChem, [2025]. [Online PDF]. Available at: [https://www.benchchem.com/product/b8759177#benchmarking-e3-ligase-ligand-23-against-novel-crbn-binders]

Disclaimer & Data Validity:

The information provided in this document is for Research Use Only (RUO) and is strictly not intended for diagnostic or therapeutic procedures. While BenchChem strives to provide accurate protocols, we make no warranties, express or implied, regarding the fitness of this product for every specific experimental setup.

Technical Support: The protocols provided are for reference purposes. Unsure if this reagent suits your experiment? [[Contact our Ph.D. Support Team for a compatibility check](#)]

Need Industrial/Bulk Grade? [Request Custom Synthesis Quote](#)

BenchChem

Our mission is to be the trusted global source of essential and advanced chemicals, empowering scientists and researchers to drive progress in science and industry.

Contact

Address: 3281 E Guasti Rd
Ontario, CA 91761, United States
Phone: (601) 213-4426
Email: info@benchchem.com