

BMT-108908: A Selective GluN2B Negative Allosteric Modulator

Author: BenchChem Technical Support Team. **Date:** December 2025

Compound of Interest

Compound Name: BMT-108908

Cat. No.: B13434104

[Get Quote](#)

An In-depth Technical Guide for Researchers and Drug Development Professionals

Introduction

The N-methyl-D-aspartate (NMDA) receptor is a critical ionotropic glutamate receptor involved in excitatory synaptic transmission, synaptic plasticity, and memory formation.[1] Composed of various subunits, the NMDA receptor's function is finely tuned by its subunit composition. The GluN2B subunit, in particular, has been a focal point for therapeutic intervention due to its association with various neurological and psychiatric disorders. **BMT-108908** is a potent and selective negative allosteric modulator (NAM) of the GluN2B subunit, demonstrating potential for the treatment of conditions associated with NMDA receptor hyperactivity. This technical guide provides a comprehensive overview of the preclinical data, mechanism of action, and experimental methodologies related to **BMT-108908**.

Core Compound Details

BMT-108908, with the chemical formula C₂₂H₂₅FN₂O₂, is chemically identified as (R)-1-(4-fluorobenzyl)-3-(4-(4-hydroxyphenyl)piperidin-1-yl)pyrrolidin-2-one.[2]

Quantitative Data Summary

The preclinical characterization of **BMT-108908** has established its high affinity and selectivity for the GluN2B subunit of the NMDA receptor. The following tables summarize the key quantitative data from in vitro and in vivo studies.

Table 1: In Vitro Binding Affinity of **BMT-108908**

Target	Species	Radioligand	Ki (nM)
GluN2B	Human	[3H]Ro25-6981	1.6[1]
GluN2B	Cynomolgus Monkey	[3H]Ro25-6981	0.71[1]
GluN2B	Rat	[3H]Ro25-6981	1.4[1]

Table 2: In Vitro Functional Activity of **BMT-108908**

Receptor Subtype	Species	Assay System	IC50 (nM)
hNR1A/2B	Human	Xenopus Oocytes	4.2[1]
hNR1A/2A	Human	Xenopus Oocytes	Inactive[1]
hNR1A/2C	Human	Xenopus Oocytes	Inactive[1]
hNR1A/2D	Human	Xenopus Oocytes	Inactive[1]

Table 3: In Vivo Cognitive Effects of **BMT-108908** in a Delayed Matching-to-Sample (DMS) Task

Dose (mg/kg)	Effect on Task Completion	Average Latency to Respond (ms increase)	Performance Impairment	Average Plasma Concentration (30 min post-dose, nM)
0.3	No impairment	Not specified	Selective impairment in memory at long-delay	279[1]
1.0	No impairment	355[1]	Impairment of list-DMS performance at long-delay	Not specified

Mechanism of Action

BMT-108908 acts as a negative allosteric modulator of NMDA receptors containing the GluN2B subunit. Unlike competitive antagonists that bind to the glutamate or glycine binding sites, or channel blockers that physically obstruct the ion channel, **BMT-108908** binds to a distinct allosteric site on the GluN2B subunit. This binding event induces a conformational change in the receptor, reducing the probability of channel opening in response to agonist binding, thereby decreasing the influx of Ca²⁺ and Na⁺ ions. This modulatory action allows for a more subtle and potentially safer inhibition of NMDA receptor function compared to complete antagonism.

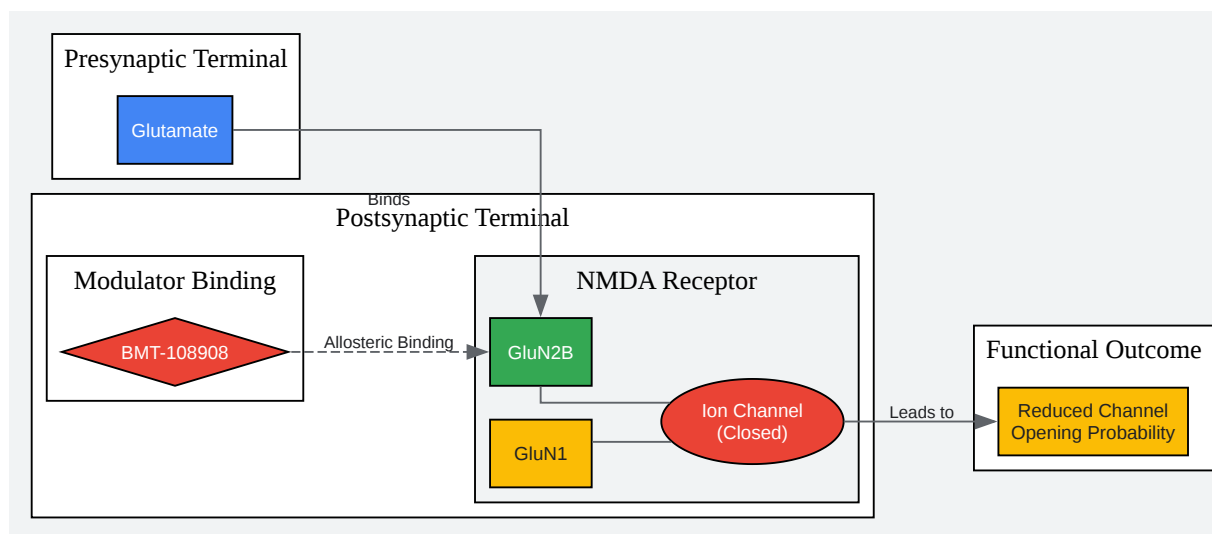

[Click to download full resolution via product page](#)

Caption: Mechanism of action of **BMT-108908** on the GluN2B-containing NMDA receptor.

Experimental Protocols

The following sections describe generalized methodologies representative of the key experiments used to characterize **BMT-108908**.

Radioligand Binding Assay

This assay is employed to determine the binding affinity (K_i) of **BMT-108908** for the GluN2B receptor.

1. Membrane Preparation:

- Brain tissue (e.g., rat cortex) or cells expressing the target receptor are homogenized in a cold lysis buffer.
- The homogenate is centrifuged to pellet the membranes.
- The membrane pellet is washed and resuspended in an appropriate assay buffer.

2. Binding Reaction:

- In a multi-well plate, the membrane preparation is incubated with a specific radioligand for the GluN2B receptor (e.g., [3H]Ro25-6981) and varying concentrations of **BMT-108908**.
- Separate wells are used to determine total binding (radioligand only) and non-specific binding (radioligand in the presence of a high concentration of a non-labeled competitor).

3. Filtration and Detection:

- The reaction is terminated by rapid filtration through a glass fiber filter, which traps the membranes with bound radioligand.
- The filters are washed with ice-cold buffer to remove unbound radioligand.
- The radioactivity retained on the filters is measured using a scintillation counter.

4. Data Analysis:

- Specific binding is calculated by subtracting non-specific binding from total binding.
- The concentration of **BMT-108908** that inhibits 50% of the specific binding (IC50) is determined by non-linear regression analysis.
- The IC50 value is converted to a Ki value using the Cheng-Prusoff equation.

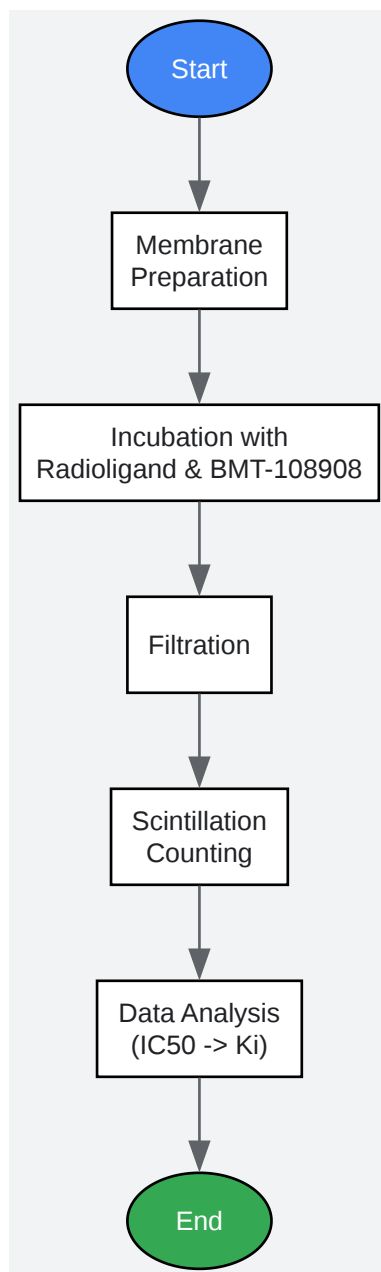

[Click to download full resolution via product page](#)

Caption: Workflow for a typical radioligand binding assay.

Two-Electrode Voltage Clamp (TEVC) in *Xenopus* Oocytes

This electrophysiological technique is used to assess the functional inhibition (IC₅₀) of NMDA receptors by **BMT-108908**.

1. Oocyte Preparation:

- *Xenopus laevis* oocytes are harvested and defolliculated.
- cRNA encoding the desired NMDA receptor subunits (e.g., human GluN1 and GluN2B) is microinjected into the oocytes.
- The oocytes are incubated for several days to allow for receptor expression on the cell membrane.

2. Electrophysiological Recording:

- An oocyte is placed in a recording chamber and perfused with a recording solution.
- Two microelectrodes, one for voltage sensing and one for current injection, are inserted into the oocyte.
- The membrane potential is clamped at a holding potential (e.g., -70 mV).

3. Drug Application and Data Acquisition:

- NMDA receptor-mediated currents are elicited by applying glutamate and glycine to the oocyte.
- After a stable baseline current is established, **BMT-108908** is applied at various concentrations, and the resulting inhibition of the NMDA-evoked current is measured.

4. Data Analysis:

- The percentage of inhibition of the NMDA-evoked current is calculated for each concentration of **BMT-108908**.
- The IC₅₀ value is determined by fitting the concentration-response data to a sigmoidal dose-response curve.

Signaling Pathways

The overactivation of GluN2B-containing NMDA receptors is implicated in excitotoxic cell death pathways. By negatively modulating these receptors, **BMT-108908** can potentially mitigate downstream pathological signaling.

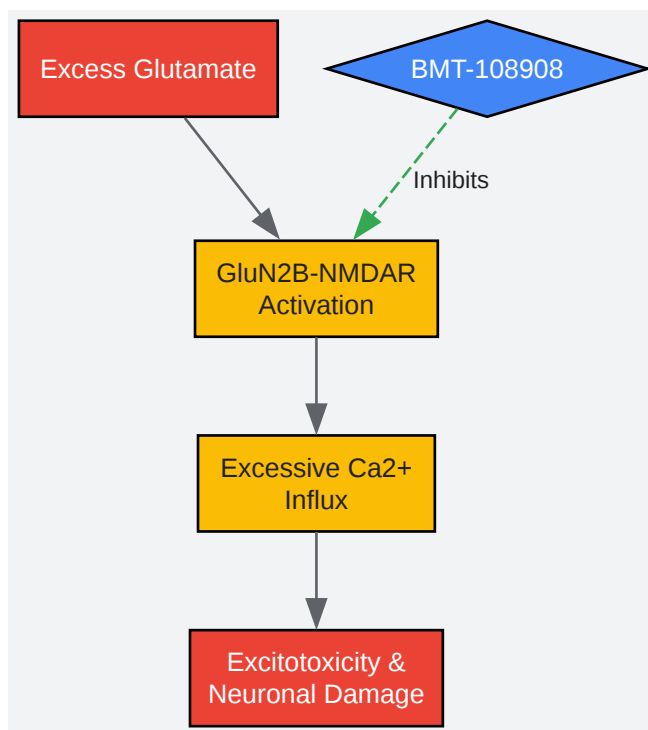

[Click to download full resolution via product page](#)

Caption: Simplified signaling pathway showing the role of **BMT-108908** in mitigating excitotoxicity.

Conclusion

BMT-108908 is a potent and selective GluN2B negative allosteric modulator with a well-defined preclinical profile. Its ability to selectively inhibit GluN2B-containing NMDA receptors suggests therapeutic potential in a range of CNS disorders characterized by NMDA receptor hyperactivity. The data presented in this guide provide a solid foundation for further research and development of this and similar compounds. The detailed experimental methodologies offer a framework for the continued investigation of novel NMDA receptor modulators.

Need Custom Synthesis?

BenchChem offers custom synthesis for rare earth carbides and specific isotopic labeling.

Email: info@benchchem.com or [Request Quote Online](#).

References

- 1. benchchem.com [benchchem.com]
- 2. medkoo.com [medkoo.com]
- To cite this document: BenchChem. [BMT-108908: A Selective GluN2B Negative Allosteric Modulator]. BenchChem, [2025]. [Online PDF]. Available at: [https://www.benchchem.com/product/b13434104#bmt-108908-as-a-gluN2b-negative-allosteric-modulator]

Disclaimer & Data Validity:

The information provided in this document is for Research Use Only (RUO) and is strictly not intended for diagnostic or therapeutic procedures. While BenchChem strives to provide accurate protocols, we make no warranties, express or implied, regarding the fitness of this product for every specific experimental setup.

Technical Support: The protocols provided are for reference purposes. Unsure if this reagent suits your experiment? [[Contact our Ph.D. Support Team for a compatibility check](#)]

Need Industrial/Bulk Grade? [Request Custom Synthesis Quote](#)

BenchChem

Our mission is to be the trusted global source of essential and advanced chemicals, empowering scientists and researchers to drive progress in science and industry.

Contact

Address: 3281 E Guasti Rd

Ontario, CA 91761, United States

Phone: (601) 213-4426

Email: info@benchchem.com