

BACE1-IN-1: A Technical Guide to its Impact on Synaptic Function

Author: BenchChem Technical Support Team. **Date:** December 2025

Compound of Interest

Compound Name: BACE1-IN-1

Cat. No.: B610529

[Get Quote](#)

For Researchers, Scientists, and Drug Development Professionals

Introduction

Beta-site amyloid precursor protein cleaving enzyme 1 (BACE1) is a critical aspartyl protease in the amyloidogenic pathway, responsible for the initial cleavage of the amyloid precursor protein (APP). This cleavage is the rate-limiting step in the production of amyloid-beta (A β) peptides, which are central to the pathophysiology of Alzheimer's disease. Consequently, BACE1 has emerged as a primary therapeutic target for mitigating A β -related synaptic dysfunction.[1] BACE1 inhibitors, such as the representative compound **BACE1-IN-1**, are being extensively investigated for their potential to halt or reverse the progression of Alzheimer's disease.

However, the role of BACE1 extends beyond A β production. The enzyme has several other physiological substrates that are crucial for normal synaptic function, development, and plasticity.[2][3] Therefore, a thorough understanding of the on-target effects of BACE1 inhibition on synaptic integrity and function is paramount for the safe and effective development of BACE1-targeted therapeutics. This technical guide provides an in-depth overview of the impact of BACE1 inhibition, using **BACE1-IN-1** as a representative agent, on synaptic function, supported by quantitative data, detailed experimental protocols, and signaling pathway visualizations.

The Dual Role of BACE1 at the Synapse

BACE1 is localized in both presynaptic and postsynaptic compartments, including axons and dendrites, with notable accumulation in presynaptic terminals.[4][5] Its enzymatic activity at these sites influences synaptic function through two primary mechanisms: the amyloidogenic pathway and the processing of other key synaptic substrates.

Amyloidogenic Pathway and A β -Mediated Synaptic Dysfunction

In the amyloidogenic pathway, BACE1 cleaves APP to generate a soluble N-terminal fragment (sAPP β) and a membrane-bound C-terminal fragment (C99). The subsequent cleavage of C99 by γ -secretase releases A β peptides.[4] Pathological accumulation of A β oligomers is known to impair synaptic function by:

- Inhibiting Long-Term Potentiation (LTP): A β oligomers can interfere with NMDA receptor function and induce the removal of AMPA receptors from the synapse, both of which are critical for the induction and maintenance of LTP, a cellular correlate of learning and memory.
- Enhancing Long-Term Depression (LTD): A β can facilitate LTD, a process that weakens synaptic strength.
- Inducing Synaptic Loss: Chronic exposure to high levels of A β can lead to dendritic spine loss and overall synapse degeneration.

By inhibiting BACE1, compounds like **BACE1-IN-1** reduce the production of A β , thereby mitigating these detrimental effects on synaptic function.

Processing of Non-APP Substrates and Physiological Synaptic Roles

Beyond APP, BACE1 cleaves a variety of other substrates that are integral to synaptic development and plasticity.[2][3] Inhibition of BACE1 can therefore interfere with these physiological processes. Key non-APP substrates include:

- Neuregulin-1 (Nrg1): Involved in regulating myelination, synaptic plasticity, and the expression of glutamate receptors. BACE1-mediated cleavage of Nrg1 is crucial for its signaling through ErbB4 receptors.[1][6]

- Jagged-1 (Jag1): A ligand in the Notch signaling pathway, which is important for neural development, synaptic plasticity, and memory formation. BACE1 cleavage of Jag1 modulates Notch signaling.[2][7][8]
- Seizure protein 6 (Sez6): A protein critical for excitatory synapse development and function. [3]
- Voltage-gated sodium channel β -subunits: BACE1 cleavage of these subunits can influence neuronal excitability.

Inhibition of BACE1 can disrupt the normal processing of these substrates, leading to potential adverse effects on synaptic structure and function.

Quantitative Data on the Impact of BACE1 Inhibition

The following tables summarize quantitative data from various studies on the effects of BACE1 inhibition on synaptic function and protein levels. "**BACE1-IN-1**" is used here as a representative BACE1 inhibitor, and the data are compiled from studies using various potent BACE1 inhibitors.

Table 1: Effects of BACE1 Inhibition on Synaptic Plasticity and Transmission

Parameter	Treatment Group	Result	Reference
Long-Term Potentiation (LTP) in Hippocampal CA1	Wild-type + BACE1 Inhibitor	Significant reduction in LTP magnitude.	[9]
BACE1 Knockout	Abolished LTP.	[10]	
Wild-type + Vehicle	Normal LTP induction.	[9]	
Paired-Pulse Facilitation (PPF) at Mossy Fiber Synapses	BACE1 Knockout	Increased PPF ratio (indicating reduced presynaptic release probability).	[10]
Wild-type	Normal PPF ratio.	[10]	
Spontaneous Excitatory Postsynaptic Currents (sEPSCs) in Pyramidal Neurons	Wild-type + BACE1 Inhibitor	Reduced frequency.	
Wild-type + Vehicle	Normal sEPSC frequency.		
Miniature Excitatory Postsynaptic Currents (mEPSCs) in Pyramidal Neurons	Wild-type + BACE1 Inhibitor	Reduced frequency.	
Wild-type + Vehicle	Normal mEPSC frequency.		

Table 2: Effects of BACE1 Inhibition on Synaptic Protein Levels

Protein	Treatment Group	Result	Reference
mGluR1	BACE1 Knockout	Reduced protein levels.	[11]
PSD-95	BACE1 Knockout	Reduced protein levels.	[11]
Synaptophysin	BACE1 Knockout or BACE1 Inhibitor	Reduced protein levels.	[11]
Neuregulin-1 (Nrg1)	BACE1 Knockout	Elevated levels of uncleaved Nrg1.	[6]
Jagged-1 (Jag1)	BACE1 Knockout	Elevated levels of uncleaved Jag1.	[8]

Signaling Pathways Affected by BACE1-IN-1

The following diagrams, generated using the DOT language for Graphviz, illustrate the key signaling pathways influenced by BACE1 activity.

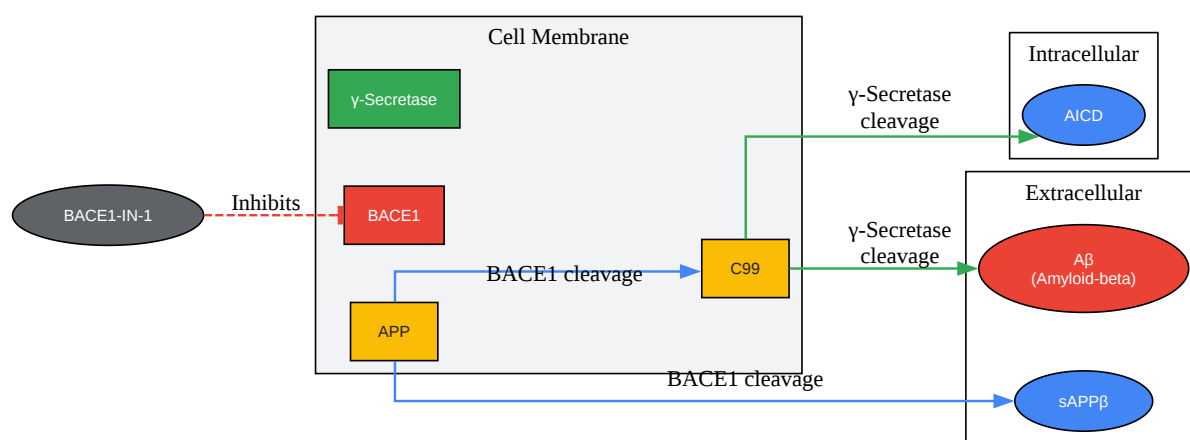

[Click to download full resolution via product page](#)

BACE1 in the Amyloidogenic Pathway and the action of **BACE1-IN-1**.

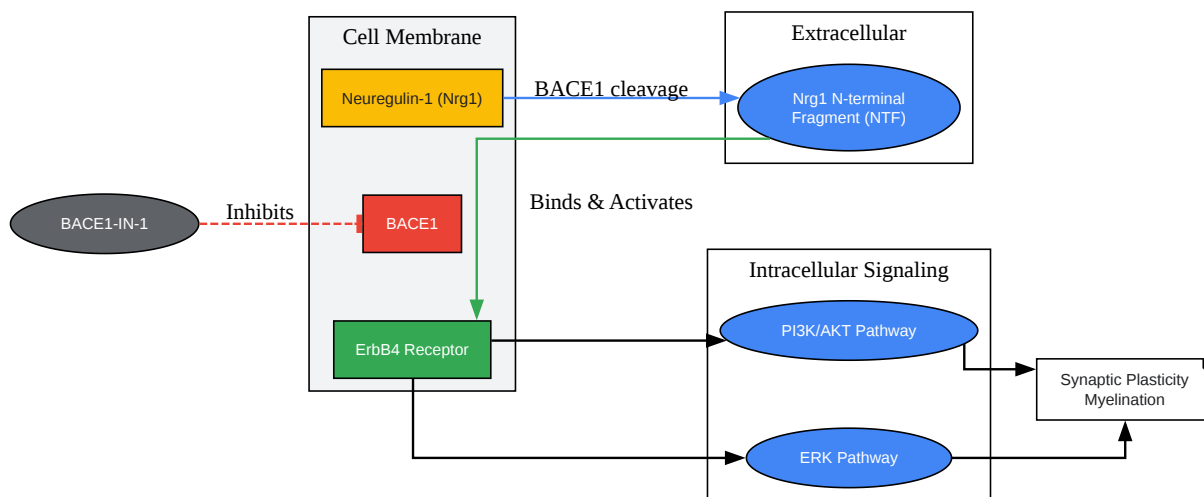

[Click to download full resolution via product page](#)

BACE1-dependent Neuregulin-1 (Nrg1) signaling pathway.

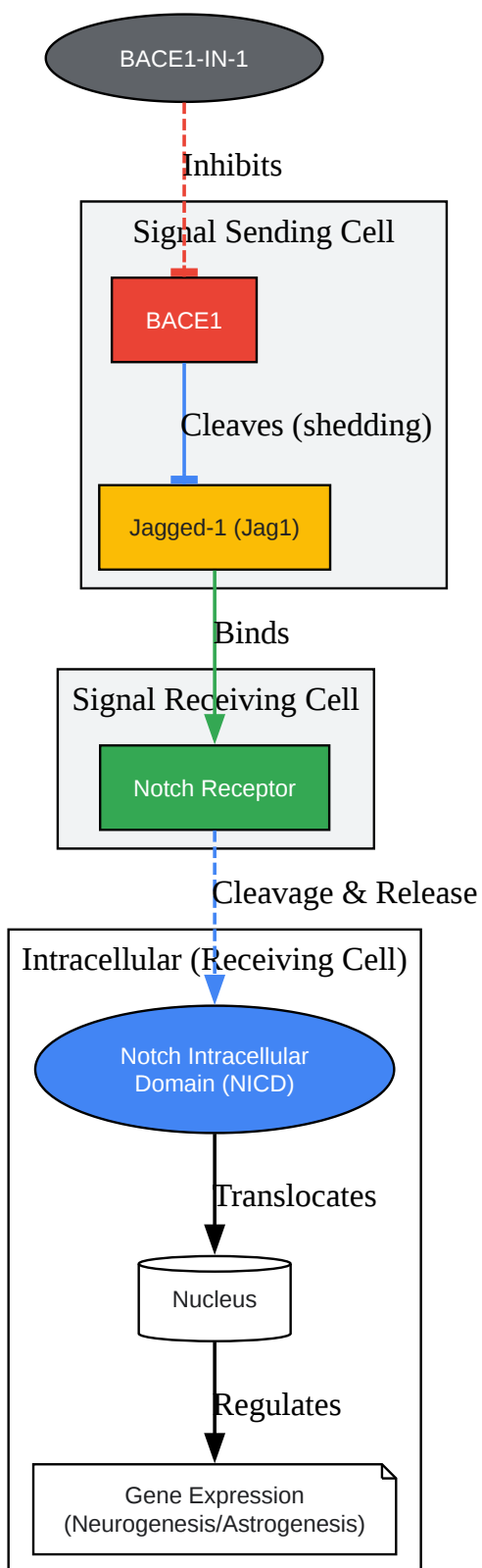

[Click to download full resolution via product page](#)

BACE1 modulation of the Jagged-1 (Jag1)-Notch signaling pathway.

Experimental Protocols

Detailed methodologies for key experiments to assess the impact of **BACE1-IN-1** on synaptic function are provided below.

Experimental Workflow for Assessing **BACE1-IN-1** Effects

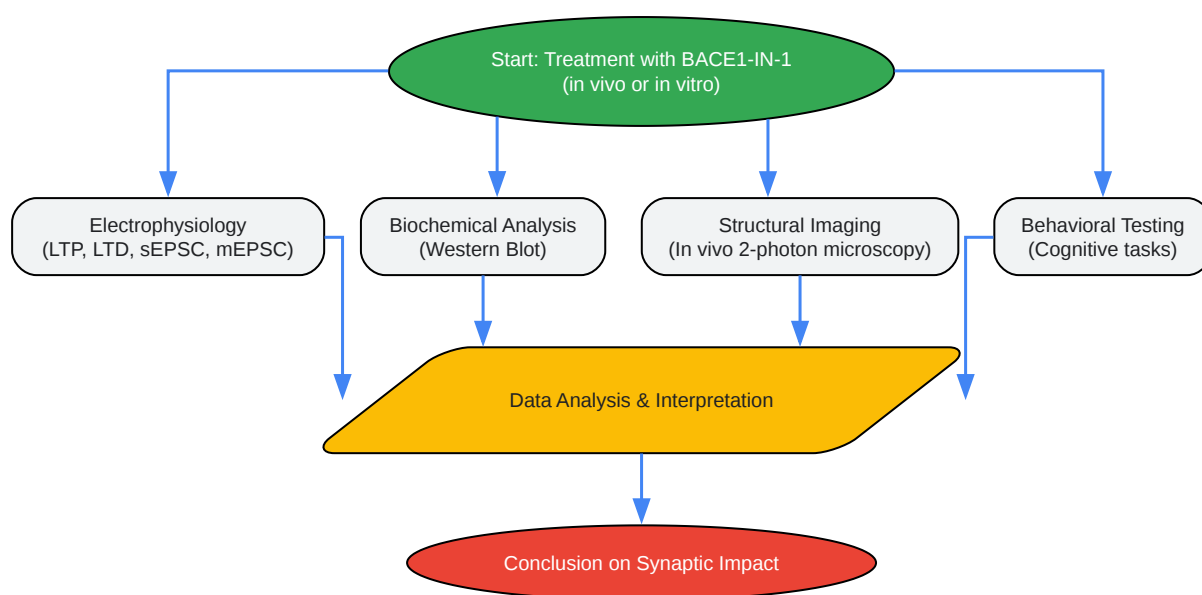

[Click to download full resolution via product page](#)

Workflow for studying **BACE1-IN-1**.

Protocol 1: Electrophysiological Recording of Long-Term Potentiation (LTP)

This protocol is adapted from methodologies described for studying synaptic plasticity in hippocampal slices.[12]

Objective: To measure the effect of **BACE1-IN-1** on LTP at Schaffer collateral-CA1 synapses in the hippocampus.

Materials:

- Adult mice
- Artificial cerebrospinal fluid (aCSF) and cutting solution
- Vibratome
- Recording chamber and perfusion system
- Glass microelectrodes
- Amplifier and data acquisition system
- **BACE1-IN-1**
- High-frequency stimulation (HFS) protocol generator

Procedure:

- Slice Preparation:
 - Anesthetize the mouse and rapidly dissect the brain.[\[12\]](#)
 - Place the brain in ice-cold, oxygenated cutting solution.
 - Cut 300-400 μm thick horizontal or coronal hippocampal slices using a vibratome.[\[12\]](#)
 - Transfer slices to a holding chamber with oxygenated aCSF and allow them to recover for at least 1 hour at room temperature.[\[12\]](#)
- Recording:
 - Transfer a slice to the recording chamber and perfuse with oxygenated aCSF at a constant rate.
 - Place a stimulating electrode in the Schaffer collateral pathway and a recording electrode in the stratum radiatum of the CA1 region to record field excitatory postsynaptic potentials (fEPSPs).

- Establish a stable baseline of fEPSPs for 20-30 minutes by delivering single pulses every 30 seconds.
- Apply **BACE1-IN-1** or vehicle control to the perfusion bath and continue baseline recording for another 20-30 minutes.
- Induce LTP using a high-frequency stimulation (HFS) protocol (e.g., three 1-second trains of 100 Hz stimulation, separated by 20 seconds).
- Record fEPSPs for at least 60 minutes post-HFS to monitor the potentiation.
- Data Analysis:
 - Measure the slope of the fEPSPs.
 - Normalize the fEPSP slope to the pre-HFS baseline.
 - Compare the degree of potentiation between **BACE1-IN-1** treated and vehicle-treated slices.

Protocol 2: Western Blotting for Synaptic Proteins

This protocol provides a general framework for analyzing changes in synaptic protein levels following **BACE1-IN-1** treatment.[\[13\]](#)[\[14\]](#)[\[15\]](#)

Objective: To determine the effect of **BACE1-IN-1** on the levels of key synaptic proteins (e.g., PSD-95, synaptophysin, Nrg1, Jag1).

Materials:

- Neuronal cultures or brain tissue from treated animals
- RIPA buffer with protease and phosphatase inhibitors
- BCA protein assay kit
- Laemmli sample buffer
- SDS-PAGE gels and electrophoresis apparatus

- PVDF or nitrocellulose membranes and transfer system
- Blocking buffer (e.g., 5% non-fat milk or BSA in TBST)
- Primary antibodies against target proteins and a loading control (e.g., β -actin, GAPDH)
- HRP-conjugated secondary antibodies
- Chemiluminescent substrate
- Imaging system

Procedure:

- Sample Preparation:
 - Treat neuronal cultures or animals with **BACE1-IN-1** or vehicle.
 - Lyse cells or homogenize tissue in RIPA buffer.[13]
 - Determine protein concentration using the BCA assay.
- Electrophoresis and Transfer:
 - Denature protein samples by boiling in Laemmli buffer.
 - Load equal amounts of protein onto an SDS-PAGE gel and perform electrophoresis.[13]
 - Transfer proteins to a PVDF membrane.[13]
- Immunoblotting:
 - Block the membrane with 5% non-fat milk or BSA in TBST for 1 hour.[13]
 - Incubate the membrane with primary antibodies overnight at 4°C.[13]
 - Wash the membrane with TBST and incubate with HRP-conjugated secondary antibodies for 1 hour at room temperature.[13]

- Detection and Analysis:
 - Wash the membrane again and apply the chemiluminescent substrate.
 - Image the blot and perform densitometric analysis, normalizing to a loading control like β -actin or GAPDH.[13]

Protocol 3: In Vivo Two-Photon Microscopy of Dendritic Spines

This advanced imaging technique allows for the longitudinal monitoring of dendritic spine dynamics in the living brain.[16][17][18]

Objective: To assess the impact of **BACE1-IN-1** on the formation, elimination, and morphology of dendritic spines over time.

Materials:

- Transgenic mice expressing fluorescent proteins in a subset of neurons (e.g., Thy1-YFP)
- Surgical tools for creating a cranial window
- Two-photon microscope with a femtosecond laser
- Anesthesia and animal monitoring equipment
- **BACE1-IN-1** administration setup

Procedure:

- Surgical Preparation:
 - Anesthetize the mouse and fix its head in a stereotaxic frame.
 - Perform a craniotomy to create a cranial window over the brain region of interest (e.g., somatosensory cortex).
 - Alternatively, a thinned-skull preparation can be used to minimize inflammation.[16][17][18]
 - Secure a glass coverslip over the exposed brain to create a stable imaging window.

- Imaging:
 - Allow the animal to recover from surgery before the first imaging session.
 - Administer **BACE1-IN-1** or vehicle according to the experimental design.
 - Anesthetize the mouse and place it under the two-photon microscope.
 - Locate the region of interest and acquire high-resolution z-stacks of dendritic segments.
 - Repeat imaging sessions at desired intervals (e.g., daily, weekly) to track changes in the same dendritic spines.
- Data Analysis:
 - Use imaging software to reconstruct 3D images of dendrites and spines.
 - Quantify spine density, turnover rate (formation and elimination), and morphology (e.g., head volume, neck length).
 - Compare these parameters between **BACE1-IN-1** treated and control animals over time.

Conclusion

The study of BACE1 inhibitors like **BACE1-IN-1** is crucial for developing effective and safe therapies for Alzheimer's disease. While reducing A β production is a primary goal, it is imperative to understand and mitigate the potential adverse effects on synaptic function due to the inhibition of BACE1's physiological roles. The protocols and information provided here offer a framework for researchers to systematically investigate the impact of BACE1 inhibition on synaptic plasticity and neuronal health. A comprehensive understanding of these dual effects will be essential for the successful clinical translation of BACE1 inhibitors.

Need Custom Synthesis?

BenchChem offers custom synthesis for rare earth carbides and specific isotopic labeling.

Email: info@benchchem.com or [Request Quote Online](#).

References

- 1. BACE1-Dependent Neuregulin-1 Signaling: An Implication for Schizophrenia - PMC [pmc.ncbi.nlm.nih.gov]
- 2. Role of BACE1 in Alzheimer's synaptic function - PMC [pmc.ncbi.nlm.nih.gov]
- 3. researchgate.net [researchgate.net]
- 4. Inhibiting BACE1 to reverse synaptic dysfunctions in Alzheimer's disease - PMC [pmc.ncbi.nlm.nih.gov]
- 5. The Alzheimer's β -secretase BACE1 localizes to normal presynaptic terminals and to dystrophic presynaptic terminals surrounding amyloid plaques - PMC [pmc.ncbi.nlm.nih.gov]
- 6. Neurological dysfunctions associated with altered BACE1-dependent Neuregulin-1 signaling - PMC [pmc.ncbi.nlm.nih.gov]
- 7. researchgate.net [researchgate.net]
- 8. β -Site Amyloid Precursor Protein Cleaving Enzyme 1(BACE1) Regulates Notch Signaling by Controlling the Cleavage of Jagged 1 (Jag1) and Jagged 2 (Jag2) Proteins - PMC [pmc.ncbi.nlm.nih.gov]
- 9. researchgate.net [researchgate.net]
- 10. BACE1 Knock-Outs Display Deficits in Activity-Dependent Potentiation of Synaptic Transmission at Mossy Fiber to CA3 Synapses in the Hippocampus - PMC [pmc.ncbi.nlm.nih.gov]
- 11. BACE1 controls synaptic function through modulating release of synaptic vesicles - PMC [pmc.ncbi.nlm.nih.gov]
- 12. pubcompare.ai [pubcompare.ai]
- 13. benchchem.com [benchchem.com]
- 14. sysy.com [sysy.com]
- 15. Western Blot Procedure | Cell Signaling Technology [cellsignal.com]
- 16. Two-Photon in vivo Imaging of Dendritic Spines in the Mouse Cortex Using a Thinned-skull Preparation - PMC [pmc.ncbi.nlm.nih.gov]
- 17. Two-photon in vivo imaging of dendritic spines in the mouse cortex using a thinned-skull preparation - PubMed [pubmed.ncbi.nlm.nih.gov]
- 18. researchgate.net [researchgate.net]

- To cite this document: BenchChem. [BACE1-IN-1: A Technical Guide to its Impact on Synaptic Function]. BenchChem, [2025]. [Online PDF]. Available at: [<https://www.benchchem.com/product/b610529#bace1-in-1-and-its-impact-on-synaptic-function>]

Disclaimer & Data Validity:

The information provided in this document is for Research Use Only (RUO) and is strictly not intended for diagnostic or therapeutic procedures. While BenchChem strives to provide accurate protocols, we make no warranties, express or implied, regarding the fitness of this product for every specific experimental setup.

Technical Support: The protocols provided are for reference purposes. Unsure if this reagent suits your experiment? [[Contact our Ph.D. Support Team for a compatibility check](#)]

Need Industrial/Bulk Grade? [Request Custom Synthesis Quote](#)

BenchChem

Our mission is to be the trusted global source of essential and advanced chemicals, empowering scientists and researchers to drive progress in science and industry.

Contact

Address: 3281 E Guasti Rd

Ontario, CA 91761, United States

Phone: (601) 213-4426

Email: info@benchchem.com