

# Application of Tereticornate A in Osteoclast Culture Models

**Author:** BenchChem Technical Support Team. **Date:** December 2025

## Compound of Interest

Compound Name: Tereticornate A

Cat. No.: B14860455

[Get Quote](#)

For Researchers, Scientists, and Drug Development Professionals

## Application Notes

**Tereticornate A**, a natural terpene ester, has been identified as a potent inhibitor of osteoclastogenesis, the process of osteoclast differentiation and activation.<sup>[1]</sup> Excessive osteoclast activity is a key factor in the pathology of bone diseases such as osteoporosis.<sup>[1]</sup> In vitro studies have demonstrated that **Tereticornate A** effectively suppresses the differentiation of osteoclast precursors into mature, bone-resorbing osteoclasts. This inhibitory effect is mediated through the disruption of key signaling pathways crucial for osteoclast development.

The primary cellular model for investigating the anti-osteoclastogenic effects of **Tereticornate A** is the murine macrophage cell line, RAW 264.7.<sup>[1]</sup> These cells, when stimulated with Receptor Activator of Nuclear Factor kappa-B Ligand (RANKL), differentiate into multinucleated, tartrate-resistant acid phosphatase (TRAP)-positive osteoclasts that are capable of forming F-actin rings, a characteristic feature of functional osteoclasts.<sup>[1]</sup>

**Tereticornate A** exerts its inhibitory effects by downregulating the expression of c-Src and TRAF6. This leads to the suppression of RANKL-stimulated signaling cascades, including the AKT, MAPK (p38, JNK, and ERK), and NF- $\kappa$ B pathways.<sup>[1]</sup> The ultimate consequence of this signaling inhibition is the downregulation of the master transcription factors for osteoclastogenesis, NFATc1 and c-Fos. This, in turn, reduces the expression of genes essential for osteoclast function, such as TRAP, cathepsin K,  $\beta$ -Integrin, and MMP-9.<sup>[1]</sup>

Currently, the known applications of **Tereticornate A** in bone cell culture are limited to osteoclast models. There is no available research on its effects on osteoblasts or bone formation. Therefore, its use as a tool compound is primarily for studying the mechanisms of osteoclast inhibition and for screening potential therapeutic agents targeting bone resorption.

## Data Presentation

The following tables summarize the reported effects of **Tereticornate A** on osteoclast differentiation and function based on available literature.

Table 1: Effect of **Tereticornate A** on Osteoclast Differentiation Markers

Marker	Effect of Tereticornate A Treatment
TRAP-positive Multinucleated Cells	Significantly Reduced
F-actin Ring Formation	Inhibited
c-Fos Expression	Downregulated
NFATc1 Expression	Downregulated

Table 2: Effect of **Tereticornate A** on Osteoclast-Related Gene Expression

Gene	Effect of Tereticornate A Treatment
TRAP	Downregulated
Cathepsin K	Downregulated
$\beta$ -Integrin	Downregulated
MMP-9	Downregulated
ATP6V0D2	Downregulated
DC-STAMP	Downregulated

Table 3: Effect of **Tereticornate A** on Key Signaling Molecules in Osteoclastogenesis

Signaling Molecule	Effect of Tereticornate A Treatment
c-Src	Downregulated
TRAF6	Downregulated
Phospho-AKT	Reduced
Phospho-p38	Reduced
Phospho-JNK	Reduced
Phospho-ERK	Reduced
NF- $\kappa$ B Activity	Inhibited

## Experimental Protocols

### Protocol 1: Culture and Differentiation of RAW 264.7 Cells into Osteoclasts

This protocol describes the standard method for culturing RAW 264.7 cells and inducing their differentiation into osteoclasts using RANKL.

Materials:

- RAW 264.7 cell line
- Dulbecco's Modified Eagle Medium (DMEM)
- Fetal Bovine Serum (FBS)
- Penicillin-Streptomycin solution
- Recombinant Murine RANKL
- Cell scraper
- Culture flasks and plates

Procedure:

- Cell Culture: Culture RAW 264.7 cells in DMEM supplemented with 10% FBS and 1% Penicillin-Streptomycin at 37°C in a humidified atmosphere of 5% CO<sub>2</sub>.
- Seeding: Seed RAW 264.7 cells in a 96-well plate at a density of  $1 \times 10^4$  cells/well.
- Differentiation Induction: After 24 hours, replace the medium with fresh medium containing 50 ng/mL of RANKL to induce osteoclast differentiation.
- Culture Maintenance: Continue the culture for 5-7 days, replacing the medium with fresh medium containing RANKL every 2 days.
- Observation: Monitor the cells daily for morphological changes, such as cell fusion and the formation of multinucleated cells, which are indicative of osteoclast differentiation.

## Protocol 2: Treatment with Tereticornate A

This protocol outlines the application of **Tereticornate A** to inhibit RANKL-induced osteoclastogenesis.

Materials:

- Differentiated RAW 264.7 cells (from Protocol 1)
- **Tereticornate A** stock solution (dissolved in a suitable solvent like DMSO)
- Culture medium

Procedure:

- Preparation of Treatment Medium: Prepare a series of dilutions of **Tereticornate A** in the culture medium. A vehicle control (medium with the solvent at the same final concentration) should also be prepared.
- Treatment: On the same day as RANKL induction (Day 0), add the **Tereticornate A** dilutions or the vehicle control to the respective wells.
- Incubation: Incubate the cells for the duration of the differentiation process (5-7 days), ensuring to replace the medium with fresh medium containing RANKL and the respective

treatments every 2 days.

## Protocol 3: Tartrate-Resistant Acid Phosphatase (TRAP) Staining

This protocol is for the identification of mature osteoclasts, which are characterized by high levels of TRAP activity.

Materials:

- Treated cells in a 96-well plate (from Protocol 2)
- Phosphate Buffered Saline (PBS)
- Fixation solution (e.g., 4% paraformaldehyde in PBS)
- TRAP staining solution kit

Procedure:

- **Washing:** At the end of the culture period, aspirate the medium and wash the cells gently with PBS.
- **Fixation:** Fix the cells with the fixation solution for 10 minutes at room temperature.
- **Washing:** Wash the cells three times with PBS.
- **Staining:** Add the TRAP staining solution to each well according to the manufacturer's instructions and incubate at 37°C for 30-60 minutes.
- **Washing:** Wash the cells with distilled water.
- **Analysis:** Visualize the cells under a microscope. TRAP-positive cells will appear red/purple. Count the number of TRAP-positive multinucleated cells (containing three or more nuclei) in each well.

## Protocol 4: F-actin Ring Formation Assay

This assay is used to visualize the actin cytoskeleton, specifically the formation of F-actin rings, which are essential for the bone-resorbing activity of osteoclasts.

Materials:

- Treated cells cultured on glass coverslips or bone slices
- PBS
- Fixation solution (e.g., 4% paraformaldehyde in PBS)
- Permeabilization solution (e.g., 0.1% Triton X-100 in PBS)
- Phalloidin conjugated to a fluorescent dye (e.g., TRITC-phalloidin)
- DAPI (for nuclear staining)
- Mounting medium

Procedure:

- **Washing and Fixation:** Follow steps 1 and 2 from the TRAP staining protocol.
- **Permeabilization:** Permeabilize the cells with the permeabilization solution for 5 minutes.
- **Washing:** Wash the cells three times with PBS.
- **Staining:** Incubate the cells with the fluorescently labeled phalloidin solution for 30-60 minutes at room temperature in the dark.
- **Nuclear Staining:** Counterstain the nuclei with DAPI for 5 minutes.
- **Washing:** Wash the cells three times with PBS.
- **Mounting and Visualization:** Mount the coverslips onto microscope slides using a mounting medium and visualize the F-actin rings using a fluorescence microscope.

## Visualizations

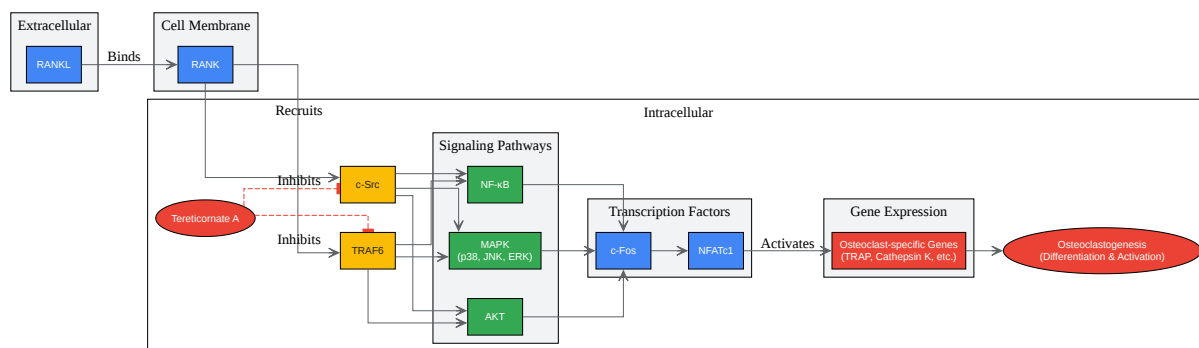



[Click to download full resolution via product page](#)

**Need Custom Synthesis?**

BenchChem offers custom synthesis for rare earth carbides and specific isotopic labeling.

Email: [info@benchchem.com](mailto:info@benchchem.com) or [Request Quote Online](#).

**References**

- 1. Tereticornate A suppresses RANKL-induced osteoclastogenesis via the downregulation of c-Src and TRAF6 and the inhibition of RANK signaling pathways - PubMed [pubmed.ncbi.nlm.nih.gov]
- To cite this document: BenchChem. [Application of Tereticornate A in Osteoclast Culture Models]. BenchChem, [2025]. [Online PDF]. Available at:



[<https://www.benchchem.com/product/b14860455#application-of-tereticornate-a-in-bone-cell-culture-models>]

---

### Disclaimer & Data Validity:

The information provided in this document is for Research Use Only (RUO) and is strictly not intended for diagnostic or therapeutic procedures. While BenchChem strives to provide accurate protocols, we make no warranties, express or implied, regarding the fitness of this product for every specific experimental setup.

**Technical Support:** The protocols provided are for reference purposes. Unsure if this reagent suits your experiment? [[Contact our Ph.D. Support Team for a compatibility check](#)]

**Need Industrial/Bulk Grade?** [Request Custom Synthesis Quote](#)

## BenchChem

Our mission is to be the trusted global source of essential and advanced chemicals, empowering scientists and researchers to drive progress in science and industry.

### Contact

Address: 3281 E Guasti Rd  
Ontario, CA 91761, United States  
Phone: (601) 213-4426  
Email: [info@benchchem.com](mailto:info@benchchem.com)