

Application of Teicoplanin A3-1 in studies of bacterial cell wall synthesis.

Author: BenchChem Technical Support Team. **Date:** December 2025

Compound of Interest

Compound Name: *Teicoplanin A3-1*

Cat. No.: *B021161*

[Get Quote](#)

Application of Teicoplanin A3-1 in Studies of Bacterial Cell Wall Synthesis

For Researchers, Scientists, and Drug Development Professionals

Introduction

Teicoplanin is a glycopeptide antibiotic that serves as a critical tool in the study of bacterial cell wall biosynthesis. It is a mixture of several compounds, with **Teicoplanin A3-1** being the common glycopeptide core for all.[1][2] Its specific mechanism of action, targeting the D-alanyl-D-alanine (D-Ala-D-Ala) termini of peptidoglycan precursors, makes it an invaluable probe for investigating the intricate processes of cell wall construction in Gram-positive bacteria.[3][4][5] These application notes provide an overview of the use of **Teicoplanin A3-1** in this field, including quantitative data on its activity and detailed protocols for key experiments.

Teicoplanin A3-1 exerts its antibacterial effect by inhibiting the synthesis of the bacterial cell wall. It specifically binds to the D-Ala-D-Ala residues of the nascent peptidoglycan chains, thereby sterically hindering the transglycosylation and transpeptidation reactions. These reactions are essential for the polymerization of the glycan chains and the cross-linking of the peptide side chains, respectively, which together form the rigid peptidoglycan meshwork that protects the bacterial cell. By disrupting this process, **Teicoplanin A3-1** leads to the formation of a defective cell wall, ultimately causing cell lysis and bacterial death.

Data Presentation

The following tables summarize the quantitative data regarding the inhibitory activity and binding affinity of teicoplanin. While much of the available data pertains to teicoplanin as a mixture, it provides a strong indication of the activity of its core component, **Teicoplanin A3-1**.

Table 1: Minimum Inhibitory Concentrations (MICs) of Teicoplanin against various Gram-positive bacteria.

Bacterial Species	Strain Type	MIC Range ($\mu\text{g/mL}$)	Reference
Staphylococcus aureus	Methicillin-Resistant (MRSA)	0.25 - 8	
Staphylococcus aureus	-	≤ 0.06 - ≥ 128	
Staphylococcus epidermidis	-	≤ 0.06 - 32	
Streptococcus faecalis	-	0.12 - 0.5	
Streptococcus pneumoniae	-	≤ 0.015 - 0.03	
Other Streptococci	-	≤ 0.015 - 0.25	

Table 2: Binding Affinity of Teicoplanin for Peptidoglycan Precursors.

Ligand	Method	Dissociation Constant (Kd)	Reference
Carrier protein-Lys-d-Ala-d-Ala fusion	Surface Plasmon Resonance (SPR)	91 ± 7 nM	
Free Lys-d-Ala-d-Ala peptide	Surface Plasmon Resonance (SPR)	474 ± 20 nM	
VanSA Receptor	Circular Dichroism (CD)	30 μM and 170 μM	

Experimental Protocols

Determination of Minimum Inhibitory Concentration (MIC) by Broth Microdilution

This protocol outlines the determination of the MIC of **Teicoplanin A3-1** against a bacterial strain using the broth microdilution method.

Materials:

- **Teicoplanin A3-1** stock solution (prepared in a suitable solvent, e.g., water or DMSO)
- Cation-adjusted Mueller-Hinton Broth (CAMHB)
- Bacterial culture in logarithmic growth phase
- Sterile 96-well microtiter plates
- Spectrophotometer or microplate reader

Procedure:

- Prepare Bacterial Inoculum:
 - Aseptically pick 3-5 colonies of the test bacterium from an agar plate and inoculate into a tube of sterile broth.
 - Incubate at 35-37°C until the culture reaches the turbidity of a 0.5 McFarland standard (approximately $1-2 \times 10^8$ CFU/mL).
 - Dilute the standardized inoculum in CAMHB to achieve a final concentration of approximately 5×10^5 CFU/mL in the test wells.
- Prepare **Teicoplanin A3-1** Dilutions:
 - Perform serial two-fold dilutions of the **Teicoplanin A3-1** stock solution in CAMHB in the 96-well microtiter plate. The final volume in each well should be 50 μ L. The concentration range should be chosen to bracket the expected MIC.

- Inoculation:
 - Add 50 μ L of the diluted bacterial inoculum to each well containing the **Teicoplanin A3-1** dilutions and to a growth control well (containing only CAMHB and inoculum).
 - The final volume in each well will be 100 μ L.
- Incubation:
 - Incubate the microtiter plate at 35-37°C for 16-20 hours in ambient air.
- Reading the MIC:
 - The MIC is defined as the lowest concentration of **Teicoplanin A3-1** that completely inhibits visible growth of the organism, as detected by the unaided eye or by measuring the optical density at 600 nm.

Analysis of Teicoplanin A3-1 Binding to D-Ala-D-Ala using Surface Plasmon Resonance (SPR)

This protocol provides a general framework for analyzing the binding kinetics of **Teicoplanin A3-1** to a synthetic peptide terminating in D-Ala-D-Ala using SPR.

Materials:

- SPR instrument (e.g., Biacore)
- Sensor chip (e.g., CM5)
- Amine coupling kit (containing N-hydroxysuccinimide (NHS), 1-ethyl-3-(3-dimethylaminopropyl)carbodiimide hydrochloride (EDC), and ethanolamine)
- Synthetic peptide with a terminal D-Ala-D-Ala sequence and a functional group for immobilization (e.g., an N-terminal amine)
- **Teicoplanin A3-1**
- Running buffer (e.g., HBS-EP+)

Procedure:

- Ligand Immobilization:
 - Activate the carboxymethylated dextran surface of the sensor chip by injecting a mixture of NHS and EDC.
 - Inject the D-Ala-D-Ala peptide solution over the activated surface to allow for covalent coupling via amine groups.
 - Deactivate any remaining active esters by injecting ethanolamine.
 - A reference flow cell should be prepared in the same way but without the peptide immobilization.
- Binding Analysis:
 - Inject a series of concentrations of **Teicoplanin A3-1** (analyte) over both the peptide-immobilized and reference flow cells at a constant flow rate.
 - Monitor the change in the SPR signal (response units, RU) in real-time. The signal is proportional to the mass of analyte binding to the immobilized ligand.
- Data Analysis:
 - Subtract the reference flow cell data from the active flow cell data to correct for bulk refractive index changes and non-specific binding.
 - Analyze the resulting sensorgrams (plots of RU versus time) using appropriate kinetic models (e.g., 1:1 Langmuir binding) to determine the association rate constant (k_a), dissociation rate constant (k_d), and the equilibrium dissociation constant ($K_d = k_d/k_a$).

Characterization of Teicoplanin A3-1 Binding by Isothermal Titration Calorimetry (ITC)

This protocol describes the use of ITC to determine the thermodynamic parameters of **Teicoplanin A3-1** binding to a D-Ala-D-Ala containing peptide.

Materials:

- Isothermal titration calorimeter
- **Teicoplanin A3-1** solution
- Synthetic peptide with a terminal D-Ala-D-Ala sequence
- Matching buffer for both solutions

Procedure:

- Sample Preparation:
 - Prepare a solution of the D-Ala-D-Ala peptide in a suitable buffer (e.g., phosphate-buffered saline) at a known concentration (typically 10-100 μM) to be placed in the sample cell.
 - Prepare a solution of **Teicoplanin A3-1** in the same buffer at a concentration 10-20 times higher than the peptide concentration to be placed in the injection syringe.
 - Degas both solutions to prevent bubble formation during the experiment.
- ITC Experiment:
 - Load the peptide solution into the sample cell and the **Teicoplanin A3-1** solution into the injection syringe.
 - Equilibrate the system at the desired temperature.
 - Perform a series of small, sequential injections of the **Teicoplanin A3-1** solution into the sample cell.
 - The instrument measures the heat released or absorbed during each injection.
- Data Analysis:
 - Integrate the heat flow peaks for each injection to obtain the heat change per injection.

- Plot the heat change per mole of injectant against the molar ratio of **Teicoplanin A3-1** to the peptide.
- Fit the resulting binding isotherm to a suitable binding model to determine the binding affinity (K_a or K_d), stoichiometry (n), and the enthalpy of binding (ΔH). The entropy of binding (ΔS) can then be calculated using the equation: $\Delta G = \Delta H - T\Delta S = -RT\ln K_a$.

Mandatory Visualization

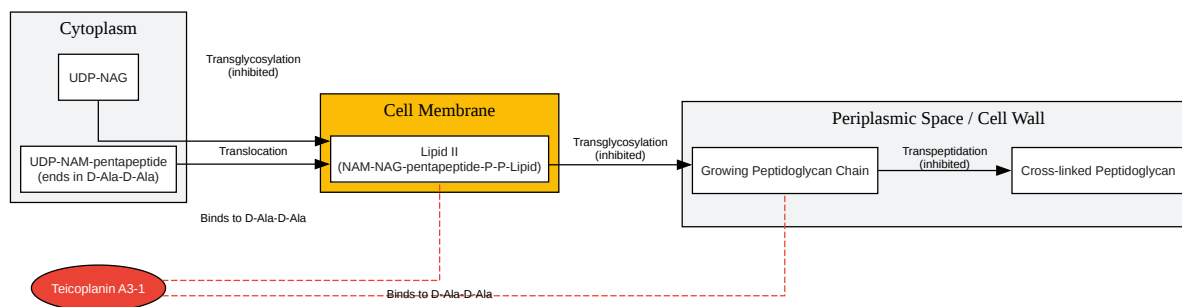

[Click to download full resolution via product page](#)

Caption: Mechanism of action of **Teicoplanin A3-1**.

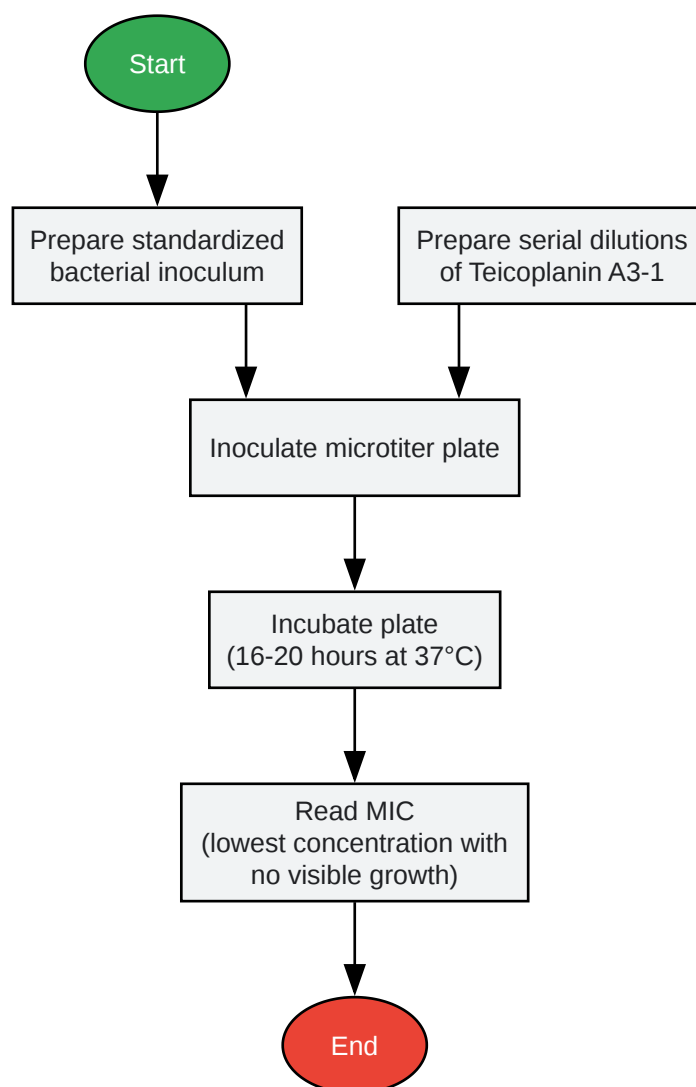

[Click to download full resolution via product page](#)

Caption: Experimental workflow for MIC determination.

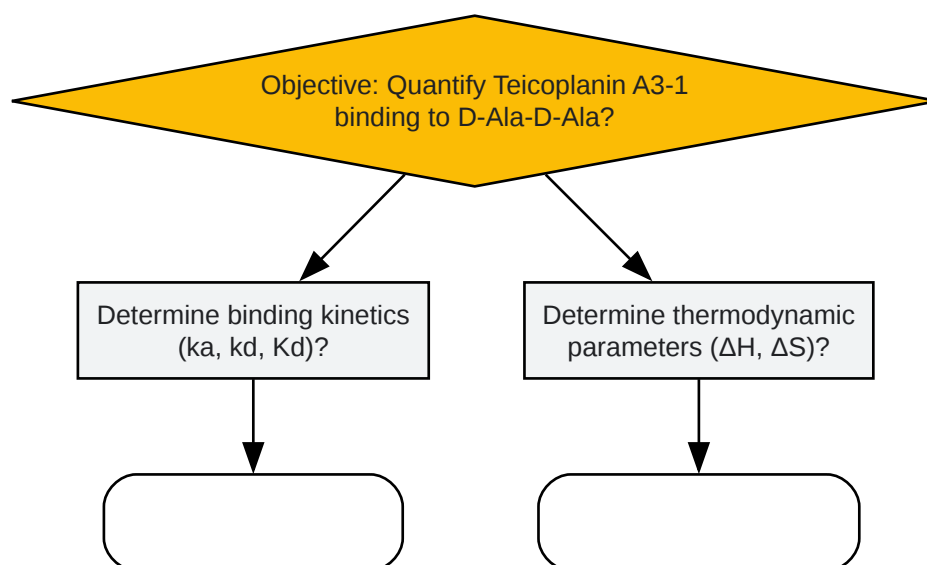

[Click to download full resolution via product page](#)

Caption: Logical flow for selecting a binding affinity assay.

Need Custom Synthesis?

BenchChem offers custom synthesis for rare earth carbides and specific isotopic labeling.

Email: info@benchchem.com or [Request Quote Online](#).

References

- 1. Characterisation of the selective binding of antibiotics vancomycin and teicoplanin by the VanS receptor regulating type A vancomycin resistance in the enterococci - PMC [pmc.ncbi.nlm.nih.gov]
- 2. A Review of Teicoplanin Used in the Prevention and Treatment of Serious Infections Caused by Gram-Positive Bacteria and Compared Its Effects with Some other Antibiotics – Biomedical and Pharmacology Journal [biomedpharmajournal.org]
- 3. In vitro activity of teicoplanin and vancomycin against gram-positive bacteria from human clinical and veterinary sources - PubMed [pubmed.ncbi.nlm.nih.gov]
- 4. researchgate.net [researchgate.net]
- 5. Microbiological properties of teicoplanin - PubMed [pubmed.ncbi.nlm.nih.gov]

- To cite this document: BenchChem. [Application of Teicoplanin A3-1 in studies of bacterial cell wall synthesis.]. BenchChem, [2025]. [Online PDF]. Available at: [<https://www.benchchem.com/product/b021161#application-of-teicoplanin-a3-1-in-studies-of-bacterial-cell-wall-synthesis>]

Disclaimer & Data Validity:

The information provided in this document is for Research Use Only (RUO) and is strictly not intended for diagnostic or therapeutic procedures. While BenchChem strives to provide accurate protocols, we make no warranties, express or implied, regarding the fitness of this product for every specific experimental setup.

Technical Support: The protocols provided are for reference purposes. Unsure if this reagent suits your experiment? [[Contact our Ph.D. Support Team for a compatibility check](#)]

Need Industrial/Bulk Grade? [Request Custom Synthesis Quote](#)

BenchChem

Our mission is to be the trusted global source of essential and advanced chemicals, empowering scientists and researchers to drive progress in science and industry.

Contact

Address: 3281 E Guasti Rd

Ontario, CA 91761, United States

Phone: (601) 213-4426

Email: info@benchchem.com