

Application of MART-1 (26-35) in Immunotherapy Research Models

Author: BenchChem Technical Support Team. **Date:** December 2025

Compound of Interest

Compound Name: MART-1 (26-35) (human)

Cat. No.: B12461148

[Get Quote](#)

For Researchers, Scientists, and Drug Development Professionals

Introduction

The Melanoma Antigen Recognized by T-cells 1 (MART-1), also known as Melan-A, is a key protein expressed in normal melanocytes and a majority of melanoma tumors.[1][2][3] A specific peptide fragment of this protein, MART-1 (26-35), and its analog with a leucine substitution at position 27 (27L), have been identified as immunodominant epitopes recognized by cytotoxic T lymphocytes (CTLs) in the context of the HLA-A02:01 allele.[1][4][5] This recognition makes the MART-1 (26-35) peptide a critical tool in the development and evaluation of immunotherapies for melanoma, including cancer vaccines and adoptive cell transfer (ACT). [2][3] The 27L analog (ELAGIGILTV) has demonstrated enhanced immunogenicity due to its increased binding affinity and stability with the HLA-A02:01 molecule compared to the wild-type sequence (EAAGIGILTV).[1][3][4][6] These peptides are extensively used in preclinical and clinical research to stimulate and expand tumor-specific T-cells, assess their functionality, and predict patient responses to therapy.[2][7][8][9]

Core Applications

The primary applications of the MART-1 (26-35) peptide in immunotherapy research models include:

- In vitro expansion of MART-1 specific T-cells: The peptide is used to stimulate peripheral blood mononuclear cells (PBMCs) or tumor-infiltrating lymphocytes (TILs) from HLA-A*02:01

positive donors to generate and expand T-cell populations with specificity for the MART-1 antigen.[\[1\]](#)[\[10\]](#)

- Assessment of T-cell functionality: Expanded T-cells are evaluated for their cytotoxic potential against melanoma cells and their ability to secrete effector cytokines, such as interferon-gamma (IFN- γ), upon peptide recognition.[\[1\]](#)[\[11\]](#)
- Preclinical evaluation of cancer vaccines: In HLA-A*02:01 transgenic mouse models, the MART-1 (26-35) peptide is used as an immunogen to test the efficacy of different vaccine formulations and adjuvants.[\[12\]](#)[\[13\]](#)
- Monitoring of immune responses in clinical trials: The peptide is utilized in immunological assays, such as ELISPOT and tetramer staining, to quantify the frequency and function of MART-1 specific T-cells in patients undergoing immunotherapy.[\[11\]](#)[\[14\]](#)

Data Summary

Peptide Analogs and Binding Affinity

Peptide Sequence	Description	Key Characteristics	Reference
EAAGIGILTV	Wild-type MART-1 (26-35)	The naturally occurring decapeptide.	[4] [5]
AAGIGILTV	Wild-type MART-1 (27-35)	The naturally occurring nonapeptide, also recognized by CTLs.	[4] [5]
ELAGIGILTV	MART-1 (26-35, 27L)	An analog with an Alanine to Leucine substitution at position 27 (position 2 of the nonamer core).	[1] [3] [4] [12]

In Vitro T-Cell Stimulation and Functional Assays

Parameter	Typical Range/Value	Purpose	Reference
Peptide Concentration for T-cell Stimulation	1-10 µg/mL	Loading antigen-presenting cells (APCs) for T-cell expansion.	[15][16]
Effector to Target (E:T) Ratio for Cytotoxicity Assays	1:1 to 40:1	To measure the lytic capacity of MART-1 specific CTLs against target cells.	[17]
Peptide Concentration for Target Cell Pulsing	10 fM - 10 µM	To sensitize target cells for recognition by CTLs in functional assays.	[15]
IL-2 Concentration for T-cell Culture	10 IU/mL - 300 IU/mL	To support the proliferation and survival of activated T-cells.	[10][15]
IL-7 and IL-15 Concentration for T-cell Culture	5-10 ng/mL	To promote the generation of less differentiated, memory-like T-cells.	[10][18]

Experimental Protocols

Protocol 1: In Vitro Expansion of MART-1 Specific CD8+ T-Cells

This protocol outlines the steps for generating and expanding MART-1 specific CD8+ T-cells from peripheral blood mononuclear cells (PBMCs) of an HLA-A*02:01 positive donor.

Materials:

- Ficoll-Paque

- RPMI 1640 medium supplemented with 10% fetal bovine serum (FBS), 2 mM L-glutamine, and 1% penicillin-streptomycin
- Human IL-2, IL-7, and IL-15
- MART-1 (26-35, 27L) peptide (ELAGIGILTV)
- T2 cells (HLA-A*02:01+, TAP-deficient)
- CD8+ T-cell isolation kit

Procedure:

- Isolate PBMCs: Isolate PBMCs from whole blood using Ficoll-Paque density gradient centrifugation.
- Isolate CD8+ T-cells: Enrich for CD8+ T-cells from the PBMC population using a positive or negative selection kit according to the manufacturer's instructions.
- Prepare Antigen-Presenting Cells (APCs):
 - Culture T2 cells in complete RPMI 1640 medium.
 - On the day of stimulation, pulse the T2 cells with the MART-1 (26-35, 27L) peptide at a concentration of 10 µg/mL for 2 hours at 37°C.
 - Irradiate the peptide-pulsed T2 cells (30 Gy) to prevent their proliferation.
- Co-culture and Stimulation:
 - Co-culture the isolated CD8+ T-cells with the irradiated, peptide-pulsed T2 cells at a responder-to-stimulator ratio of 10:1 in complete RPMI 1640 medium.
 - Supplement the co-culture medium with IL-7 and IL-15 at a final concentration of 10 ng/mL each.
- T-cell Expansion:

- After 2-3 days, add IL-2 to the culture medium at a final concentration of 50 IU/mL.
- Restimulate the T-cell cultures every 7-10 days with freshly prepared, irradiated, peptide-pulsed T2 cells.
- Maintain the T-cell cultures by splitting them as needed and adding fresh medium containing IL-2.
- **Monitoring Specificity:** The frequency of MART-1 specific T-cells can be monitored throughout the expansion process using HLA-A*02:01/MART-1 tetramer staining followed by flow cytometry analysis.

Protocol 2: IFN- γ ELISPOT Assay

This protocol describes how to measure the frequency of IFN- γ secreting, MART-1 specific T-cells.

Materials:

- Human IFN- γ ELISPOT kit
- 96-well PVDF membrane plates
- MART-1 (26-35, 27L) peptide
- T2 cells
- Expanded MART-1 specific T-cells (from Protocol 1)
- Phytohemagglutinin (PHA) as a positive control
- An irrelevant peptide as a negative control

Procedure:

- **Plate Coating:** Coat a 96-well PVDF plate with an anti-IFN- γ capture antibody overnight at 4°C, according to the ELISPOT kit manufacturer's instructions.
- **Cell Preparation:**

- Wash the expanded MART-1 specific T-cells and resuspend them in complete RPMI 1640 medium.
- Pulse T2 cells with the MART-1 (26-35, 27L) peptide (10 µg/mL), an irrelevant peptide, or no peptide for 2 hours at 37°C.
- Plating Cells:
 - Add 2×10^4 T2 cells (pulsed with MART-1 peptide, irrelevant peptide, or no peptide) to the appropriate wells of the coated ELISPOT plate.
 - Add 2×10^4 expanded MART-1 specific T-cells to each well.
 - For the positive control, add T-cells and PHA.
 - For the negative control, add T-cells and T2 cells pulsed with an irrelevant peptide.
- Incubation: Incubate the plate for 18-24 hours at 37°C in a 5% CO₂ incubator.
- Development:
 - Wash the plate and add the biotinylated anti-IFN-γ detection antibody.
 - Incubate, wash, and then add streptavidin-alkaline phosphatase.
 - Finally, add the substrate solution and wait for spots to develop.
- Analysis: Stop the reaction by washing with water. Allow the plate to dry and count the spots using an ELISPOT reader. Each spot represents a single IFN-γ secreting cell.

Protocol 3: Cytotoxicity (Chromium Release) Assay

This protocol details a standard method to assess the lytic capability of MART-1 specific CTLs.

Materials:

- Expanded MART-1 specific T-cells (effector cells)
- T2 cells or a melanoma cell line expressing HLA-A*02:01 (target cells)

- MART-1 (26-35, 27L) peptide
- Sodium chromate (51Cr)
- Fetal bovine serum (FBS)
- Triton X-100 (for maximum release)
- Gamma counter

Procedure:

- Target Cell Labeling:
 - Resuspend 1×10^6 target cells in 100 μ L of FBS.
 - Add 100 μ Ci of 51Cr and incubate for 1-2 hours at 37°C, mixing every 15 minutes.
 - Wash the labeled target cells three times with complete RPMI 1640 medium.
- Peptide Pulsing:
 - Resuspend the labeled target cells in complete RPMI 1640 medium.
 - Pulse the cells with the MART-1 (26-35, 27L) peptide at a concentration of 10 μ g/mL for 1 hour at 37°C.
- Co-incubation:
 - Plate the peptide-pulsed, 51Cr-labeled target cells at 5×10^3 cells/well in a 96-well round-bottom plate.
 - Add the expanded MART-1 specific T-cells at various effector-to-target (E:T) ratios (e.g., 40:1, 20:1, 10:1, 5:1).
 - For spontaneous release, add medium only to the target cells.
 - For maximum release, add 1% Triton X-100 to the target cells.

- Incubation: Centrifuge the plate at 50 x g for 3 minutes and incubate for 4 hours at 37°C.
- Harvesting and Counting:
 - Centrifuge the plate at 200 x g for 5 minutes.
 - Carefully collect 100 µL of supernatant from each well.
 - Measure the radioactivity (counts per minute, CPM) in the supernatant using a gamma counter.
- Calculation of Specific Lysis:
 - Calculate the percentage of specific lysis using the following formula: % Specific Lysis = $[(\text{Experimental Release} - \text{Spontaneous Release}) / (\text{Maximum Release} - \text{Spontaneous Release})] \times 100$

Visualizations

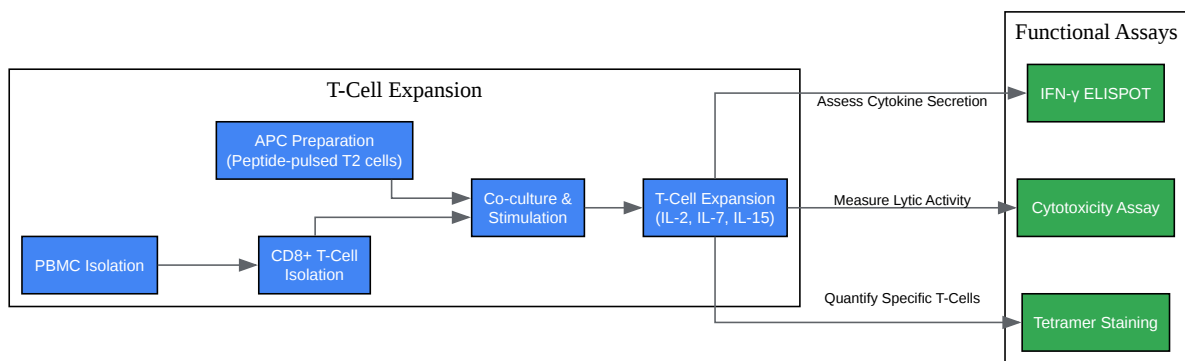

[Click to download full resolution via product page](#)

Caption: Workflow for the expansion and functional analysis of MART-1 specific T-cells.

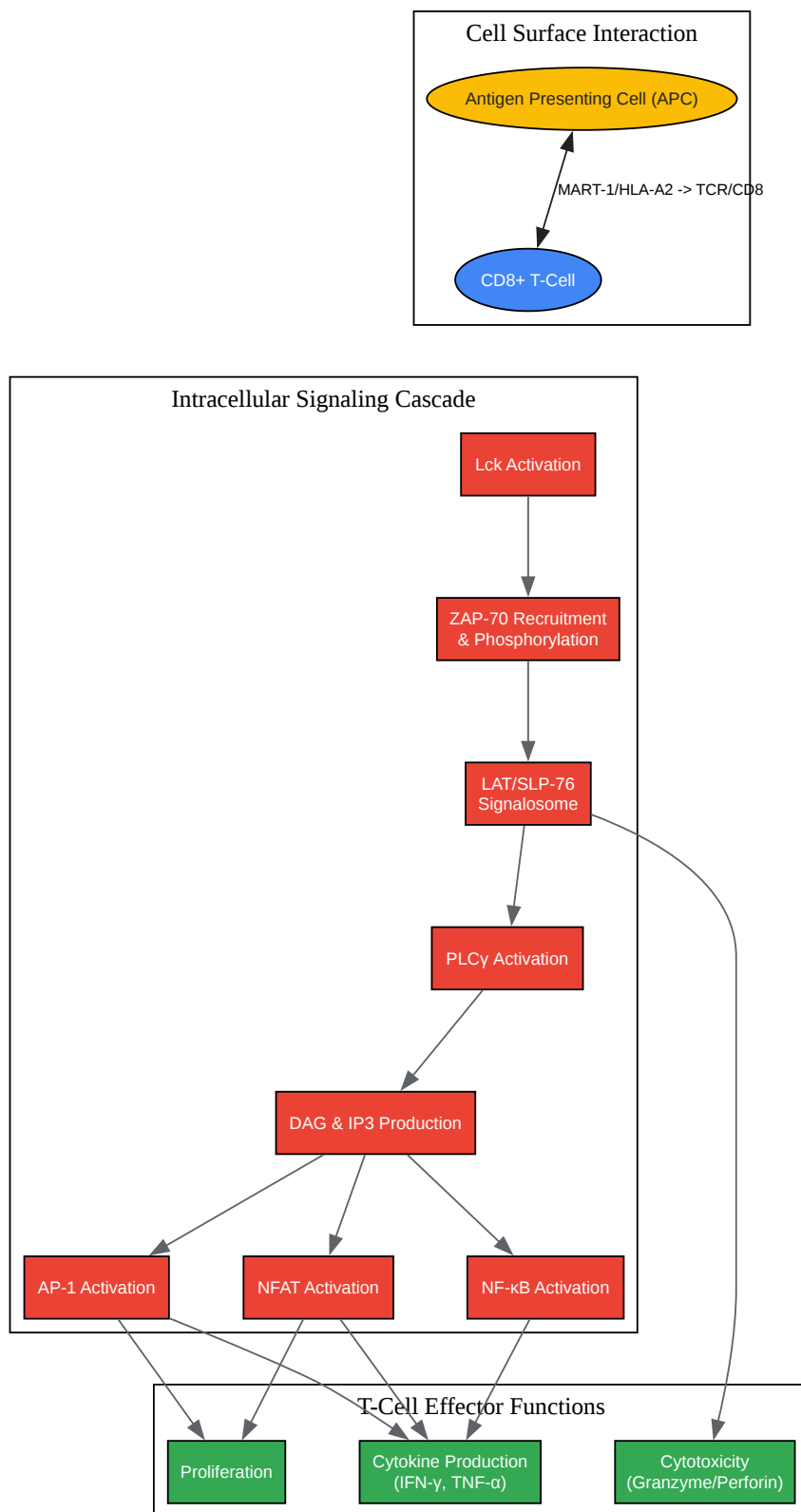

[Click to download full resolution via product page](#)

Caption: Simplified TCR signaling pathway upon MART-1 peptide recognition.

Need Custom Synthesis?

BenchChem offers custom synthesis for rare earth carbides and specific isotopic labeling.

Email: info@benchchem.com or [Request Quote Online](#).

References

- 1. ignytebio.com [ignytebio.com]
- 2. criver.com [criver.com]
- 3. bpsbioscience.com [bpsbioscience.com]
- 4. Enhanced generation of specific tumor-reactive CTL in vitro by selected Melan-A/MART-1 immunodominant peptide analogues - PubMed [pubmed.ncbi.nlm.nih.gov]
- 5. Structures of MART-126/27–35 Peptide/HLA-A2 Complexes Reveal a Remarkable Disconnect between Antigen Structural Homology and T Cell Recognition - PMC [pmc.ncbi.nlm.nih.gov]
- 6. [Leu27]-Melan-A, MART-1 (26-35) - 1 mg [anaspec.com]
- 7. Facebook [cancer.gov]
- 8. ClinicalTrials.gov [clinicaltrials.gov]
- 9. ClinicalTrials.gov [clinicaltrials.gov]
- 10. MART-1 TCR gene-modified peripheral blood T cells for the treatment of metastatic melanoma: a phase I/IIa clinical trial - PMC [pmc.ncbi.nlm.nih.gov]
- 11. jitc.bmj.com [jitc.bmj.com]
- 12. aacrjournals.org [aacrjournals.org]
- 13. researchgate.net [researchgate.net]
- 14. aacrjournals.org [aacrjournals.org]
- 15. mdpi.com [mdpi.com]
- 16. US8119772B2 - MART-1 T cell receptors - Google Patents [patents.google.com]
- 17. researchgate.net [researchgate.net]
- 18. stemcell.com [stemcell.com]
- To cite this document: BenchChem. [Application of MART-1 (26-35) in Immunotherapy Research Models]. BenchChem, [2025]. [Online PDF]. Available at:

[<https://www.benchchem.com/product/b12461148#application-of-mart-1-26-35-in-immunotherapy-research-models>]

Disclaimer & Data Validity:

The information provided in this document is for Research Use Only (RUO) and is strictly not intended for diagnostic or therapeutic procedures. While BenchChem strives to provide accurate protocols, we make no warranties, express or implied, regarding the fitness of this product for every specific experimental setup.

Technical Support: The protocols provided are for reference purposes. Unsure if this reagent suits your experiment? [[Contact our Ph.D. Support Team for a compatibility check](#)]

Need Industrial/Bulk Grade? [Request Custom Synthesis Quote](#)

BenchChem

Our mission is to be the trusted global source of essential and advanced chemicals, empowering scientists and researchers to drive progress in science and industry.

Contact

Address: 3281 E Guasti Rd
Ontario, CA 91761, United States
Phone: (601) 213-4426
Email: info@benchchem.com