

Application of 2D NMR for Steroid Structure Elucidation: Application Notes and Protocols

Author: BenchChem Technical Support Team. **Date:** December 2025

Compound of Interest

Compound Name: 2-Methylestra-4,9-dien-3-one-17-
ol

Cat. No.: B034633

[Get Quote](#)

For Researchers, Scientists, and Drug Development Professionals

This document provides a comprehensive guide to the application of two-dimensional Nuclear Magnetic Resonance (2D NMR) spectroscopy for the structural elucidation of steroids. It includes detailed application notes, experimental protocols for key 2D NMR techniques, and a complete NMR data set for testosterone as a representative example.

Introduction

The rigid tetracyclic core of steroids presents a significant challenge for complete structural characterization due to severe proton signal overlap in one-dimensional (1D) ^1H NMR spectra. [1] 2D NMR spectroscopy overcomes this limitation by dispersing signals across a second frequency dimension, revealing correlations between nuclei that are essential for unambiguous structure determination. [1][2] These techniques are indispensable for determining the carbon skeleton connectivity and the relative stereochemistry of these complex molecules.

The standard suite of 2D NMR experiments for steroid structure elucidation includes:

- COSY (Correlation Spectroscopy): To identify proton-proton (^1H - ^1H) spin-spin couplings, revealing adjacent protons. [3][4][5]
- HSQC (Heteronuclear Single Quantum Coherence): To correlate protons with their directly attached carbons (^1H - ^{13}C one-bond correlations). [6][7]

- HMBC (Heteronuclear Multiple Bond Correlation): To identify longer-range correlations between protons and carbons (^1H - ^{13}C two- to four-bond correlations), crucial for connecting spin systems and identifying quaternary carbons.[8][9]
- NOESY (Nuclear Overhauser Effect Spectroscopy): To identify protons that are close in space (through-space correlations), which is vital for determining stereochemistry.[10][11]

Logical Workflow for Steroid Structure Elucidation using 2D NMR

The process of elucidating a steroid's structure using 2D NMR follows a logical progression. Starting with simpler 1D experiments, the complexity of the analysis increases with each 2D experiment, gradually building a complete picture of the molecule's structure.

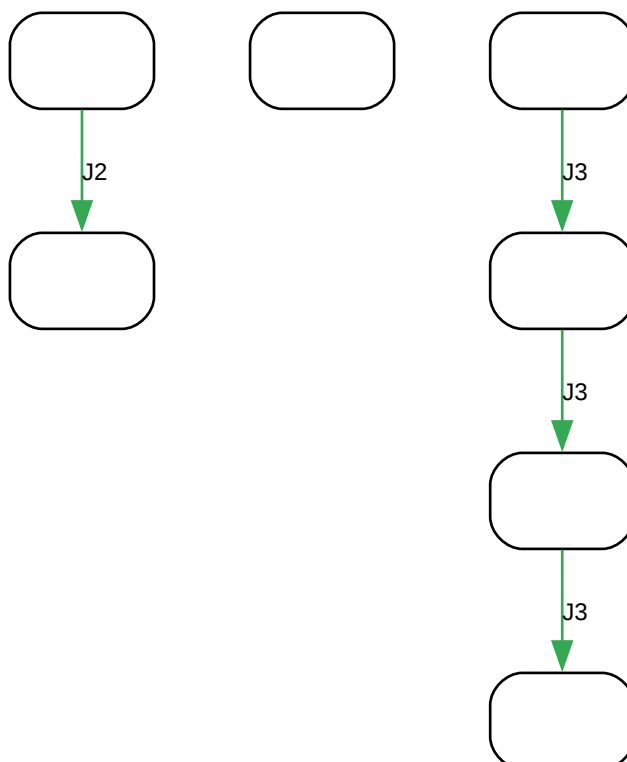
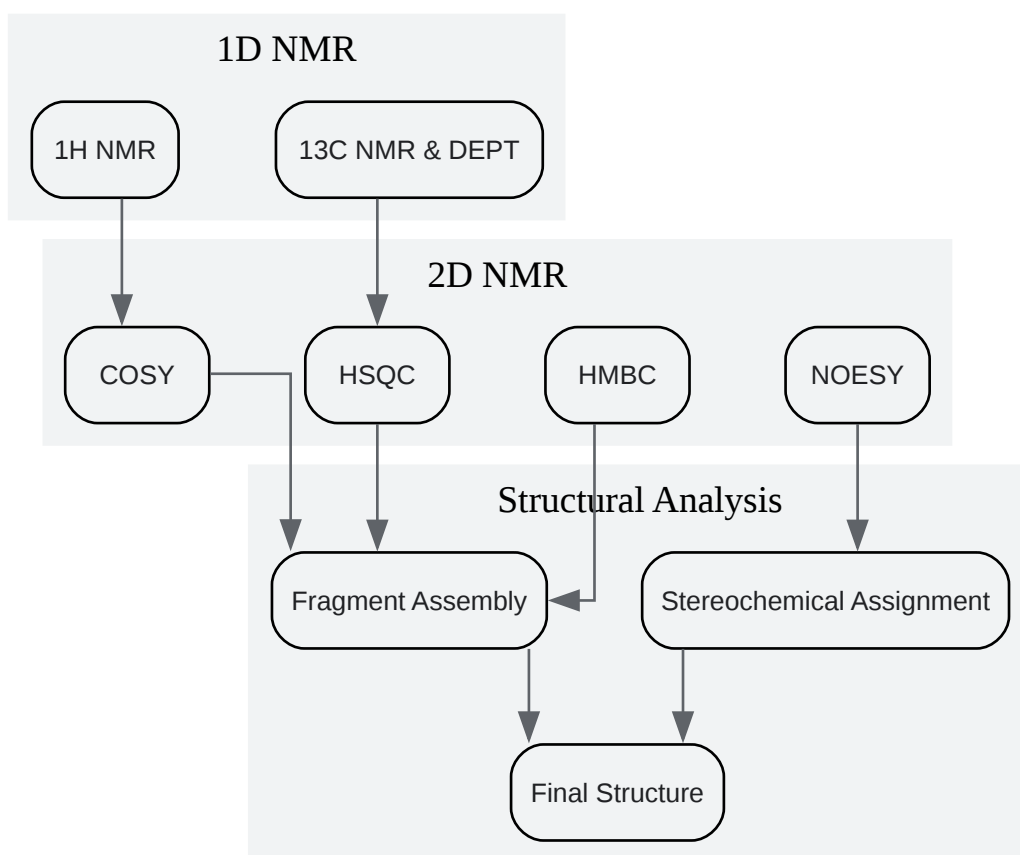

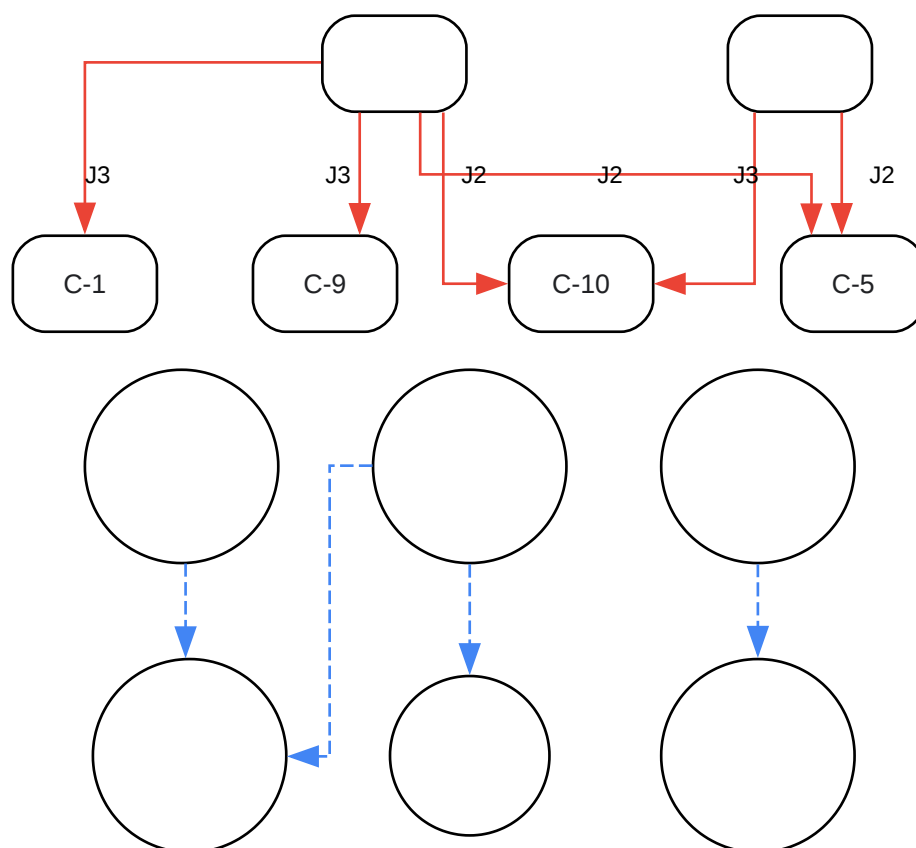

[Click to download full resolution via product page](#)

Need Custom Synthesis?

BenchChem offers custom synthesis for rare earth carbides and specific isotopic labeling.

Email: info@benchchem.com or [Request Quote Online](#).

References

- 1. books.rsc.org [books.rsc.org]
- 2. iosrjournals.org [iosrjournals.org]
- 3. ORGANIC SPECTROSCOPY INTERNATIONAL: COSY NMR [orgspectroscopyint.blogspot.com]
- 4. chem.libretexts.org [chem.libretexts.org]
- 5. Two-dimensional nuclear magnetic resonance spectroscopy - Wikipedia [en.wikipedia.org]

- 6. Heteronuclear Single-quantum Correlation (HSQC) NMR – Advances in Polymer Science [ncstate.pressbooks.pub]
- 7. web.ncbr.muni.cz [web.ncbr.muni.cz]
- 8. Leveraging the HMBC to Facilitate Metabolite Identification - PMC [pmc.ncbi.nlm.nih.gov]
- 9. nmr.chem.columbia.edu [nmr.chem.columbia.edu]
- 10. NOE Experiments | Faculty of Mathematical & Physical Sciences [ucl.ac.uk]
- 11. NOESY: the experiment for when you just need to know more, particularly the 1H-1H spatial proximity — Nanalysis [nanalysis.com]
- To cite this document: BenchChem. [Application of 2D NMR for Steroid Structure Elucidation: Application Notes and Protocols]. BenchChem, [2025]. [Online PDF]. Available at: [https://www.benchchem.com/product/b034633#application-of-2d-nmr-for-steroid-structure-elucidation]

Disclaimer & Data Validity:

The information provided in this document is for Research Use Only (RUO) and is strictly not intended for diagnostic or therapeutic procedures. While BenchChem strives to provide accurate protocols, we make no warranties, express or implied, regarding the fitness of this product for every specific experimental setup.

Technical Support: The protocols provided are for reference purposes. Unsure if this reagent suits your experiment? [[Contact our Ph.D. Support Team for a compatibility check](#)]

Need Industrial/Bulk Grade? [Request Custom Synthesis Quote](#)

BenchChem

Our mission is to be the trusted global source of essential and advanced chemicals, empowering scientists and researchers to drive progress in science and industry.

Contact

Address: 3281 E Guasti Rd
Ontario, CA 91761, United States
Phone: (601) 213-4426
Email: info@benchchem.com