

# Application Notes for TG-2-IN-1 in Cell Culture Experiments

**Author:** BenchChem Technical Support Team. **Date:** December 2025

## Compound of Interest

Compound Name: TG-2-IN-1

Cat. No.: B238044

[Get Quote](#)

## Introduction

Transglutaminase 2 (TG2 or TGM2) is a unique and multifunctional enzyme involved in a wide array of cellular processes, including cell adhesion, migration, survival, apoptosis, and extracellular matrix (ECM) organization. TG2's primary enzymatic function is to catalyze the Ca<sup>2+</sup>-dependent cross-linking of proteins by forming stable isopeptide bonds between glutamine and lysine residues. Beyond its cross-linking activity, TG2 also functions as a G-protein in signal transduction and possesses protein disulfide isomerase and protein kinase activities.

Dysregulation of TG2 is implicated in the pathogenesis of numerous diseases, including cancer, neurodegenerative disorders, and fibrosis. In many cancers, elevated TG2 expression is associated with tumor progression, metastasis, and resistance to chemotherapy. This is often mediated through the activation of key survival pathways such as NF- $\kappa$ B, PI3K/Akt, and ERK1/2. Consequently, inhibiting TG2 activity has emerged as a promising therapeutic strategy.

**TG-2-IN-1** is a potent inhibitor of Transglutaminase 2. These application notes provide detailed protocols for utilizing **TG-2-IN-1** in cell culture experiments to investigate the cellular functions of TG2 and to assess its therapeutic potential.

## Product Information and Handling

Parameter	Specification	Reference
Product Name	TG-2-IN-1 (Compound D003)	
Target	Transglutaminase-2 (TGM2)	
Solubility	Soluble in DMSO. For aqueous solutions, prepare a stock in water, then dilute to the working concentration and sterilize with a 0.22 µm filter before use.	
Stability	The compound is reported to be unstable in solutions. It is highly recommended to prepare solutions freshly before each experiment.	
Storage	Store as a solid at -20°C.	

## Experimental Protocols

### Protocol 1: Preparation of TG-2-IN-1 Stock and Working Solutions

Caution: **TG-2-IN-1** is unstable in solution; always prepare fresh for each experiment.

Materials:

- **TG-2-IN-1** powder
- Dimethyl sulfoxide (DMSO), sterile
- Sterile cell culture medium
- Sterile microcentrifuge tubes

Procedure:

- Prepare a 10 mM Stock Solution:
  - Allow the **TG-2-IN-1** vial to equilibrate to room temperature before opening.
  - Add the appropriate volume of DMSO to the vial to create a 10 mM stock solution. For example, for 1 mg of **TG-2-IN-1** with a molecular weight of X g/mol , add Y  $\mu$ L of DMSO. (Note: The exact molecular weight should be obtained from the supplier's data sheet to calculate the precise volume).
  - Vortex thoroughly until the compound is completely dissolved.
- Prepare Working Solutions:
  - Perform serial dilutions of the 10 mM stock solution into sterile cell culture medium to achieve the desired final concentrations for your experiment (e.g., 0.1, 1, 10, 100  $\mu$ M).
  - Ensure the final concentration of DMSO in the culture medium is consistent across all conditions (including the vehicle control) and is typically  $\leq 0.1\%$  to avoid solvent-induced cytotoxicity.
- Application:
  - Add the freshly prepared working solutions to your cell cultures immediately.

## Protocol 2: Cell Viability and Proliferation Assay

This protocol uses a resazurin-based assay (e.g., AlamarBlue or PrestoBlue) to assess the effect of **TG-2-IN-1** on cell viability and proliferation. Metabolically active cells reduce the blue resazurin to the pink, highly fluorescent resorufin.

Materials:

- Cells of interest plated in a 96-well opaque-walled plate
- Complete cell culture medium
- **TG-2-IN-1** working solutions (prepared as in Protocol 1)

- Resazurin-based cell viability reagent
- Phosphate-Buffered Saline (PBS)
- Plate reader capable of measuring fluorescence (Ex/Em ~560/590 nm)

#### Procedure:

- Cell Seeding: Seed cells into a 96-well opaque-walled plate at a predetermined optimal density (e.g., 5,000-10,000 cells/well) in 100  $\mu$ L of complete culture medium. Allow cells to adhere and grow for 24 hours.
- Treatment:
  - Remove the medium and replace it with 100  $\mu$ L of medium containing various concentrations of **TG-2-IN-1** (e.g., 0.1  $\mu$ M to 100  $\mu$ M).
  - Include a "vehicle control" (medium with the same final concentration of DMSO) and an "untreated control" (medium only).
- Incubation: Incubate the plate for the desired experimental duration (e.g., 24, 48, 72 hours, or up to 5 days as used in some studies).
- Assay:
  - Add 20  $\mu$ L of the resazurin reagent to each well.
  - Incubate for 1-4 hours at 37°C, protected from light, until a color change is apparent.
- Measurement: Measure the fluorescence intensity using a plate reader with an excitation wavelength of ~560 nm and an emission wavelength of ~590 nm.
- Data Analysis:
  - Subtract the average fluorescence of the "medium only" blank wells from all other readings.

- Express the results as a percentage of the vehicle control to determine the relative cell viability.

Treatment	Concentration Range	Incubation Time	Expected Outcome
TG-2-IN-1	0.1 - 100 $\mu$ M	24h - 5 days	Dose-dependent decrease in cell viability/proliferation in TG2-dependent cell lines.
Vehicle (DMSO)	$\leq$ 0.1%	24h - 5 days	No significant effect on cell viability compared to untreated control.

### Protocol 3: Western Blot Analysis of TG2-Modulated Signaling (e.g., ERK1/2 Pathway)

This protocol details how to assess changes in protein expression and phosphorylation in a TG2-regulated pathway, such as the ERK1/2 pathway, following treatment with **TG-2-IN-1**.

Materials:

- Cells cultured in 6-well plates
- TG-2-IN-1** working solutions
- RIPA lysis buffer supplemented with protease and phosphatase inhibitors
- BCA Protein Assay Kit
- Laemmli sample buffer (4x)
- SDS-PAGE gels, running buffer, and transfer buffer
- PVDF or nitrocellulose membranes

- Blocking buffer (e.g., 5% non-fat milk or BSA in TBST)
- Primary antibodies (e.g., anti-phospho-ERK1/2, anti-total-ERK1/2, anti-TG2, anti- $\beta$ -actin)
- HRP-conjugated secondary antibody
- Enhanced Chemiluminescence (ECL) substrate

#### Procedure:

- Cell Treatment: Culture cells to 70-80% confluency in 6-well plates. Treat with **TG-2-IN-1** at desired concentrations for the specified time.
- Cell Lysis:
  - Wash cells twice with ice-cold PBS.
  - Add 100-150  $\mu$ L of ice-cold RIPA buffer to each well. Scrape the cells and transfer the lysate to a pre-chilled microcentrifuge tube.
  - Incubate on ice for 30 minutes, vortexing occasionally.
  - Centrifuge at 14,000 x g for 15 minutes at 4°C. Collect the supernatant.
- Protein Quantification: Determine the protein concentration of each lysate using a BCA assay.
- Sample Preparation: Mix 20-30  $\mu$ g of protein from each sample with Laemmli buffer and boil at 95°C for 5 minutes.
- SDS-PAGE and Transfer:
  - Load samples onto an SDS-PAGE gel and separate proteins by electrophoresis.
  - Transfer the separated proteins to a PVDF membrane.
- Immunoblotting:
  - Block the membrane with blocking buffer for 1 hour at room temperature.

- Incubate the membrane with the primary antibody (e.g., anti-phospho-ERK1/2) overnight at 4°C, diluted in blocking buffer according to the manufacturer's recommendation (e.g., 1:1000).
- Wash the membrane three times with TBST for 10 minutes each.
- Incubate with the appropriate HRP-conjugated secondary antibody for 1 hour at room temperature.
- Wash the membrane again as in the previous step.
- Detection: Apply ECL substrate and visualize the protein bands using a chemiluminescence imaging system.
- Stripping and Re-probing: To normalize the data, strip the membrane and re-probe with an antibody for total ERK1/2 and a loading control like  $\beta$ -actin.

## Protocol 4: In Vitro TG2 Transamidation Activity Assay

This assay quantifies the enzymatic activity of TG2 by measuring the incorporation of a primary amine substrate, 5-biotinamidopentylamine (5BP), onto a glutamine-containing protein.

Materials:

- Cell lysates or purified TG2 enzyme
- TG2 Assay Buffer (e.g., 50 mM Tris-HCl, 5 mM CaCl<sub>2</sub>, 1 mM DTT, pH 7.5)
- 5-biotinamidopentylamine (5BP)
- Glutamine-donor substrate (e.g., N,N-dimethylcasein)
- Streptavidin-coated 96-well plates
- Streptavidin-HRP conjugate
- TMB substrate and Stop Solution

Procedure:

- Prepare Lysates/Enzyme: Prepare cell lysates as described in Protocol 3 or use purified TG2 enzyme.
- Coat Plate (if using an immobilized substrate): Coat a high-binding 96-well plate with a glutamine-donor substrate (e.g., 10 µg/mL N,N-dimethylcasein) overnight at 4°C. Wash and block the plate.
- Reaction Setup:
  - In each well, add 50 µL of cell lysate (containing 10-20 µg of protein) or purified TG2.
  - Add **TG-2-IN-1** at various concentrations to the appropriate wells.
  - To initiate the reaction, add 50 µL of a reaction mixture containing TG2 Assay Buffer and 500 µM 5BP.
  - Include a negative control with a Ca<sup>2+</sup> chelator (e.g., 10 mM EDTA) instead of CaCl<sub>2</sub>.
- Incubation: Incubate the plate at 37°C for 1-2 hours.
- Detection:
  - Wash the wells thoroughly with PBS-Tween (0.05%).
  - Add Streptavidin-HRP conjugate (diluted in blocking buffer) and incubate for 1 hour at room temperature.
  - Wash wells again.
  - Add TMB substrate and incubate until a blue color develops.
  - Add Stop Solution and measure the absorbance at 450 nm.
- Data Analysis: Higher absorbance indicates higher TG2 activity. Calculate the percentage of inhibition for **TG-2-IN-1** treated samples relative to the untreated control.



Assay	Key Reagents	Measurement	Expected Outcome with TG-2-IN-1
TG2 Activity	5-biotinamidopentylamine (5BP), N,N-dimethylcasein	Absorbance at 450 nm	Dose-dependent reduction in signal, indicating inhibition of transamidation.

## Visualizations: Pathways and Workflows

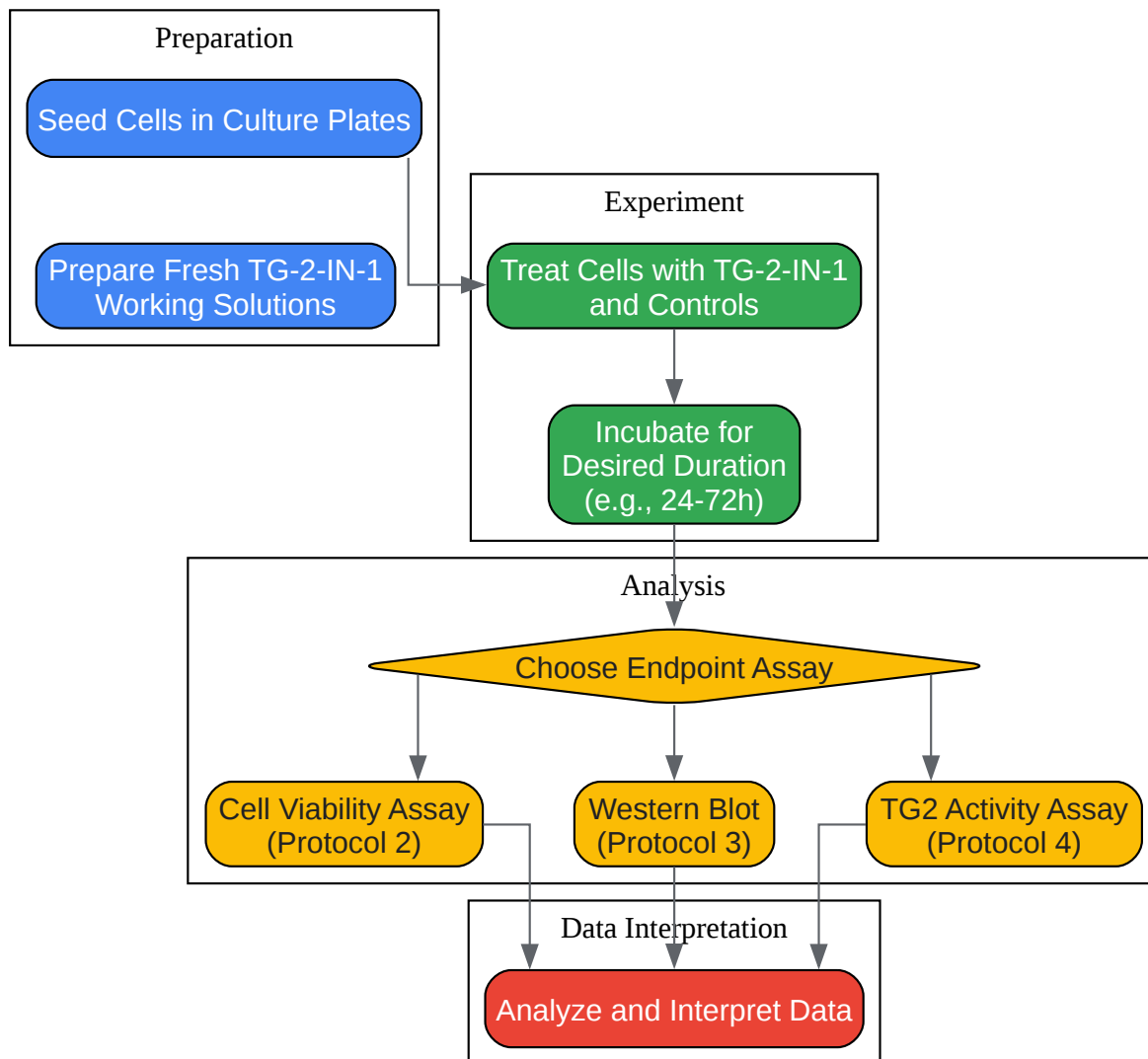

[Click to download full resolution via product page](#)

General experimental workflow for using **TG-2-IN-1**.

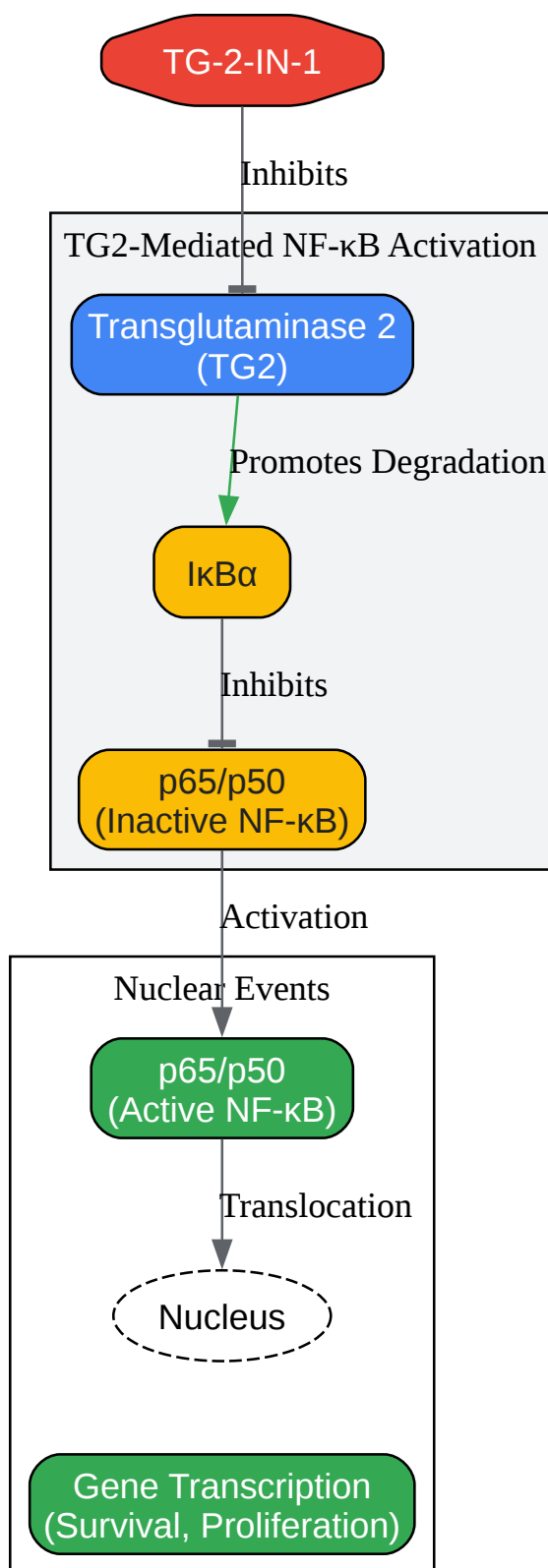

[Click to download full resolution via product page](#)

TG2-mediated non-canonical activation of the NF-κB pathway.

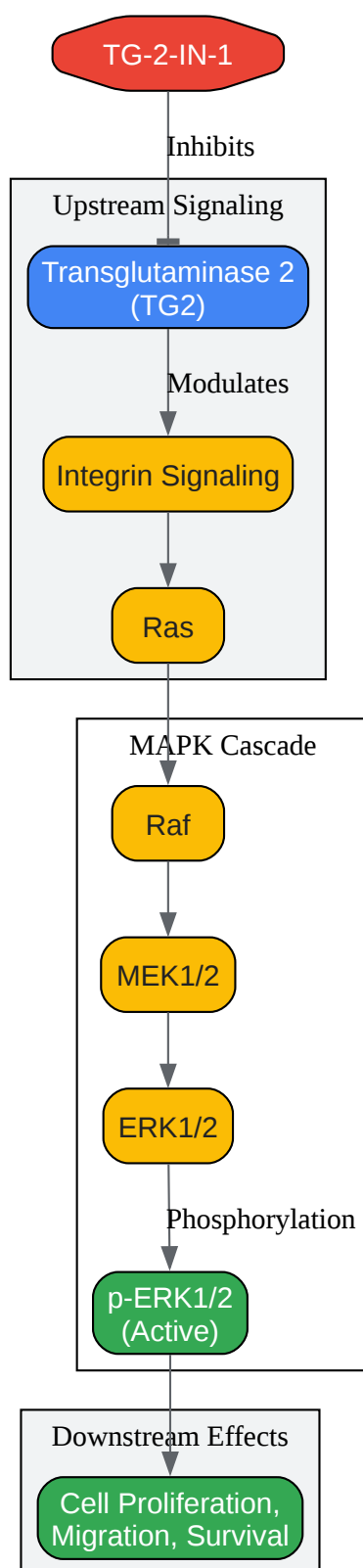

[Click to download full resolution via product page](#)

TG2 involvement in the activation of the ERK1/2 pathway.

- To cite this document: BenchChem. [Application Notes for TG-2-IN-1 in Cell Culture Experiments]. BenchChem, [2025]. [Online PDF]. Available at: [<https://www.benchchem.com/product/b238044#how-to-use-tg-2-in-1-in-cell-culture-experiments>]

---

### Disclaimer & Data Validity:

The information provided in this document is for Research Use Only (RUO) and is strictly not intended for diagnostic or therapeutic procedures. While BenchChem strives to provide accurate protocols, we make no warranties, express or implied, regarding the fitness of this product for every specific experimental setup.

**Technical Support:** The protocols provided are for reference purposes. Unsure if this reagent suits your experiment? [[Contact our Ph.D. Support Team for a compatibility check](#)]

**Need Industrial/Bulk Grade?** [Request Custom Synthesis Quote](#)

## BenchChem

Our mission is to be the trusted global source of essential and advanced chemicals, empowering scientists and researchers to drive progress in science and industry.

### Contact

Address: 3281 E Guasti Rd

Ontario, CA 91761, United States

Phone: (601) 213-4426

Email: [info@benchchem.com](mailto:info@benchchem.com)