

Application Notes and Protocols for the Quantitative Analysis of Acetylalkannin using HPLC

Author: BenchChem Technical Support Team. **Date:** December 2025

Compound of Interest

Compound Name: *Acetylalkannin*

Cat. No.: *B10789796*

[Get Quote](#)

For Researchers, Scientists, and Drug Development Professionals

This document provides a detailed application note and protocol for the quantitative analysis of **Acetylalkannin** using High-Performance Liquid Chromatography (HPLC). **Acetylalkannin**, a significant bioactive naphthoquinone derivative found in various plant species of the Boraginaceae family, such as *Alkanna tinctoria* and *Arnebia euchroma*, has garnered interest for its potential therapeutic properties.[1][2][3] This guide offers a comprehensive methodology for accurate and reproducible quantification, essential for research, quality control, and drug development.

High-Performance Liquid Chromatography (HPLC) Method

This section outlines the instrumental parameters for the quantitative analysis of **Acetylalkannin**. The method is based on reversed-phase chromatography, which is well-suited for the separation of moderately polar compounds like **Acetylalkannin**.

Parameter	Condition
HPLC System	Agilent 1260 Infinity II or equivalent
Column	C18, 4.6 x 250 mm, 5 µm particle size
Mobile Phase	Acetonitrile : Methanol (95:5, v/v), Isocratic
Flow Rate	1.0 mL/min
Column Temperature	25 °C
Injection Volume	10 µL
Detector	UV-Vis Diode Array Detector (DAD)
Detection Wavelength	276 nm
Run Time	Approximately 15 minutes

Experimental Protocols

Standard Solution Preparation

- Primary Stock Solution (1 mg/mL): Accurately weigh 10 mg of **Acetylalkannin** reference standard and dissolve it in 10 mL of methanol in a volumetric flask. Sonicate for 5 minutes to ensure complete dissolution.
- Working Standard Solutions: Prepare a series of working standard solutions by serially diluting the primary stock solution with the mobile phase to obtain concentrations ranging from 1 µg/mL to 100 µg/mL. These will be used to construct the calibration curve.

Sample Preparation (from Plant Root Material)

- Drying and Grinding: Dry the plant root material at 40°C until a constant weight is achieved. Grind the dried roots into a fine powder using a laboratory mill.
- Extraction: Accurately weigh 1 g of the powdered root material into a flask. Add 20 mL of methanol and perform extraction using an ultrasonic bath for 30 minutes at room temperature.

- Filtration: Filter the extract through a 0.45 μm syringe filter into an HPLC vial.
- Dilution: Depending on the expected concentration of **Acetylalkannin**, the filtered extract may need to be diluted with the mobile phase to fall within the linear range of the calibration curve.

Method Validation Summary

The following table summarizes the typical validation parameters for a quantitative HPLC method for **Acetylalkannin**, based on data for the closely related compound acetylshikonin.[4] These parameters should be established during in-house validation.

Validation Parameter	Typical Value
Linearity (R^2)	> 0.999
Limit of Detection (LOD)	~0.06 $\mu\text{g/mL}$
Limit of Quantification (LOQ)	~0.20 $\mu\text{g/mL}$
Precision (%RSD)	< 2%
Accuracy (% Recovery)	95% - 105%

Diagrams

Experimental Workflow

The following diagram illustrates the complete workflow for the quantitative analysis of **Acetylalkannin** from sample preparation to data analysis.

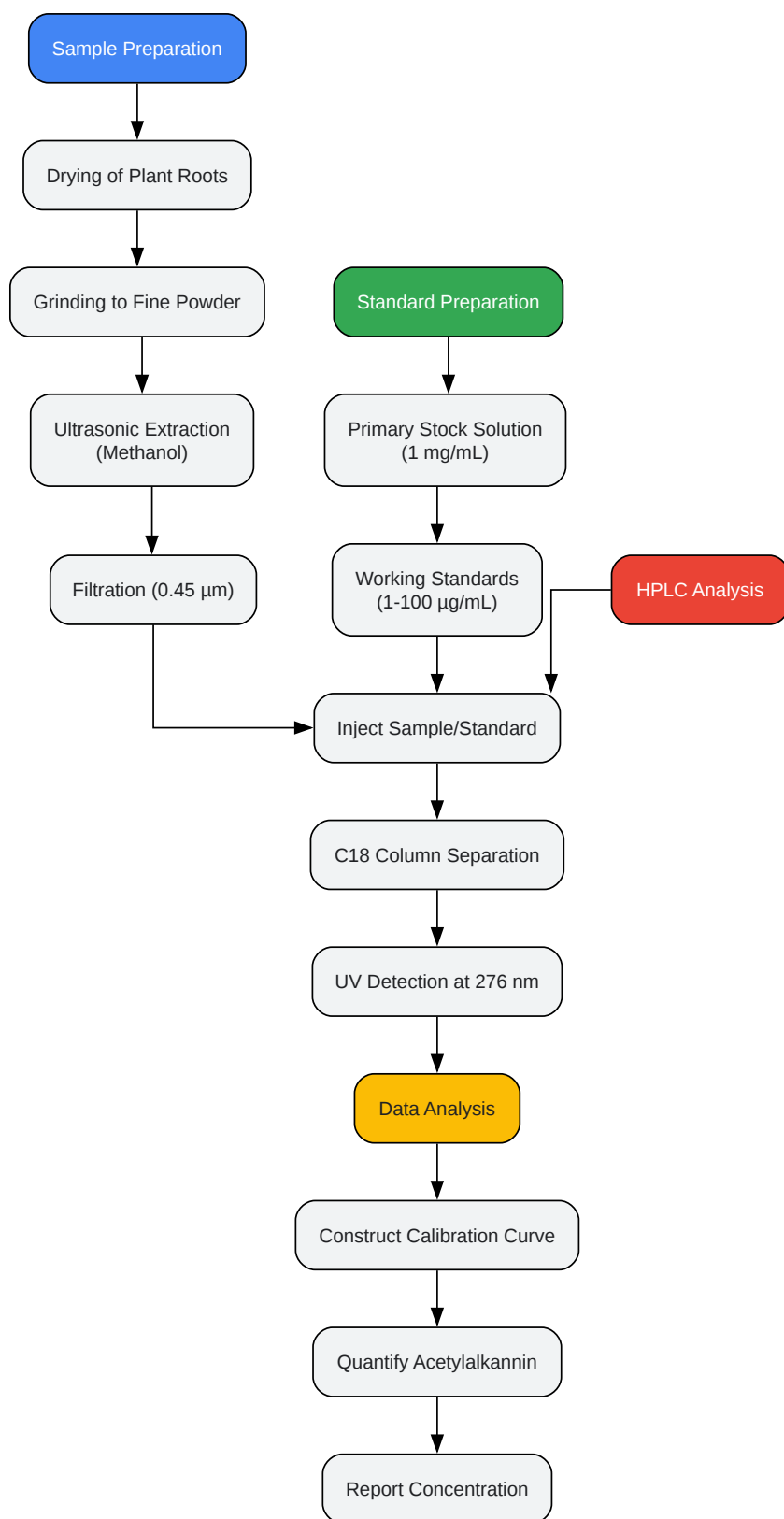

[Click to download full resolution via product page](#)

Caption: Workflow for **Acetylalkannin** Quantification.

Logical Relationship of HPLC Parameters

This diagram shows the logical relationship and influence of different HPLC parameters on the final analytical result.

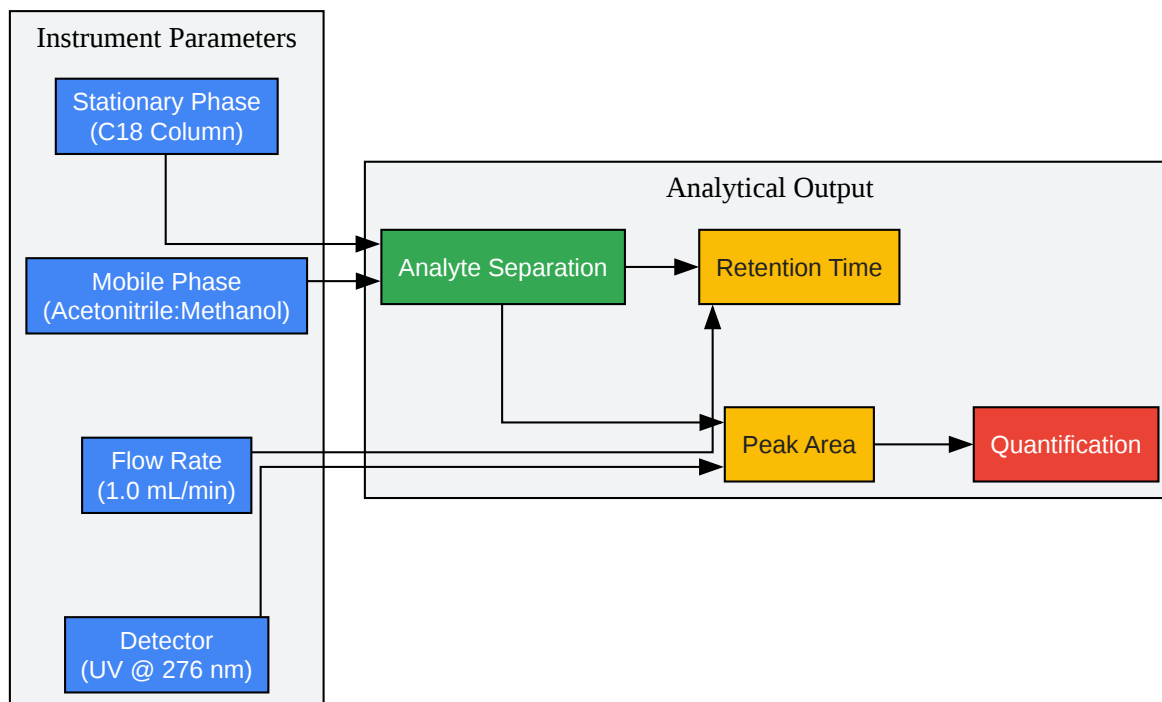

[Click to download full resolution via product page](#)

Caption: HPLC Parameter Interrelationships.

Need Custom Synthesis?

BenchChem offers custom synthesis for rare earth carbides and specific isotopic labeling.

Email: info@benchchem.com or [Request Quote Online](#).

References

- 1. Analysis of alkannin derivatives from *Alkanna* species by high-performance liquid chromatography/photodiode array/mass spectrometry - PubMed [pubmed.ncbi.nlm.nih.gov]
- 2. Pharmacological and analytical aspects of alkannin/shikonin and their derivatives: An update from 2008 to 2022 - PMC [pmc.ncbi.nlm.nih.gov]
- 3. Insights into the mechanism of *Arnebia euchroma* on leukemia via network pharmacology approach - PMC [pmc.ncbi.nlm.nih.gov]
- 4. Isolation and purification of acetylshikonin and beta-acetoxyisovalerylshikonin from cell suspension cultures of *Arnebia euchroma* (Royle) Johnston using rapid preparative HPLC - PubMed [pubmed.ncbi.nlm.nih.gov]
- To cite this document: BenchChem. [Application Notes and Protocols for the Quantitative Analysis of Acetylalkannin using HPLC]. BenchChem, [2025]. [Online PDF]. Available at: [https://www.benchchem.com/product/b10789796#quantitative-analysis-of-acetylalkannin-using-hplc]

Disclaimer & Data Validity:

The information provided in this document is for Research Use Only (RUO) and is strictly not intended for diagnostic or therapeutic procedures. While BenchChem strives to provide accurate protocols, we make no warranties, express or implied, regarding the fitness of this product for every specific experimental setup.

Technical Support: The protocols provided are for reference purposes. Unsure if this reagent suits your experiment? [[Contact our Ph.D. Support Team for a compatibility check](#)]

Need Industrial/Bulk Grade? [Request Custom Synthesis Quote](#)

BenchChem

Our mission is to be the trusted global source of essential and advanced chemicals, empowering scientists and researchers to drive progress in science and industry.

Contact

Address: 3281 E Guasti Rd

Ontario, CA 91761, United States

Phone: (601) 213-4426

Email: info@benchchem.com