

Application Notes and Protocols for the Liquid Chromatography Analysis of Triacontyl Hexacosanoate

Author: BenchChem Technical Support Team. **Date:** December 2025

Compound of Interest

Compound Name: *Triacontyl hexacosanoate*

Cat. No.: *B081258*

[Get Quote](#)

Introduction

Triacontyl hexacosanoate (C₅₆H₁₁₂O₂) is a long-chain wax ester, a class of lipids known for their challenging analytical characteristics due to poor solubility in common organic solvents and lack of strong chromophores for UV detection. This document provides detailed application notes and protocols for the analysis of **triacontyl hexacosanoate** using liquid chromatography (LC) methods, primarily focusing on High-Performance Liquid Chromatography (HPLC) and Liquid Chromatography-Mass Spectrometry (LC-MS). These methods are crucial for researchers, scientists, and drug development professionals working with formulations or natural products containing such long-chain esters.

The protocols provided are based on established methodologies for the analysis of similar long-chain wax esters and are intended to serve as a robust starting point for method development and validation.

I. Recommended Liquid Chromatography Methods

Two primary methods are presented, leveraging different detection techniques: Evaporative Light Scattering Detection (ELSD) and Mass Spectrometry (MS). Reversed-phase chromatography using a C30 column is recommended for optimal separation of these large, nonpolar molecules.[1] Non-aqueous mobile phases are employed to ensure solubility throughout the analysis.[2][3]

Method 1: HPLC with Evaporative Light Scattering Detection (ELSD)

This method is suitable for the quantification of **triacontyl hexacosanoate** without the need for mass spectrometry. ELSD is a universal detection method that is not dependent on the optical properties of the analyte.

Method 2: LC-MS with Atmospheric Pressure Chemical Ionization (APCI)

This method offers higher specificity and sensitivity, allowing for both quantification and structural confirmation of the analyte. APCI is a suitable ionization technique for nonpolar compounds like wax esters.^{[1][2][3]}

II. Data Presentation: Chromatographic Conditions

The following table summarizes the key parameters for the two recommended methods for the analysis of **triacontyl hexacosanoate**.

Parameter	Method 1: HPLC-ELSD	Method 2: LC-APCI-MS
Column	C30 Reversed-Phase, 5 μ m, 4.6 x 250 mm	C30 Reversed-Phase, 3 μ m, 2.1 x 150 mm
Mobile Phase A	Methanol	Methanol
Mobile Phase B	Chloroform	Chloroform
Gradient	0-10 min: 95% A, 5% B 10-40 min: to 50% A, 50% B 40-45 min: to 95% A, 5% B 45-50 min: 95% A, 5% B	0-5 min: 95% A, 5% B 5-25 min: to 50% A, 50% B 25-28 min: to 95% A, 5% B 28-30 min: 95% A, 5% B
Flow Rate	1.0 mL/min	0.4 mL/min
Column Temperature	40°C	45°C
Injection Volume	20 μ L	5 μ L
Detector	ELSD	Mass Spectrometer with APCI source
ELSD Settings	Nebulizer Temp: 40°C, Evaporator Temp: 60°C, Gas Flow: 1.5 L/min	-
APCI-MS Settings	-	Corona Current: 5 μ A Vaporizer Temp: 400°C Capillary Temp: 250°C Scan Mode: Positive Ion, Full Scan (m/z 400-1000)

III. Experimental Protocols

A. Sample Preparation

Due to the low solubility of **triacontyl hexacosanoate**, sample preparation is a critical step.

- Standard Solution Preparation:
 - Accurately weigh 10 mg of **triacontyl hexacosanoate** standard.

- Dissolve in 10 mL of chloroform to prepare a 1 mg/mL stock solution. Gentle heating in a warm water bath (not exceeding 50°C) may be required to aid dissolution.
- Prepare a series of working standards by serial dilution of the stock solution with the initial mobile phase composition (e.g., 95:5 Methanol:Chloroform).
- Sample Preparation:
 - For solid samples, accurately weigh a known amount of the sample.
 - Extract the sample with chloroform, using sonication or gentle heating to ensure complete extraction of the wax esters.
 - Filter the extract through a 0.45 µm PTFE syringe filter to remove any particulate matter.
 - The filtered extract can then be diluted as necessary with the initial mobile phase before injection.

B. HPLC-ELSD Protocol (Method 1)

- Instrument Setup:
 - Install the C30 reversed-phase column (5 µm, 4.6 x 250 mm) in the column oven.
 - Set the column oven temperature to 40°C.
 - Prime the HPLC pumps with the respective mobile phases (A: Methanol, B: Chloroform).
 - Set the ELSD parameters: Nebulizer Temperature at 40°C, Evaporator Temperature at 60°C, and Nitrogen gas flow at 1.5 L/min. Allow the detector to stabilize.
- Chromatographic Run:
 - Set the flow rate to 1.0 mL/min.
 - Program the gradient as specified in the data table.
 - Equilibrate the column with the initial mobile phase composition (95% A, 5% B) for at least 15 minutes or until a stable baseline is achieved.

- Inject 20 μ L of the prepared sample or standard.
- Start the data acquisition.
- Data Analysis:
 - Identify the peak corresponding to **triacontyl hexacosanoate** based on its retention time from the standard injection.
 - Integrate the peak area to quantify the amount of **triacontyl hexacosanoate** in the sample by comparing it to the calibration curve generated from the standards.

C. LC-APCI-MS Protocol (Method 2)

- Instrument Setup:
 - Install the C30 reversed-phase column (3 μ m, 2.1 x 150 mm) in the column oven.
 - Set the column oven temperature to 45°C.
 - Prime the LC pumps with the respective mobile phases (A: Methanol, B: Chloroform).
 - Set up the APCI-MS detector in positive ion mode.
 - Set the APCI source parameters: Corona Current at 5 μ A, Vaporizer Temperature at 400°C, and Capillary Temperature at 250°C.
- Chromatographic Run:
 - Set the flow rate to 0.4 mL/min.
 - Program the gradient as specified in the data table.
 - Equilibrate the column with the initial mobile phase composition (95% A, 5% B) for at least 10 minutes or until a stable baseline and spray are observed in the mass spectrometer.
 - Inject 5 μ L of the prepared sample or standard.
 - Start the data acquisition in full scan mode (m/z 400-1000).

- Data Analysis:
 - Extract the ion chromatogram for the expected protonated molecule of **triacontyl hexacosanoate** ($[M+H]^+$).
 - Identify the peak at the correct retention time and m/z value.
 - For quantification, create a calibration curve by plotting the peak area against the concentration of the standards.

IV. Mandatory Visualizations

Experimental Workflow Diagram

The following diagram illustrates the general workflow for the analysis of **triacontyl hexacosanoate** using liquid chromatography.

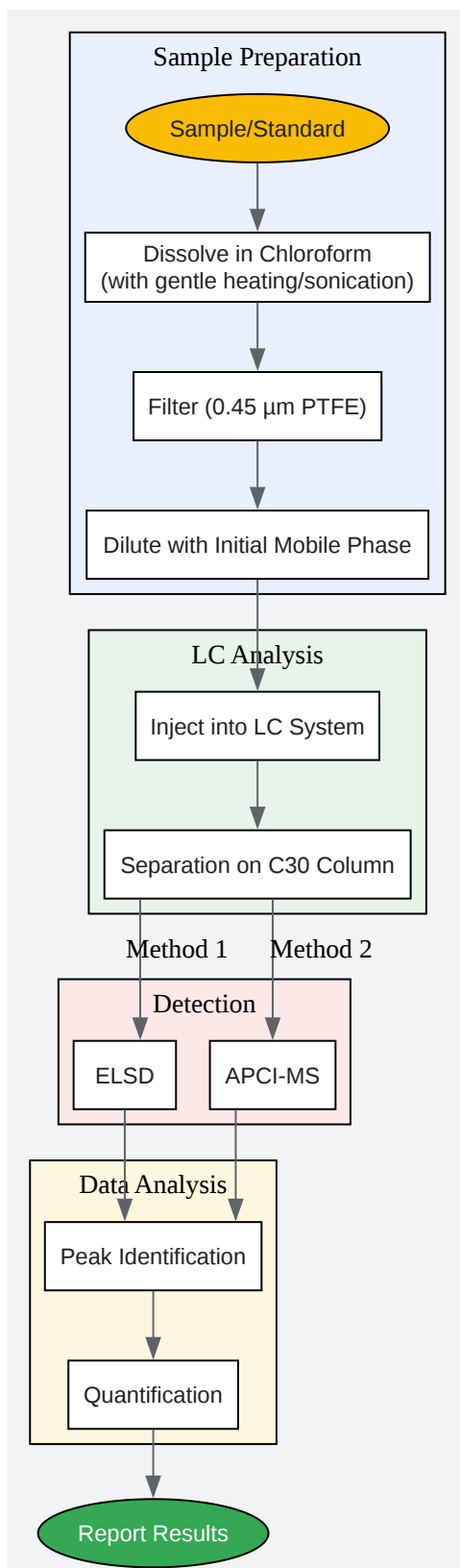

[Click to download full resolution via product page](#)

Need Custom Synthesis?

BenchChem offers custom synthesis for rare earth carbides and specific isotopic labeling.

Email: info@benchchem.com or [Request Quote Online](#).

References

- 1. tandfonline.com [tandfonline.com]
- 2. Analysis of wax ester molecular species by high performance liquid chromatography/atmospheric pressure chemical ionisation mass spectrometry - PubMed [pubmed.ncbi.nlm.nih.gov]
- 3. Analysis of wax ester molecular species by high performance liquid chromatography/atmospheric pressure chemical ionisation mass spectrometry | CoLab [colab.ws]
- To cite this document: BenchChem. [Application Notes and Protocols for the Liquid Chromatography Analysis of Triacetyl Hexacosanoate]. BenchChem, [2025]. [Online PDF]. Available at: [https://www.benchchem.com/product/b081258#liquid-chromatography-methods-for-triacetyl-hexacosanoate]

Disclaimer & Data Validity:

The information provided in this document is for Research Use Only (RUO) and is strictly not intended for diagnostic or therapeutic procedures. While BenchChem strives to provide accurate protocols, we make no warranties, express or implied, regarding the fitness of this product for every specific experimental setup.

Technical Support: The protocols provided are for reference purposes. Unsure if this reagent suits your experiment? [[Contact our Ph.D. Support Team for a compatibility check](#)]

Need Industrial/Bulk Grade? [Request Custom Synthesis Quote](#)

BenchChem

Our mission is to be the trusted global source of essential and advanced chemicals, empowering scientists and researchers to drive progress in science and industry.

Contact

Address: 3281 E Guasti Rd

Ontario, CA 91761, United States

Phone: (601) 213-4426

Email: info@benchchem.com