

Application Notes and Protocols for Utilizing ^{15}N -Glucosamine in Protein NMR Spectroscopy

Author: BenchChem Technical Support Team. **Date:** December 2025

Compound of Interest

Compound Name: *Glucosamine-15N (hydrochloride)*

Cat. No.: *B583474*

[Get Quote](#)

For Researchers, Scientists, and Drug Development Professionals

Introduction

Nuclear Magnetic Resonance (NMR) spectroscopy is a powerful technique for studying protein structure, dynamics, and interactions at an atomic level. Isotopic labeling of proteins with NMR-active nuclei, such as ^{15}N , is often essential for these studies. While uniform ^{15}N labeling using $^{15}\text{NH}_4\text{Cl}$ is a standard method, the specific incorporation of ^{15}N through metabolic precursors like glucosamine offers unique advantages, particularly for the study of glycoproteins and their interactions.

This document provides detailed application notes and protocols for the use of ^{15}N -Glucosamine in NMR spectroscopy of proteins. Glucosamine is a key precursor in the hexosamine biosynthetic pathway (HBP), leading to the formation of UDP-N-acetylglucosamine (UDP-GlcNAc), a fundamental building block for N-linked and O-linked glycosylation of proteins. By providing ^{15}N -labeled glucosamine to cell cultures, the ^{15}N isotope can be specifically incorporated into the glycan moieties of glycoproteins, as well as potentially into the side chains of certain amino acids through metabolic pathways. This targeted labeling approach can simplify complex NMR spectra and provide specific insights into the roles of glycosylation in protein function.

Applications of ^{15}N -Glucosamine Labeling in Protein NMR

- **Studying Glycoprotein Structure and Dynamics:** By specifically labeling the glycan portions of a glycoprotein, NMR can be used to probe the structure, conformation, and dynamics of the carbohydrate chains and their influence on the protein scaffold.
- **Investigating Protein-Ligand Interactions:** ^{15}N -Glucosamine labeling is invaluable for studying the interactions between glycoproteins and their binding partners, such as other proteins, antibodies, or small molecules. Chemical shift perturbation (CSP) mapping of the ^{15}N -labeled glycans can identify the specific sugar residues involved in the interaction.[1]
- **Mapping Glycosylation Sites:** While primarily a tool for structural and dynamic studies, the specific labeling of glycans can aid in confirming the presence and general location of glycosylation sites in conjunction with other techniques like mass spectrometry.
- **Simplifying Complex Spectra:** For large glycoproteins, uniform ^{15}N labeling can result in highly crowded and complex NMR spectra. Specific labeling of the glycan moieties can significantly reduce spectral overlap, facilitating resonance assignment and analysis.

The Hexosamine Biosynthetic Pathway: The Route of ^{15}N Incorporation

The incorporation of the ^{15}N label from glucosamine into glycoproteins is primarily mediated by the Hexosamine Biosynthetic Pathway (HBP). When ^{15}N -glucosamine is supplied to cells, it is taken up and phosphorylated to glucosamine-6-phosphate. Through a series of enzymatic reactions, this is converted to UDP-N-acetyl- ^{15}N -glucosamine (UDP- ^{15}N -GlcNAc). This activated sugar is then used by glycosyltransferases in the endoplasmic reticulum and Golgi apparatus to build the glycan chains on nascent proteins. The nitrogen atom of the acetamido group of GlcNAc is derived from the amino group of glucosamine, thus carrying the ^{15}N label into the glycoprotein.

It is also important to note that the amide side chain of glutamine is a key nitrogen donor in the de novo synthesis of glucosamine-6-phosphate from fructose-6-phosphate. Therefore, providing ^{15}N -labeled glutamine is an alternative and common strategy for labeling the hexosamine pathway.[1]

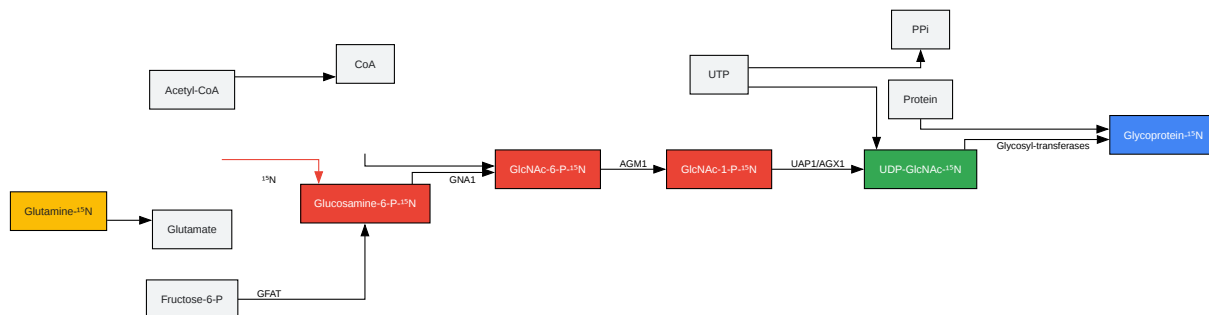

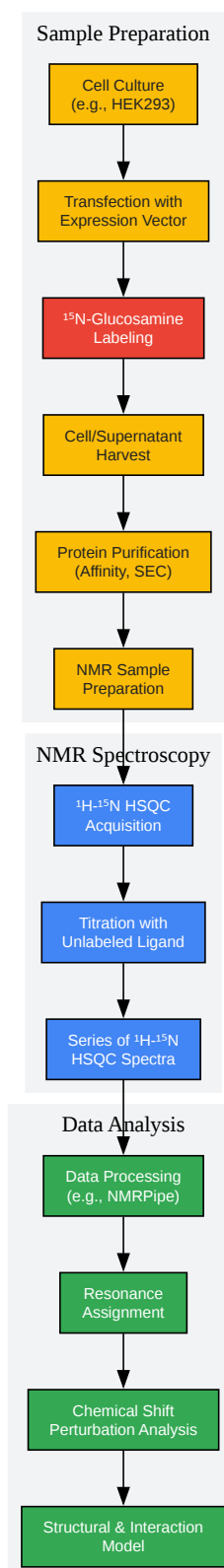

[Click to download full resolution via product page](#)

Need Custom Synthesis?

BenchChem offers custom synthesis for rare earth carbides and specific isotopic labeling.

Email: info@benchchem.com or [Request Quote Online](#).

References

- 1. [mdpi.com](https://www.mdpi.com) [mdpi.com]
- To cite this document: BenchChem. [Application Notes and Protocols for Utilizing ¹⁵N-Glucosamine in Protein NMR Spectroscopy]. BenchChem, [2025]. [Online PDF]. Available at: [<https://www.benchchem.com/product/b583474#using-glucosamine-15n-for-nmr-spectroscopy-of-proteins>]

Disclaimer & Data Validity:

The information provided in this document is for Research Use Only (RUO) and is strictly not intended for diagnostic or therapeutic procedures. While BenchChem strives to provide accurate protocols, we make no warranties, express or implied, regarding the fitness of this product for every specific experimental setup.

Technical Support: The protocols provided are for reference purposes. Unsure if this reagent suits your experiment? [[Contact our Ph.D. Support Team for a compatibility check](#)]

Need Industrial/Bulk Grade? [Request Custom Synthesis Quote](#)

BenchChem

Our mission is to be the trusted global source of essential and advanced chemicals, empowering scientists and researchers to drive progress in science and industry.

Contact

Address: 3281 E Guasti Rd

Ontario, CA 91761, United States

Phone: (601) 213-4426

Email: info@benchchem.com