

Application Notes and Protocols for UNC2025 in Leukemia Cell Lines

Author: BenchChem Technical Support Team. **Date:** December 2025

Compound of Interest

Compound Name: UNC2025

Cat. No.: B612028

[Get Quote](#)

For Researchers, Scientists, and Drug Development Professionals

Abstract

UNC2025 is a potent, orally bioavailable small molecule inhibitor targeting both MERTK and FLT3 tyrosine kinases.[1][2] These kinases are frequently overexpressed or mutated in various hematological malignancies, including acute lymphoblastic leukemia (ALL) and acute myeloid leukemia (AML), making them attractive therapeutic targets.[1] This document provides detailed in vitro protocols for evaluating the efficacy of **UNC2025** in leukemia cell lines, including methods for assessing its impact on cell signaling, apoptosis, cell cycle progression, and clonogenic potential.

Mechanism of Action

UNC2025 functions as a dual inhibitor of MER and FLT3 kinases.[3][4] In leukemia cells expressing these kinases, **UNC2025** has been shown to potently inhibit their phosphorylation and downstream pro-survival signaling pathways.[1][2] Key downstream targets that are inhibited upon **UNC2025** treatment include STAT6, AKT, and ERK1/2.[1] This inhibition of critical signaling cascades leads to the induction of apoptosis, a reduction in cell proliferation, and a decreased ability of leukemia cells to form colonies.[1][2]

Quantitative Data Summary

The following table summarizes the inhibitory concentrations (IC50) of **UNC2025** against its primary targets and in cellular assays.

Target/Assay	Cell Line/System	IC50 Value	Reference
MERTK (enzymatic)	Cell-free assay	0.16 nM (Ki)	[1][2]
FLT3 (enzymatic)	Cell-free assay	~0.8 nM	[3]
MERTK Phosphorylation	697 (B-ALL)	2.7 nM	[4]
FLT3 Phosphorylation	Molm-14 (AML, FLT3-ITD+)	14 nM	[4]
Viable Cell Reduction	Primary Leukemia Patient Samples	Median IC50 of 2.38 μ M	[3]

Experimental Protocols

Herein are detailed protocols for key in vitro experiments to characterize the effects of **UNC2025** on leukemia cell lines.

Western Blot Analysis of MERTK/FLT3 Phosphorylation

This protocol is designed to assess the inhibition of MERTK and FLT3 phosphorylation in leukemia cell lines following **UNC2025** treatment.

Materials:

- Leukemia cell lines (e.g., 697 for MERTK, Molm-14 for FLT3-ITD)
- **UNC2025** (stock solution in DMSO)
- Cell culture medium
- Pervanadate (phosphatase inhibitor)
- Cell lysis buffer (e.g., RIPA buffer with protease and phosphatase inhibitors)

- Protein A/G agarose beads
- Primary antibodies (anti-MERTK, anti-phospho-MERTK, anti-FLT3, anti-phospho-FLT3)
- Secondary antibody (HRP-conjugated)
- SDS-PAGE gels and blotting equipment
- Chemiluminescent substrate

Procedure:

- Seed leukemia cells at a density of 3×10^6 cells/mL and culture overnight.
- Treat cells with varying concentrations of **UNC2025** (e.g., 0-300 nM) or DMSO vehicle control for 1 hour.[2][4]
- To stabilize phosphorylated proteins, add pervanadate to the cell cultures for the final 3 minutes of incubation.[2][4]
- Harvest cells by centrifugation and wash once with cold PBS.
- Lyse the cell pellet with ice-cold lysis buffer.
- Clarify the lysate by centrifugation and collect the supernatant.
- For immunoprecipitation, incubate the lysate with the primary antibody against the total protein (MERTK or FLT3) overnight at 4°C with gentle rocking.[5]
- Add Protein A/G agarose beads and incubate for another 1-3 hours at 4°C.[5]
- Wash the beads several times with lysis buffer.
- Elute the protein by boiling the beads in SDS sample buffer.
- Separate the proteins by SDS-PAGE and transfer to a PVDF membrane.
- Probe the membrane with primary antibodies against the phosphorylated and total forms of the target protein.

- Incubate with an appropriate HRP-conjugated secondary antibody.
- Visualize the protein bands using a chemiluminescent substrate and an imaging system.

Apoptosis Assay by Annexin V/PI Staining

This flow cytometry-based assay quantifies the induction of apoptosis and necrosis in leukemia cells treated with **UNC2025**.

Materials:

- Leukemia cell lines
- **UNC2025**
- Annexin V-FITC/PE
- Propidium Iodide (PI)
- 1X Annexin V Binding Buffer (10 mM Hepes, pH 7.4, 140 mM NaCl, 2.5 mM CaCl₂)
- Flow cytometer

Procedure:

- Seed cells at a density of $0.5-1 \times 10^6$ cells/mL in a suitable culture vessel.
- Treat cells with desired concentrations of **UNC2025** or DMSO vehicle for 24-48 hours.
- Harvest both adherent and suspension cells and wash twice with cold PBS by centrifugation (e.g., 500 x g for 5 minutes).[\[6\]](#)
- Resuspend the cell pellet in 1X Annexin V Binding Buffer.
- Add Annexin V-FITC/PE and PI to the cell suspension.
- Incubate for 15-20 minutes at room temperature in the dark.
- Add additional 1X Annexin V Binding Buffer to each sample.

- Analyze the samples by flow cytometry within one hour.
 - Healthy cells: Annexin V-negative and PI-negative.
 - Early apoptotic cells: Annexin V-positive and PI-negative.
 - Late apoptotic/necrotic cells: Annexin V-positive and PI-positive.

Cell Cycle Analysis by Propidium Iodide Staining

This protocol allows for the analysis of cell cycle distribution in leukemia cells following **UNC2025** treatment.

Materials:

- Leukemia cell lines
- **UNC2025**
- Cold 70% ethanol
- PBS
- Propidium Iodide (PI) staining solution (containing RNase A)
- Flow cytometer

Procedure:

- Seed and treat cells with **UNC2025** as described for the apoptosis assay.
- Harvest cells and wash with PBS.
- Fix the cells by dropwise addition of cold 70% ethanol while vortexing, then incubate on ice for at least 30 minutes.[7]
- Wash the fixed cells with PBS.
- Resuspend the cell pellet in PI staining solution containing RNase A to degrade RNA.[8]

- Incubate for 15-30 minutes at room temperature in the dark.
- Analyze the samples by flow cytometry. The DNA content will distinguish cells in G0/G1, S, and G2/M phases of the cell cycle.

Colony Formation Assay

This assay assesses the effect of **UNC2025** on the anchorage-independent growth and self-renewal capacity of leukemia cells. The method differs slightly for AML and ALL cell lines.

For AML Cell Lines (e.g., Molm-14) - Soft Agar Assay:

Materials:

- AML cell line
- **UNC2025**
- Complete cell culture medium
- Agarose (DNA grade)
- 6-well plates

Procedure:

- Prepare a base layer of 0.5-0.6% agarose in complete medium in each well of a 6-well plate and allow it to solidify.[9]
- Prepare a cell suspension in complete medium.
- Mix the cell suspension with 0.3-0.4% agarose in complete medium containing the desired concentration of **UNC2025** or DMSO vehicle.
- Carefully layer this cell-agarose mixture on top of the base layer.
- Incubate the plates at 37°C in a humidified incubator for 10-21 days, refreshing the medium with **UNC2025** or vehicle control twice a week.[4]

- Stain the colonies with a solution like crystal violet or MTT and count them using a microscope.[10]

For ALL Cell Lines (e.g., 697) - Methylcellulose Assay:

Materials:

- ALL cell line
- **UNC2025**
- Methylcellulose-based medium (e.g., MethoCult™)
- Complete cell culture medium
- 35 mm culture dishes

Procedure:

- Treat ALL cells with **UNC2025** or DMSO vehicle for 48 hours in liquid culture.
- Count the viable cells and resuspend them in complete medium.
- Mix the cell suspension with the methylcellulose medium.
- Dispense the mixture into 35 mm culture dishes.
- Incubate at 37°C in a humidified incubator for 10-14 days.[11][12]
- Count the colonies using an inverted microscope.

Visualizations

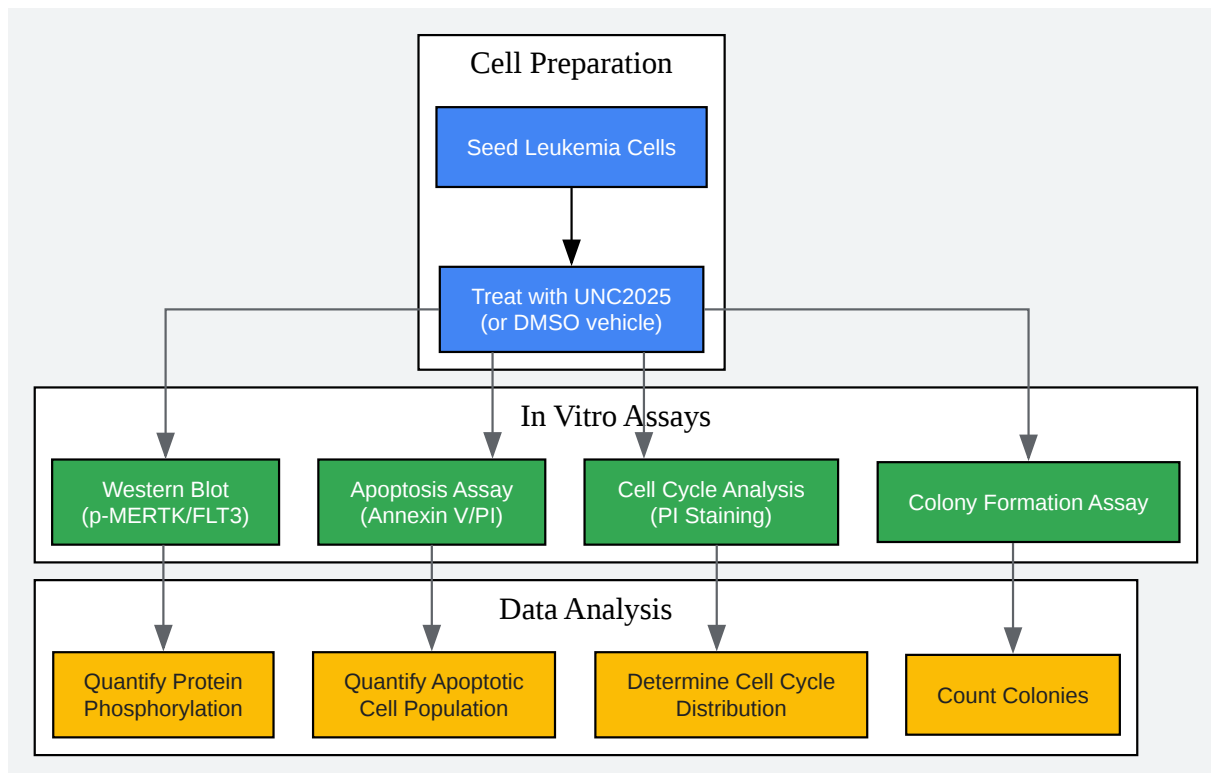

[Click to download full resolution via product page](#)

Caption: Experimental workflow for **UNC2025** in vitro studies.

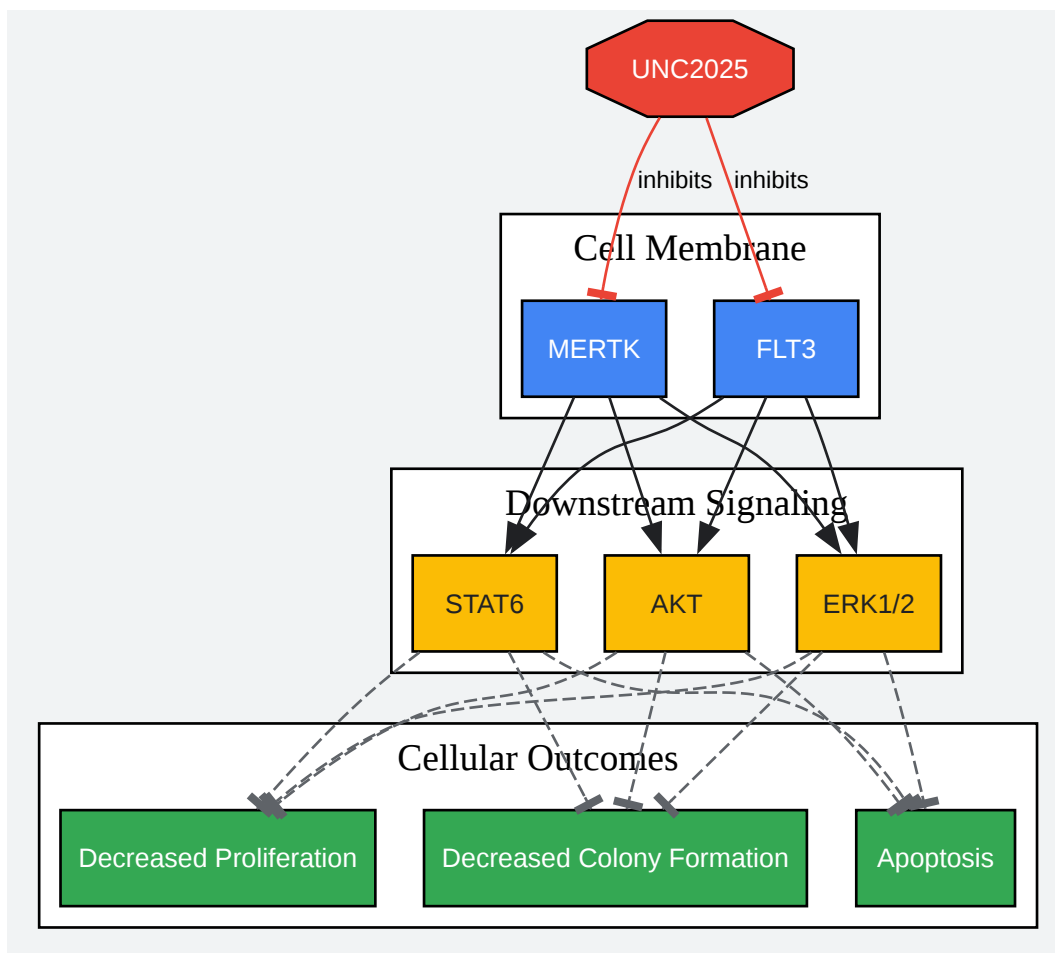

[Click to download full resolution via product page](#)

Caption: **UNC2025** signaling pathway inhibition in leukemia.

Need Custom Synthesis?

BenchChem offers custom synthesis for rare earth carbides and specific isotopic labeling.

Email: info@benchchem.com or [Request Quote Online](#).

References

- 1. UNC2025, a MERTK small molecule inhibitor, is therapeutically effective alone and in combination with methotrexate in leukemia models - PMC [pmc.ncbi.nlm.nih.gov]
- 2. aacrjournals.org [aacrjournals.org]
- 3. medchemexpress.com [medchemexpress.com]

- 4. pubs.acs.org [pubs.acs.org]
- 5. ulab360.com [ulab360.com]
- 6. Protocol for Apoptosis Assay by Flow Cytometry Using Annexin V Staining Method - PMC [pubmed.ncbi.nlm.nih.gov]
- 7. bio-rad-antibodies.com [bio-rad-antibodies.com]
- 8. ucl.ac.uk [ucl.ac.uk]
- 9. Colony formation in soft agar [bio-protocol.org]
- 10. SOFT AGAR ASSAY FOR COLONY FORMATION [www2.lbl.gov]
- 11. Colony Forming Cell (CFC) Assay for Human Hematopoietic Cells - PMC [pubmed.ncbi.nlm.nih.gov]
- 12. 4.6. Colony-Forming Cell (CFC) Assay [bio-protocol.org]
- To cite this document: BenchChem. [Application Notes and Protocols for UNC2025 in Leukemia Cell Lines]. BenchChem, [2025]. [Online PDF]. Available at: [<https://www.benchchem.com/product/b612028#unc2025-in-vitro-protocol-for-leukemia-cell-lines>]

Disclaimer & Data Validity:

The information provided in this document is for Research Use Only (RUO) and is strictly not intended for diagnostic or therapeutic procedures. While BenchChem strives to provide accurate protocols, we make no warranties, express or implied, regarding the fitness of this product for every specific experimental setup.

Technical Support: The protocols provided are for reference purposes. Unsure if this reagent suits your experiment? [[Contact our Ph.D. Support Team for a compatibility check](#)]

Need Industrial/Bulk Grade? [Request Custom Synthesis Quote](#)

BenchChem

Our mission is to be the trusted global source of essential and advanced chemicals, empowering scientists and researchers to drive progress in science and industry.

Contact

Address: 3281 E Guasti Rd

Ontario, CA 91761, United States

Phone: (601) 213-4426

Email: info@benchchem.com